



Provided by the author(s) and NUI Galway in accordance with publisher policies. Please cite the published version when available.

Title	Detection and repair of flash-eye in handheld devices
Author(s)	Corcoran, Peter; Bigioi, Petronel; Nanu, Florin
Publication Date	2014
Publication Information	Corcoran, P. M., Bigioi, P., & Nanu, F. (2014, 10-13 Jan. 2014). Detection and repair of flash-eye in handheld devices. Paper presented at the 2014 IEEE International Conference on Consumer Electronics (ICCE).
Publisher	IEEE
Link to publisher's version	http://ieeexplore.ieee.org/xpl/articleDetails.jsp?arnumber=6775978
Item record	http://hdl.handle.net/10379/5577
DOI	http://dx.doi.org/10.1109/ICCE.2014.6775978

Downloaded 2018-11-14T09:31:58Z

Some rights reserved. For more information, please see the item record link above.



Detection & Repair of Flash-Eye Defects on Handheld Devices

Peter M. Corcoran¹, *Fellow, IEEE*, Petronel Bigioi^{1,2}, *Senior Member, IEEE*, Florin Nanu³.

¹National University of Ireland Galway; ²DigitalOptics Corp., Galway, ³Digital Optics Corp., Romania
peter.corcoran@nuigalway.ie, pbigioi@doc.com, fnanu@doc.com

Abstract-- Red-eye and flash-eye defects in still photography continue to cause problems for digital imaging devices. New variants of flash-eye defects have appeared as cameras and cameras sub-systems get smaller in size. This paper reviews a range of the more recent techniques that have been applied to solve various problems associated with red and non-red flash-eye, particularly solutions which are implemented in cameras or mobile imaging devices. Four principle categories of flash-eye defect are identified and techniques are outlined to deal with each of these. The use of face, eye and scene metadata obtained within the camera is also considered. Some advanced techniques to improve the correction and reconstruction of eye regions are also considered.

I. INTRODUCTION

In an earlier overview of redevye techniques Gasparini and Schettini [1] have outlined and discussed the principle algorithms employed for red-eye detection and correction in digital imaging. However the work of these authors was mainly focused on the solution of the red-eye problem through static analysis of a digital image *after an imaging device has acquired it*. Their emphasis is on algorithmic improvements or more sophisticated pattern analysis techniques but does not take account of, or show how to exploit aspects of the image acquisition itself.

In this article we review a range of more recent techniques employed to detect and correct flash-eye defects. More specifically, techniques that are implemented in a digital camera or handheld imaging device, to improve the detection of such flash defects, are examined. In addition, classes of non-red or part-red (hybrid) defects have become more common in recent years due to the miniaturization of digital imaging systems. To our knowledge the techniques described here are the first to address such 'non-red' defects. A more detailed review of recent 'flash-eye' patents is given in [2]

This article is divided as follows. Firstly we introduce a simple, yet efficient algorithm [3], [4] in *Section II*. This differs from much of the prior art described in [1] as it directly detects red-eye candidate regions without relying on an explicit face or eye detection process. In *Section 3* we take a look inside the camera and consider the problem of red-eye detection from the perspective of an embedded imaging device. This demonstrates that the existing prior art was too focused on the optimization of pattern recognition and ignored many practical aspects of the digital camera that acquires the image. *Section 4* considers the use of more than one image to improve the accuracy of red-eye detection, introducing the concept of flash/no-flash photography and *two-stage* detection. *Section 8* discusses non-red flash artifacts in some details. While in practice less than 10% of flash artifacts fall into this category, it is these artifacts that cannot be detected

by conventional algorithms.

Section 9 discusses the role of face and eye tracking in the detection and correction of flash defects. Again we focus on the implications of adapting these techniques for use in an embedded imaging device such as a digital camera. *Section 10* tackles some issues relating to the correction of defects, in particular non-red defects. Finally, in *Section 11* some conclusions on the state of red-eye correction in digital cameras are provided and some emerging challenges for the next generation of consumer imaging devices are introduced.

II. COLOR SPACES AND FOUNDATION ALGORITHM

On first consideration the problem to find and fix red-eye defects appears relatively trivial - we are looking for red, round patches of pixels located within a larger region of skin pixels. A very useful description of a simple yet efficient algorithm is given in [3], [4]. A key consideration is the speed and simplicity of the initial segmentation. Implementing the segmentation in Lab color space optimizes the segmentation, but no production consumer devices provide Lab color channels. As a consequence it is necessary to use look-up tables to achieve segmentation on YCC or RGB color images. This is best achieved using a hardware pre-processing architecture that can threshold individual pixels [5]. Further details can be found in [2]

III. INSIDE THE CAMERA

A. Simple Uses of Camera Metadata

Metadata is information about a digital image, beyond the image itself. The most important metadata available within a camera is knowledge of whether or not the flash was applied when an image was acquired. The exposure settings are also significant because a flash used in bright daylight is very unlikely to generate a flash artifact simply because the subjects eyes are already adapted to the bright daylight.

B. The Image Processing Pipeline

A typical acquisition pipeline is shown in Figure 5 below. The image sensor typically has a number of parameter settings that may be adjusted by the main camera CPU, typically by writing to a static memory within the image sensor itself. Access to this parameter block is usually by serial bus such as I2C and it enables control of exposure timings and gains for different pixel blocks within the sensor array. Raw image pixels from the sensor are clocked through an image signal processor (ISP), dedicated to real-time processing of acquired images. This ISP may be a DSP, GPU or a specialized core of a multi-CPU SoC. Typically it performs a range of key

acquisition functions including de-Bayering and determining white balance and tone management for the imaged scene.

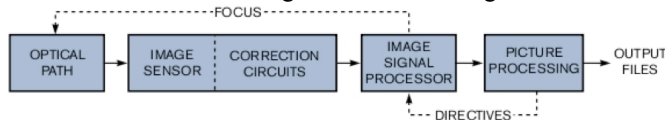

Figure 1: Main functional blocks of the Image Processing Pipeline (IPP) in a digital imaging device.

Some camera manufacturers have a custom architecture for the ISP. Finally the image, processed by the ISP arrives at the main CPU for high level processing, including the implementation of specialized filters such as red-eye.

C. Using Subsample Images for Detection

As image sizes increased significantly over the past decade simple algorithms such as those of Section II became less reliable. The detailed texture of a high-resolution eye-region combined with variations in noise would lead to segmentation failing on larger eye-regions. Fortunately most cameras provide a down-sampled image stream that is used to provide a real-time preview of the scene imaged by the lens. This *preview stream* can also be available for pre-processing and allows red-eye algorithms to operate on a smaller, subsample version of the main acquired image. This refinement has allowed in-camera algorithms to compensate for challenges created by growing image sizes.

IV. USING MULTIPLE IMAGES - TWO STAGE DETECTION

One major advantage that comes from operating an image-processing filter within a digital camera is the ability to obtain a second view onto a scene. From the perspective of red-eye detection this leads to a number of important refinement that can be particularly powerful when executed within the imaging device.

A. Flash and No-Flash Images

Flash/No-Flash techniques were first proposed by Baron [6], [7] and appear to offer an ideal technique to locate flash-eye defects in a digital image. Like many inventions the idea is simple and involves capturing a first image without flash illumination, followed immediately by a second image with flash illumination. A more extensive discussion on the use of flash/no-flash techniques for digital imaging is provided by Petschnigg *et al* [8]. In practice it is difficult to align the two images accurately, and there are challenges in blending differently exposed images, particularly in low-light scenarios.

B. Two Stage Detection

As mentioned in Section III-C a preview image stream that can be processed independently from the main still image acquisition is available in most imaging subsystems. This enables a new family of red-eye algorithms where an initial, speed-optimized, analysis is applied to one or more preview images, followed by a slower and more thorough analysis applied to the main acquired image. Corrections from the speed-optimized analysis may be used to display a corrected image on the device, but the final archival image and red-eye

candidates are determined from the main acquired image.

C. Using a Face Detector/Tracker

Many cameras now incorporate a face tracking solution either in the applications software, or better integrated into the ISP [9]. Typically faces are tracked in the preview stream, but some processing may occur in the applications processor, thus information about the location of a face may not be available when a flash image is acquired. However a face-tracker will have information about the predicted location of a face - typically a region of the image that is somewhat larger than a face region, but still much smaller than the full imaged scene.

Thus it is possible to restrict where flash-eye detection is applied to a relatively small portion of the image. This become very important as we introduce the concept of non-red and hybrid flash-eye defects.

V. HYBRID & NON-RED DEFECTS

Much of the early literature assumed that red-eye artifacts are substantially red. In fact this is not the case and to a researcher working with flash-eye defects it very quickly becomes apparent that a significant percentage of flash-eye defects exhibit very little red hue. The situation is further complicated by racial differences, particularly between Asian and Caucasian subjects. The latter exhibit darker shades of red and are more susceptible to yellowish artifacts with a bright white central region.

A. Categories of Flash-Eye Defect

There are 4 principle categories of defect. Three of these arise due to the relative positions of lens and flash on a camera. The closer the flash is located to the lens then the more susceptible a camera is to flash-eye. The latest smartphones tend to have the flash located in the same sub-assembly as the miniaturized lens assembly and are even more susceptible than small consumer cameras.

Most defects are standard "red-eye", the color arising from blood vessels in the eyeball. For Caucasian subjects almost 95% of artifacts are red. For Asians this can be as low as 70%.

A second major category is that of golden-eye artifacts, characterized by a yellowish color, with a brighter white region. These occur when the blind spot of the eye is directly aligned with the flash. The third major category of artifact is that of hybrid artifacts exhibiting part-red, part-yellow coloration. These occur at eye-gaze angles close to the blind-spot but not quite aligned with it. Figure 2 below gives a summary of these three categories.



Figure 2(a): Example Golden-eye artifact on the left; Red-eye on right.

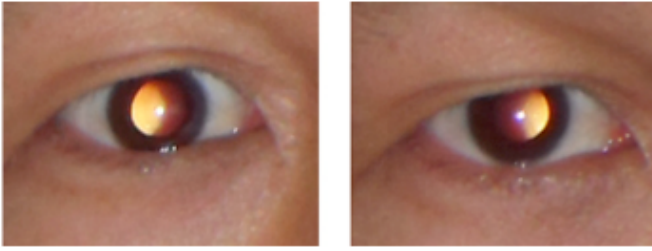

Figure 2(b): Example Hybrid (half-red/half-yellow) artifacts.

A fourth category of artifact occurs when the face is more distant but still within range of the flash. In these cases there is no color evident and the eye region appears white, or off-white in color. As the eye-size is smaller such artifacts impart a eerie appearance and are sometimes described as 'zombie eyes'.

B. Detecting Non-Red Flash Artifacts

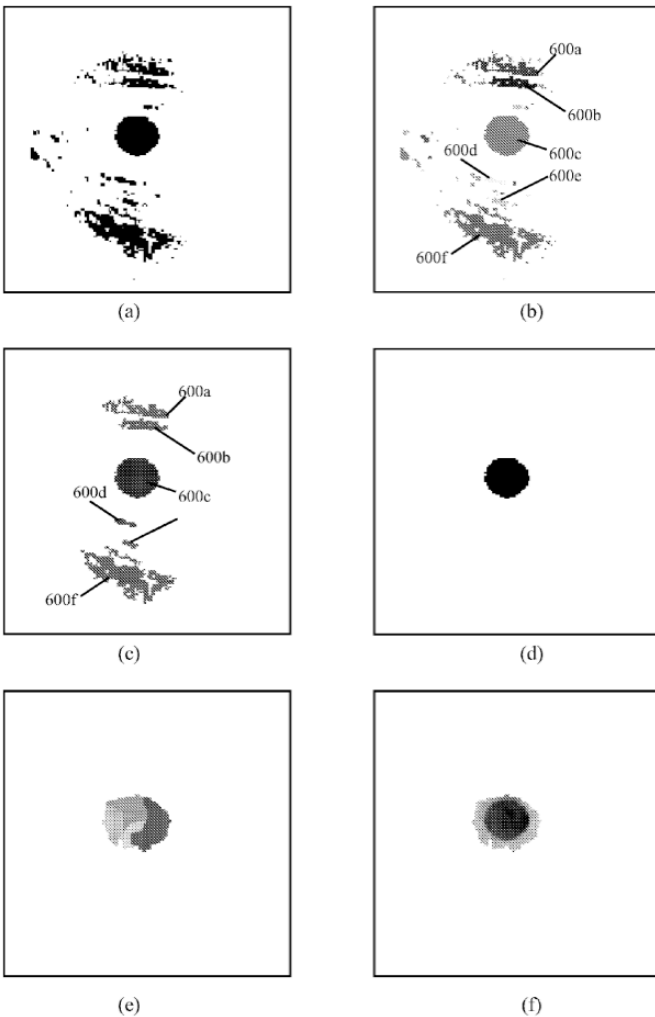

Figure 3: Algorithm to detect & correct Golden-eyes from [10].

1) Golden Eye Artifacts

The various steps of the algorithm are represented in *Figure 3* and match the following steps:

- (a) Threshold the intensity image with a first intensity level;
- (b)&(c) Segment connected components of the thresholded image, into respective groups with a local maximum;
- (d) Eliminate components whose size is outside limits;

(e) Rank the remaining components with respect to average intensity and retain only the top 3-5.

(f) Identify segments in the mean-shift segmented image whose maxima are located inside the selected defect region.

One important aspect of this technique is that a *glint*, or bright spot is generally present in an eye region and for a realistic correction of a flash defect it is desirable to locate and preserve this feature. This may require repeating steps (e) & (f) with different thresholds to determine the glint area. When compared with speed-optimized red-eye algorithms this technique is an order of magnitude slower so it is highly desirable to restrict the area of the image to which it is applied.

2) Hybrid Eye Artifacts

This category of defect is a relatively new form of flash artifact and only occurs on modern consumer cameras with co-located flash and lens assemblies. If the flash is more than c.20mm from the lens then such artifacts will not occur. However, they have become increasing common due to miniaturization of cameras and thus solutions to detection and correction of such defects is needed.

There are two key problems: (i) because these defects are typically half-red/half-yellow they will fail the initial detection tests on roundness and elongation for a simple red-eye algorithm; (ii) for white/golden pixels of a half red-half white/golden eye defect, the L and possibly b characteristics of the pixel may also be either saturated and/or distorted; thus unlike red-eye defects, some of the original image color information is lost and thus correction of the white/golden portion of the defect involves reconstructing the eye, as opposed to the easier restoration process for a conventional red eye defect.

Bearing these differences in mind in Ciuc presents an algorithm to handle such hybrid artifacts [11].

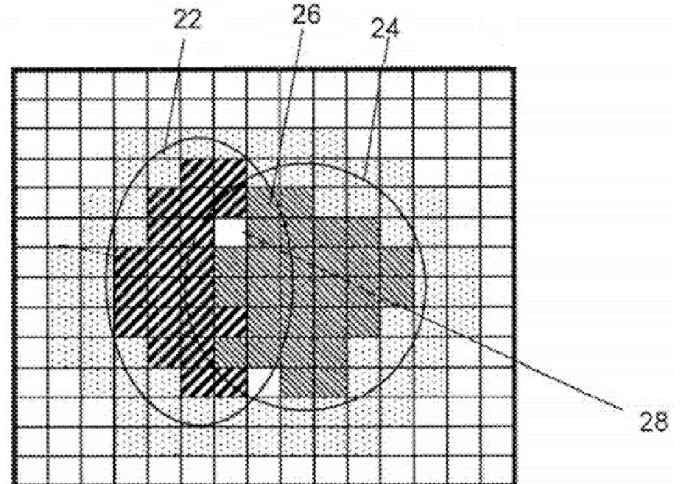

Figure 4: Overlapping regions of a hybrid flash-eye artifact; 22 - red region; 24 - yellow region; 26 - overlap region; 28 - eye-glint; the 'red' region is determined from the first stage of a two-step detector - suitable rejected regions are saved and act as seeds for the 2nd stage search algorithms.

C. Search Strategies - Eye Pairing

Combining this last algorithm with the earlier techniques provides a comprehensive set of tools to analyze and detect

flash-eye defects in an imaging device. However the workflow and modes of use of these techniques will typically be decided by the capabilities of the camera in which they are to be incorporated.

However one case that is more generic is based on the fact that non-red artifacts typically occur in a pair with a conventional red-eye artifact. Thus, after a basic red-eye algorithm is applied to find all standard flash defects it is likely that a face detection result will also be available and this will enable a determination of faces which have a paired set of red-eye, and those which have a single, unpaired, red-eye. By applying a more inclusive filter, or using a non-red algorithm it is practical to determine "missing" eye artifacts [68]. This is especially the case as the areas of the image that must be scanned are very significantly reduced. A simple flowchart is provided in *Figure 5* below.

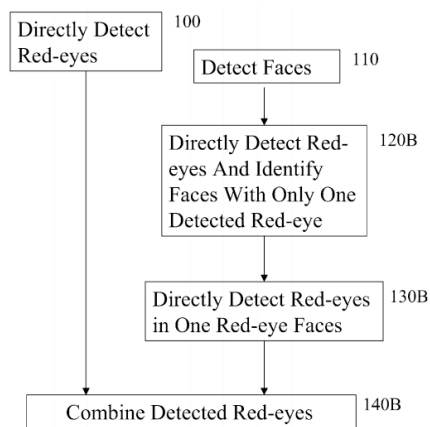

Figure 5: Eye-pair technique to optimize the workflow tasks [68].

VI. THE ROLE OF FACE & EYE TRACKING

Most approaches use some form of skin color or contrast based cross-check of the surrounding pixels to verify that a flash artifact is situated within an area of skin - such cross-checks are much easier to implement and less demanding on resources than a full face detection. Next generation face detection algorithms will be implemented directly as hardware subsystems, but despite increased computational speed the location of confirmed face regions will still not be available until after the completion of the image acquisition process. Thus for practical embodiments it is desirable to use tracking technologies that predict the location of high-priority regions by analyzing multiple preview frames of a video or image sequence.

A. Using a Real-Time Face Tracker

A face tracker is somewhat different from a face detector as it operates on successive frames of a video sequence. One particular aspect of a tracking algorithm is that it predicts where a current set of confirmed faces will appear in the next video frame. These predicted regions are of variable size and are determined from a range of variables, but are typically no more than 40%-50% larger than the face region itself in most circumstances. More importantly these predicted face candidate regions are available at the start of the next image

acquisition sequence.

A speed optimized red-eye filter can operate on the *predicted* face candidate regions of an image provided by a real-time face tracker module. As the face tracker will typically operate on the preview stream these *predicted* face candidate regions are determined for the next preview image frame. An optimized red-eye detector can thus be applied selectively to face regions where it is expected that a red-eye defect will be found - a limited area within the candidate face region. This approach is especially beneficial when it is necessary to apply a more resource-intensive detector such as the non-red or hybrid detectors described in *Section V*.

B. Using a half-face Detector

Another problem that arises in detecting flash-eye defects is a lack of symmetry. Often a face is partly occluded, or two different eye defects may appear in the same face - *Figure 2* is a classic example. One novel approach to deal with unpaired, or differently paired defects is to use a half-face detector [12]. Now as was already explained any 'face detector' is too slow to be useful on a single image frame, but if it is integrated with a full face tracking solution it can predict face locations (or half-faces!) in the next frame.

In addition to confirming eye-pairs using detected *full-faces* it is now also possible to confirm single-eyes using detected *half-faces*. This ensures that we avoid rejecting single-eye flash defects where they occur in partial face regions. It also may suggest additional half-face regions of the image which should have a more thorough analysis applied to ensure that a difficult to detect eye-defect has not been overlooked.

REFERENCES

- [1] F. Gasparini and R. Schettini, "A review of redevye detection and removal in digital images through patents," *Recent Patents Electr. Eng.*, vol. 2, no. 1, pp. 45–53, 2009.
- [2] P. Corcoran and P. Bigioi, "Advances in the detection & repair of flash-eye defects in digital images-a review of recent patents," 2012.
- [3] P. Corcoran, P. Bigioi, E. Steinberg, and A. Pososin, "Automated in-camera detection of flash-eye defects," *IEEE Trans. Consum. Electron.*, vol. 51, no. 1, pp. 11–17, Feb. 2005.
- [4] E. Steinberg, "Method and apparatus for the automatic real-time detection and correction of red-eye defects in batches of digital images or in handheld appliances," 6,873,7432005.
- [5] C. Zaharia, P. Bigioi, and P. Corcoran, "Hybrid video-frame pre-processing architecture for HD-video," *IEEE Int. Conf. Consum. Electron. Electron. (ICCE)*, 2011.
- [6] J. M. Baron, "Method and apparatus for the removal of flash artifacts," 6,859,56522-Feb-2005.
- [7] J. M. Baron, "Method and apparatus for the removal of flash artifacts," 7,027,66211-Apr-2006.
- [8] G. Petschnigg, R. Szeliski, M. Agrawala, M. Cohen, H. Hoppe, and K. Toyama, "Digital photography with flash and no-flash image pairs," *ACM Trans. Graph.*, vol. 23, no. 3, p. 664, Aug. 2004.
- [9] P. Bigioi, C. Zaharia, and P. Corcoran, "Advanced hardware real time face detector," *IEEE Int. Conf. Consum. Electron. Electron. (ICCE)*, 2012.
- [10] M. Ciuc, "Detecting redevye defects in digital images," US 829026716-Oct-2012.
- [11] A. CAPATA, F. NANU, P. CORCORAN, M. CIUC, and E. STEINBERG, "Method and Apparatus of Correcting Hybrid Flash Artifacts in Digital Images," 7,865,03624-May-2007.
- [12] P. M. Corcoran, P. Bigioi, and F. Nanu, "Half-face detector for enhanced performance of flash-eye filter," in *2013 IEEE International Conference on Consumer Electronics (ICCE)*, 2013, pp. 252–253.