



Provided by the author(s) and University of Galway in accordance with publisher policies. Please cite the published version when available.

Title	Chemical Amendment of Dairy Slurry For The Control of Phosphorus in Runoff From Grassland
Author(s)	Brennan, Raymond B.
Publication Date	2011-09-28
Item record	http://hdl.handle.net/10379/2670

Downloaded 2024-04-20T11:33:41Z

Some rights reserved. For more information, please see the item record link above.



NATIONAL UNIVERSITY OF IRELAND GALWAY

**CHEMICAL AMENDMENT OF DAIRY CATTLE
SLURRY FOR THE CONTROL OF PHOSPHORUS
IN RUNOFF FROM GRASSLAND**

Raymond B. Brennan, B.E.

Research Supervisors:

Dr. Mark G. Healy, Civil Engineering NUI Galway

Dr. Owen Fenton, Teagasc, Johnstown Castle, Wexford

Professor of Civil Engineering: Padraic E. O'Donoghue

Thesis submitted in fulfilment of the requirements for the degree of Doctor of
Philosophy.

September 2011

The National University of Ireland requires the signatures of all persons using or photocopying this thesis. Please sign below, and give the address and date.

I would like to dedicate this work to my wonderful family, and to the memory of Eileen
Armstrong, Helena Brennan and baby Helena Brennan.

‘Don't let your success determine your attitude, let your attitude determine your success.’

(Adapted from Ken Brown)

ABSTRACT

Phosphorus (P) loss from grassland to a waterbody can adversely affect water quality. Land application of dairy cattle slurry can result in incidental P losses to runoff in addition to increased chronic P losses from soil as a result of a build-up in Soil Test P (STP). A literature review identified chemical amendment of dairy cattle slurry as a possible mitigation measure to prevent such losses. This study comprised laboratory and field-scale experiments, which investigated the effectiveness and feasibility of chemical amendments in reducing P solubility, taking into account for the first time their pollution swapping potential.

First, a controlled agitator experiment was designed to identify the most effective chemical amendment to reduce Dissolved Reactive Phosphorus (DRP) release to water overlying grassed soil cores, which received un-amended and amended dairy cattle slurry. In addition to effectiveness, the feasibility of these amendments was determined based on several criteria: estimated cost of amendment, amendment delivery to farm, addition of amendment to slurry, and slurry spreading costs due to any volume increases. The four best amendments based on effectiveness and feasibility, at optimum application rates were: ferric chloride (FeCl_2), which reduced the DRP in overlying water by 88%, aluminium chloride (AlCl_3) (87%), alum (83%) and lime (81%). These amendments were then added to slurry immediately before it was surface applied to grassed soil in runoff boxes, which were subjected to simulated rainfall events. Analysis of overland flow showed that PAC (Poly-Aluminium Chloride, a commercially available form of AlCl_3) was the most effective amendment for decreasing DRP losses in runoff following slurry application, while alum proved to be the most effective for total P (TP) and particulate P (PP) reduction. The incidental loss of metals (aluminium (Al), calcium (Ca) and iron (Fe)) in runoff during all experiments was below the maximum allowable concentrations (MAC) for receiving waters.

Once the effectiveness of the amendments under laboratory conditions were quantified, their 'pollution swapping' potential was examined. A laboratory-scale gas chamber experiment was conducted to examine emissions of ammonia (NH_3), nitrous oxide (N_2O),

methane (CH₄) and carbon dioxide (CO₂). After considering pollution swapping in conjunction with amendment effectiveness, the amendments recommended for a micro plot study were, from best to worst: PAC, alum and lime. This component of the study investigated how soil and chemically amended slurry interactions affect amendment effectiveness under field conditions. The results of this micro-plot study validated the results from the laboratory-scale studies. Alum and PAC reduced average flow-weighted mean concentration (FWMC) and total loads of DRP, dissolved un-reactive phosphorus (DUP), PP and TP in runoff, while amendment of slurry with lime at the rate examined in this study was not effective at reducing P losses. Alum amendment significantly increased average FWMC of ammonium-N (NH₄-N) in runoff water during the first rainfall event after the slurry was applied (an 84% increase). This indicates that chemical amendment of dairy cattle slurry conducted on a large scale could increase soluble N losses. Finally, a 9-month incubation experiment was conducted using five Irish grassland soils to examine the effect of amendments on the long-term plant availability of P in soil and the effect of soil type on the stability of reductions in P solubility. The study showed that, with the exception of FeCl₂, the chemical amendments reduced water extractable phosphorus (WEP) without affecting STP.

This study showed that amendments are effective and that there is no major risk of pollution swapping associated with alum and PAC. This is a significant finding as there is now potential to use amendments strategically, in combination with existing POM (programme of measures), to mitigate P losses. The next step will be to examine the use of chemical amendments at catchment-scale. It is hoped that there will be economic incentives given to farmers to reduce nutrient losses. It is possible that P mitigating methods, such as chemical amendment of dairy cattle slurry, may be used strategically within a catchment to bind P in cow and pig slurries.

DECLARATION

This dissertation is the result of my own work, except where explicit reference is made to the work of others, and has not been submitted for another qualification to this or any other university.

Raymond Brennan

ACKNOWLEDGEMENTS

I wish to thank An tOllamh Padraic O'Donoghue for his encouragement and help during the research study and during the preparation of this thesis.

I am grateful to Teagasc for providing a Walsh fellowship and funding for this project, and to the authorities in the National University of Ireland, Galway for providing the facilities to carry out the research work. I would like to express my gratitude to my NUI, Galway supervisor, Dr. Mark Healy and my Teagasc supervisor, Dr. Owen Fenton, who were always encouraging, patient and generous with their time. It has been a wonderful experience working with them and I owe them my deepest gratitude.

I have been very fortunate and received help from many people along the way. I would however like to express a special thanks to Drs. Gary Lanigan and Jim Grant for their time and patience. This work would not have been possible without tremendous cooperation and help from many people, in particular technical staff in Johnstown Castle, Teagasc in Athenry and NUI Galway. A special thanks to Ana Serrenho, Kathy Carney, Maja Drapiewska, Mary O'Brien, Peter Fahy, Gerry Hynes, Aoife Keady, Liwen Xiao, Eoghan Clifford, Denis Brennan, Stan Lalor, Theresa Cowman, Linda Finn, Paddy Sills, Pat Donnelly, Paddy Hayes and Maria Radford. I would also like to extend a special thanks to John Regan for setting up the rainfall simulator and for training me in the lab. I wish to thank my fellow post-grads for their support and time. I also wish to thank the tag rugby team, past and present, for giving me something to look forward to all summer. I have enjoyed my time in NUI Galway immensely and I will always hold my memories of my time in university close to my heart. I wish to thank my friends for their support and patience, especially Joe McGovern for managing to live with me through most of the PhD. I would also to thank my girlfriend, Joanne, for being so kind, encouraging and understanding. Finally, I would like to thank my wonderful father, Michael, and my brothers, Michael, Kieran, Bernard, Dermot and Shane, for their support and endless encouragement throughout this process.

ABBREVIATIONS

<i>a</i>	A constant related to the binding strength of molecules onto the amendments
AD	Anaerobic digestion
Al	Aluminium
AlCl ₃	Aluminium chloride
Al ₂ O ₃	Aluminium oxide
Alum	aluminium sulphate (analytical grade (Al ₂ (SO ₄) ₃ nH ₂ O) and commercial grade)
Al-WTR-1	Al-WTR-alum-based water treatment residual which was dried and crushed to pass 2 mm sieve
Al-WTR-2	Al-WTR-alum-based water treatment residual in sludge form
AOD	Above ordnance datum
APHA	American Public Health Association
AVC	Ammonia volatilisation chamber
<i>b</i>	The theoretical amount of P adsorbed to form a complete monolayer on the surface
bgl	Below ground level
BOD ₅	Five day biological oxygen demand
BS	British Standards
C	The final P concentration of the solution in isotherm test
Ca	Calcium
CaCO ₃	Calcium carbonate
CaCl ₂	Calcium chloride
Ca(OH) ₂	Lime
CC	Container capacity approximate field capacity in incubation experiment
C _e	The concentration of P in solution at equilibrium (mg L ⁻¹)
CH ₄	Methane
CO ₂	Carbon dioxide

CSA	Critical source areas
CSO	Central Statistics Office
CWs	Constructed wetlands
DAFF	Department of Agriculture, Fisheries and Food
d	Day
DM	Dry matter
DRP	Dissolved reactive phosphorus
DUP	Dissolved un-reactive phosphorus
EC	Electrical conductivity
EEC	European Economic Community
EPA	Environment Protection Agency
EPC ₀	Equilibrium P concentration (i.e. the point where no net desorption or sorption occurs) in Langmuir Isotherm
EU	European Union
Fe	Iron
FeCl ₂	Ferrous chloride
FeCl ₃	Ferric chloride
FeSO ₄	Ferric chloride
FGD	Flue gas desulphurization
FWMC	Flow-weighted mean concentration
FWS	Free water surface
GHG	Green house gas
GWP	Global warming potential
H	Hour
ha	Hectare
H ₂	Hydrogen gas
H ₂ S	Hydrogen sulphide
H ₂ SO ₄	Sulphuric acid
HCl	Hydrochloric acid
ICP	Inductive coupled plasma
IPCC	Intergovernmental Panel on Climate Change

K	Potassium
k_d	The slope of the relationship between S' and C
LOI	Loss on ignition
M3	Mehlich-III P
MAC	Max allowable concentration
Mg	Magnesium
MgCl ₂	Magnesium chloride
N	Nitrogen
mo	Month
N ₂	Nitrogen gas
N ₂ O	Nitrous oxide
NH ₃	Ammonia
NH ₄	Ammonium
NH ₄	Ammonium ion
NH ₄ -N	Ammonium nitrogen
NO ₂	Nitrite
NO ₂ -N	Nitrite nitrogen
NO ₃	Nitrate
NO ₃ -N	Nitrate nitrogen
OJEC	Official Journal of the European Community
OM	Organic matter
P	Phosphorus
PAA	Photo-acoustic-analyser
PAC	Poly-aluminium chloride
PAM	Polyacrylamide
PDS	Particle size distribution
POM	Programme of measurements
PP	Particulate phosphorus
PSM	Phosphorus sorbing material
R ²	Regression coefficient
RS1	Rainfall simulation event 1

RS2	Rainfall simulation event 2
RS3	Rainfall simulation event 3
rpm	Revolutions per minute
S'	The mass of P adsorbed from slurry (mg kg^{-1}),
S ₀	The amount of P originally sorbed to the amendment (mg L^{-1})
SAS	Statistical Analysis Software
SI	Statutory Instrument
SS	Suspended sediment
STP	Soil test phosphorus
T _{0.5}	The time for half of ammonia losses to occur
TAN	Total ammonical nitrogen
TDP	Total dissolved phosphorus in water
TDS	Total dissolved solids
TK	Total potassium
TN	Total nitrogen
TON	Total oxidized nitrogen
TP	Total phosphorus
TR	Time from commencement of simulated rainfall event and start of runoff
UK	United Nations
UN	United Nations
U.S.A.	United States of America
USDA	United States Department of Agriculture
USEPA	United States Environment Protection Agency
WEP	Water extractable phosphorus
WFD	Water Framework Directive
WTR	Water treatment residuals
x/m	The mass of P adsorbed per unit mass of amendments (g kg^{-1}) at C _e
Ω	Stream power of overland flow

TABLE OF CONTENTS

ABBREVIATIONS	IX
LIST OF FIGURES	XVIII
LIST OF TABLES	XXIII

CHAPTER 1	INTRODUCTION	1
1.1.	OVERVIEW.....	1
1.2.	PROCEDURE.....	3
1.3.	STRUCTURE OF DISSERTATION	4
CHAPTER 2	LITERATURE REVIEW	6
2.1.	OVERVIEW.....	6
2.2.	AGRICULTURE IN IRELAND.....	6
2.3.	LEGISLATION AND COMPLIANCE	8
2.4.	CURRENT WATER QUALITY STATUS IN IRELAND	8
2.5.	IMPACT OF AGRICULTURE ON WATER QUALITY	10
2.6.	NUTRIENTS LOSS AND PATHWAYS DURING LAND APPLICATION OF DAIRY SLURRY	11
2.7.	PHOSPHORUS.....	11
2.7.1.	Phosphorus in soil.....	12
2.7.2.	Methods used to determine risk of P loss to water	12
2.8.	NITROGEN	16
2.9.	LOSS OF SOLUBLE AND PARTICULATE NUTRIENTS IN RUNOFF.....	19
2.9.1.	Soluble nutrient loss.....	19
2.9.2.	Particulate nutrient loss.....	20
2.10.	GASEOUS EMISSIONS AND THE IMPORTANCE OF CONSIDERING POLLUTION SWAPPING WHEN SELECTING A P MITIGATION MEASURE	24
2.11.	PRESENT AND EMERGING P MITIGATION MEASURES.....	24
2.11.1.	Constructed wetlands	25
2.11.2.	Anaerobic digestion.....	27
2.11.3.	Biochar	29
2.11.4.	Buffer strips and enhanced buffer strips.....	30
2.11.5.	Composting	31
2.11.6.	In-stream and edge of field filters	32
2.11.7.	Sand and woodchip filter systems.....	35

2.11.8.	Slurry separation.....	35
2.11.9.	Use of P sorbing amendments	37
2.11.9.1.	<i>Amendments applied directly to soil</i>	37
2.11.9.2.	<i>Amendments to slurry</i>	38
2.12.	RECOMMENDATIONS AND KNOWLEDGE GAPS	40
CHAPTER 3	EVALUATION OF CHEMICAL AMENDMENTS TO CONTROL PHOSPHORUS LOSSES FROM DAIRY SLURRY	42
3.1.	OVERVIEW.....	42
3.2.	INTRODUCTION.....	42
3.3.	MATERIALS AND METHODS.....	43
3.3.1.	Soil preparation and analysis	43
3.3.2.	Slurry sampling and analysis	45
3.3.3.	PSM sourcing and analysis	45
3.3.4.	Agitator test.....	46
3.3.5.	Water sampling and analysis	50
3.3.6.	Statistical Analysis.....	50
3.3.7.	Cost analysis	50
3.4.	RESULTS	51
3.4.1.	Results of agitator test.....	51
3.4.2.	Cost and feasibility analysis.....	53
3.5.	DISCUSSION	56
3.6.	CONCLUSIONS	58
3.7.	SUMMARY.....	58
CHAPTER 4	LABORATORY-SCALE RAINFALL SIMULATION EXPERIMENT 59	
4.1.	OVERVIEW.....	59
4.2.	INTRODUCTION.....	59
4.3.	MATERIALS AND METHODS.....	60
4.3.1.	Soil sample collection and analysis	60
4.3.2.	Slurry collection and analysis	60
4.3.3.	Slurry amendment and runoff set-up	61
4.3.4.	Sample handling and analysis.....	67
4.3.5.	Statistical analysis.....	67
4.4.	RESULTS	68
4.4.1.	Slurry and amended slurry analysis	68
4.4.2.	Water quality analysis.....	69
4.4.3.	Metals in runoff water.....	73
4.5.	DISCUSSION	76

4.5.1.	Slurry and amended slurry analysis	76
4.5.2.	Water quality	77
4.5.3.	Metals in runoff water	79
4.6.	CONCLUSIONS	80
4.7.	SUMMARY	81
CHAPTER 5	EFFECT OF CHEMICAL AMENDMENT OF DAIRY CATTLE SLURRY ON GREENHOUSE GAS AND AMMONIA EMISSIONS	82
5.1.	OVERVIEW	82
5.2.	INTRODUCTION	82
5.3.	MATERIALS AND METHODS	83
5.3.1.	Soil sample collection and analysis	83
5.3.2.	Dairy slurry collection and analysis	84
5.3.3.	Chemical amendment of slurry	84
5.3.4.	Measurement of ammonia	85
5.3.5.	Measurement of CH ₄ , N ₂ O and CO ₂	87
5.3.6.	Statistical analysis	87
5.4.	RESULTS	88
5.4.1.	Slurry and amended slurry results	88
5.4.2.	Ammonia	89
5.4.3.	Nitrous oxide	91
5.4.4.	Carbon dioxide	91
5.4.5.	Methane emissions	94
5.4.6.	Impact of amendments on global warming potential	95
5.5.	DISCUSSION	97
5.5.1.	Ammonia emissions	97
5.5.2.	Nitrous oxide	99
5.5.3.	Carbon emissions	100
5.5.4.	Impacts of pollution swapping	101
5.6.	CONCLUSIONS	102
5.7.	SUMMARY	103
CHAPTER 6	PLOT-SCALE RAINFALL SIMULATION STUDY	104
6.1.	OVERVIEW	104
6.2.	INTRODUCTION	104
6.3.	MATERIALS AND METHODS	105
6.3.1.	Study site	105
6.3.2.	Slurry analysis	107
6.3.3.	Treatments	109
6.3.4.	Rainfall simulation	110
6.3.5.	Statistical analysis	113

6.4.	RESULTS	114
6.4.1.	Phosphorus (FWMC of DRP, DUP, PP and TP)	114
6.4.2.	Nitrogen	116
6.4.3.	Time to runoff, soil volumetric water content and runoff volume .	117
6.5.	DISCUSSION	119
6.5.1.	Phosphorus (FWMC of DRP, DUP, PP and TP)	119
6.5.2.	Nitrogen	120
6.5.3.	Rainfall intensity, soil volumetric water content, time to runoff and runoff volume.....	121
6.5.4.	Outlook for future implementation of chemical amendment of dairy cattle slurry as a management practice for high P soils	122
6.6.	CONCLUSIONS	124
6.7.	SUMMARY	124
CHAPTER 7	THE LONG-TERM IMPACT OF THE ADDITION OF CHEMICALLY AMENDED DAIRY SLURRY ON PHOSPHORUS CONTENT AND PH OF FIVE SOIL TYPES.....	125
7.1.	OVERVIEW.....	125
7.2.	INTRODUCTION.....	125
7.3.	MATERIALS AND METHODS.....	126
7.3.1.	Soil collection and analysis.....	126
7.3.2.	Slurry collection and analysis	126
7.3.3.	Incubation experiment	128
7.3.4.	Statistical analysis.....	131
7.4.	RESULTS	132
7.4.1.	Water extractable phosphorus.....	132
7.4.2.	Soil test phosphorus	133
7.4.3.	Soil pH	134
7.5.	DISCUSSION	134
7.5.1.	WEP	134
7.5.2.	Soil test phosphorus	139
7.5.3.	Soil pH	139
7.6.	CONCLUSIONS	140
7.7.	SUMMARY.....	140
CHAPTER 8	CONCLUSIONS AND RECOMMENDATIONS	141
8.1.	OVERVIEW.....	141
8.2.	CONCLUSIONS	141
8.3.	RECOMMENDATIONS FOR FUTURE WORK	143
8.4.	CONTEXT.....	144

REFERENCES.....	146
APPENDIX.....	171
<i>APPENDIX A LIST OF PUBLICATIONS.....</i>	<i>172</i>
<i>APPENDIX B RESULTS OF AGITATOR TEST.....</i>	<i>174</i>
<i>APPENDIX C RUNOFF BOX STUDY RESULTS.....</i>	<i>194</i>
<i>APPENDIX D RESULTS FROM CHAPTER 5</i>	<i>212</i>
<i>APPENDIX E PHOTOGRAPHS OF SLURRY AND AMENDED SLURRY APPLIED TO PLOTS (CHAPTER 6).....</i>	<i>238</i>
<i>APPENDIX F RESULTS OF PLOT STUDY.....</i>	<i>240</i>
<i>APPENDIX G INCUBATION STUDY RESULTS</i>	<i>259</i>

LIST OF FIGURES

FIGURE 2.1 NUMBER OF GROUND WATER MONITORING SITES WITH PHOSPHATE CONCENTRATIONS FROM 1995 TO 2009 (MCGARRIGLE ET AL., 2011).....	9
FIGURE 2.2 NUMBER OF REPORTED FISH KILLS ATTRIBUTED TO AGRICULTURE, INDUSTRY, LOCAL AUTHORITY, OTHER AND UNKNOWN SOURCES (MCGARRIGLE ET AL., 2011).....	10
FIGURE 2.3 THE SOIL P CYCLE: ITS COMPONENTS AND MEASURABLE FRACTIONS (STEWARD AND SHARPLEY, 1987).....	13
FIGURE 2.4 SCHEMATIC OF THE SOIL N CYCLE (KETTERINGS ET AL., 2011)	17
FIGURE 2.5 RELATIONSHIP BETWEEN THE AMMONIA/AMMONIUM ($\text{NH}_3/\text{NH}_4^+$) RATIO AND PH (GAY AND KNOWLTON, 2005).....	18
FIGURE 2.6 DETACHMENT OF SOIL PARTICLES IN A RAINFALL EVENT (ROSE, 2004).....	21
FIGURE 2.7 RATE OF SEDIMENT DEPOSITION IN SURFACE RUNOFF (ROSE, 2004).....	22
FIGURE 2.8 ENTRAINMENT AND RE-ENTRAINMENT OF SEDIMENT (ROSE, 2004).....	23
FIGURE 2.9 COMPOST FILLED SOCKS IN INSTRUMENTED DRAINAGE CHANNEL (SHIPITALO ET AL., 2010A).....	33
FIGURE 2.10 PERMEABLE EDGE OF FIELD BARRIERS (O'CONNOR ET AL., 2010).....	34
FIGURE 2.11 SCHEMATIC AND PHOTO OF FERRIC-SULPHATE DOSER IN OPERATION IN JOKIOINEN, FINLAND (NARVANEN ET AL., 2008).....	35
FIGURE 2.12 PILOT SCALE WOOD CHIP FILTER USED TO TREAT THE LIQUID PORTION OF PIG SLURRY FOLLOWING SEPARATION (CARNEY ET AL., 2011).....	36
FIGURE 3.1 BEAKERS PLACED IN FLOCCULATOR DURING AGITATOR TEST.....	43

FIGURE 3.2 UNITED STATES DEPARTMENT OF AGRICULTURE (USDA) SOIL TEXTURE CLASSIFICATION TRIANGLE USED TO DETERMINE SOIL TEXTURE	44
FIGURE 3.3 SCHEMATIC DIAGRAM OF SOIL SAMPLE IN AGITATOR	48
FIGURE 3.4 PHOSPHORUS CLASSIFICATION SYSTEM USED IN THIS STUDY (APHA, 1995).....	51
FIGURE 3.5 MASS OF DRP AND DRP CONCENTRATION IN OVERLYING WATER	52
FIGURE 3.6 TOTAL COST OF CHEMICAL AMENDMENT OF DAIRY CATTLE SLURRY PLOTTED AGAINST THE REDUCTION IN DISSOLVED REACTIVE PHOSPHORUS (DRP) LOST TO OVERLYING WATER AND THE PERCENTAGE REDUCTION IN DRP RELEASE TO OVERLYING WATER..	53
FIGURE 3.7 HISTOGRAM OF SLURRY PH AT TIME OF AMENDMENT/APPLICATION (CLEAR BOX) AND PH OF SLURRY AFTER 24 H (HATCHED BOX)	55
FIGURE 4.1 LANGMUIR ISOTHERM FITTED TO PHOSPHORUS IN AMENDED SLURRY DATA.....	62
FIGURE 4.2 PHOSPHORUS SORPTION ISOTHERMS FOR AMENDED SLURRY DATA	63
FIGURE 4.3 RUNOFF BOX IMMEDIATELY (A) BEFORE AND (B) AFTER SLURRY APPLICATION.....	65
FIGURE 4.4 PHOTOGRAPHS SHOWING SOIL SOD PREPARATION AND PLACEMENT METHODOLOGY	66
FIGURE 4.5 PHOTOGRAPHS OF SLURRY AND AMENDED SLURRY IMMEDIATELY AFTER APPLICATION TO GRASSED SOIL IN BOXES.....	69
FIGURE 4.6 THE AVERAGE FLOW-WEIGHTED MEAN CONCENTRATION OF DISSOLVED REACTIVE PHOSPHORUS (DRP), DISSOLVED UNREACTIVE PHOSPHORUS (DUP) AND PARTICULATE PHOSPHORUS (PP), WHICH COMPRISE TOTAL PHOSPHORUS (TP) IN RUNOFF FROM THREE RAINFALL SIMULATION EVENTS.....	71

FIGURE 4.7 THE AVERAGE % OF DISSOLVED REACTIVE PHOSPHORUS (DRP) DISSOLVED UNREACTIVE PHOSPHORUS (DUP) AND PARTICULATE PHOSPHORUS (PP), WHICH COMPRISE TOTAL PHOSPHORUS (TP) IN RUNOFF AFTER THREE RAINFALL SIMULATION EVENTS	73
FIGURE 4.8 AVERAGE FLOW-WEIGHTED MEAN CONCENTRATIONS OF SUSPENDED SEDIMENT IN RUNOFF	74
FIGURE 4.9 AVERAGE FLOW-WEIGHTED MEAN CONCENTRATIONS OF AL IN RUNOFF AND RAIN WATER	75
FIGURE 4.10 AVERAGE FLOW-WEIGHTED MEAN CONCENTRATIONS OF CA IN RUNOFF AND RAIN WATER	75
FIGURE 4.11 AVERAGE FLOW-WEIGHTED MEAN CONCENTRATIONS OF FE IN RUNOFF AND RAIN WATER	76
FIGURE 5.1 PHOTOGRAPH OF DYNAMIC CHAMBER APPARATUS	83
FIGURE 5.2 DIAGRAM OF APPARATUS USED TO MEASURE AMMONIA EMISSIONS	85
FIGURE 5.3 DYNAMIC CHAMBER	86
FIGURE 5.4 PHOTOGRAPH OF PAA DURING CARBON DIOXIDE, METHANE AND NITROUS OXIDE MEASURING PERIOD	88
FIGURE 5.5 CUMULATIVE AMMONIA EMISSIONS FROM UNTREATED AND CHEMICALLY AMENDED SLURRY EXPRESSED AS A PERCENTAGE OF TOTAL NITROGEN IN SLURRY AND AMMONIACAL NITROGEN IN SLURRY	90
FIGURE 5.6 NITROUS OXIDE EMISSIONS FROM SLURRY AND AMENDED SLURRY IN CHAMBERS (MEAN \pm STANDARD ERROR).....	92
FIGURE 5.7 CARBON DIOXIDE EMISSIONS FROM SLURRY AND AMENDED SLURRY IN CHAMBERS. (MEAN \pm STANDARD ERROR).....	93
FIGURE 5.8 CUMULATIVE CARBON DIOXIDE EMISSIONS FROM CHAMBERS FOR DURATION OF STUDY. (MEAN \pm STANDARD ERROR).....	93
FIGURE 5.9 METHANE EMISSIONS FROM SLURRY AND AMENDED SLURRY IN CHAMBERS. (MEAN \pm STANDARD ERROR).....	94

FIGURE 5.10 NITROGEN CUMULATIVE EMISSIONS (NITROUS OXIDE AND INDIRECT EMISSIONS RESULTING FROM AMMONIA LOSSES) EXPRESSED IN CO ₂ EQUIVALENTS. (MEAN ± STANDARD ERROR)	95
FIGURE 5.11 CUMULATIVE CARBON DIOXIDE (CO ₂), INDIRECT NITROUS OXIDE (N ₂ O), DIRECT N ₂ O AND METHANE (CH ₄) MEASURED DURING THE STUDY EXPRESSED IN CO ₂ EQUIVALENTS. (MEAN ± STANDARD ERROR).....	96
FIGURE 5.12 RELATIONSHIP BETWEEN SLURRY AND AMENDED SLURRY PH AT TIME OF APPLICATION AND (A) CUMULATIVE NH ₃ EMISSIONS AND (B) AND LOG OF TIME FOR HALF OF AMMONIA EMISSIONS TO OCCUR (T _{0.5}).....	99
FIGURE 6.1 MAP OF STUDY SITE SHOWING GROUND ELEVATION, TOPOGRAPHY, SLOPE, SOIL CONDUCTIVITY, GROUNDWATER FLOW DIRECTION, LOCATION OF SUBPLOTS AND OF GROUNDWATER WELLS.	106
FIGURE 6.2 PLOT SET UP AND RUNOFF COLLECTION PHOTOGRAPH	109
FIGURE 6.3 PHOTOGRAPHS OF RAINFALL SIMULATOR.....	111
FIGURE 6.4 NATURAL RAINFALL AND AVERAGE DEPTH OF SIMULATED RAINFALL RECEIVED BY THE PLOTS FOR EACH EVENT.....	112
FIGURE 6.5 PHOTO OF THE MEASUREMENT OF VOLUMETRIC WATER CONTENT OF SOIL USING TIME DOMAIN REFLECTOMETRY.....	113
FIGURE 6.6 AVERAGE FLOW-WEIGHTED MEAN CONCENTRATIONS OF DISSOLVED REACTIVE PHOSPHORUS (DRP), DISSOLVED UN-REACTIVE P (DUP) AND PARTICULATE P (PP) COMPRISING TOTAL P (TP) FOR THREE RAINFALL SIMULATION EVENTS, AND MAXIMUM ALLOWABLE CONCENTRATIONS (MAC) IN WATERWAYS.	115
FIGURE 6.7 AVERAGE FLOW-WEIGHTED MEAN CONCENTRATIONS OF AMMONIUM NITRATE (NH ₄ -N), NITRITE (NO ₂ -N) AND NITRATE (NO ₃ -N) FOR THREE RAINFALL SIMULATION EVENTS, AND MAXIMUM ALLOWABLE CONCENTRATIONS (MAC) IN WATERWAYS.	117

FIGURE 6.8 AVERAGE RAINFALL INTENSITY, RUNOFF VOLUME, TIME TO RUNOFF AND SOIL VOLUMETRIC WATER CONTENT FOR THE FIRST (RS1), SECOND (RS2) AND THIRD (RS3) RAINFALL EVENTS.....	118
FIGURE 7.1 SITE LOCATIONS SHOWN ON MAP OF IRELAND	127
FIGURE 7.2 SCHEMATIC OF PACKER USED TO ACHIEVE APPROXIMATE BULK DENSITY.....	130
FIGURE 7.3 WATER EXTRACTABLE PHOSPHORUS (WEP) OF INCUBATED SOIL SAMPLES AT EACH SAMPLING TIME (N=3)	135
FIGURE 7.4 SOIL TEST P OF INCUBATED SOIL SAMPLES AT EACH SAMPLING TIME (N=3).....	136
FIGURE 7.5 PH OF INCUBATED SOIL SAMPLES AT EACH SAMPLING TIME (N=3).....	137

LIST OF TABLES

TABLE 2.1 SUMMARY STATISTICS FROM 41 IRISH CATTLE SLURRY SAMPLES (MARTÍNEZ-SULLER ET AL., 2010).....	7
TABLE 2.2 RESULTS OF LABORATORY AND PLOT-SCALE RUNOFF STUDIES EXAMINING THE EFFECT OF LAND APPLICATION OF DAIRY CATTLE SLURRY ON P IN RUNOFF WATER FROM GRASSLANDS	12
TABLE 2.3 ALTERNATIVE SOIL TEST PHOSPHORUS ANALYSIS METHODS USED AROUND THE WORLD.....	14
TABLE 2.4 DILUTION RATES USED TO DETERMINE WEP OF SOIL.....	15
TABLE 2.5 PHOSPHORUS INDEX SYSTEM USED FOR IRISH GRASSLANDS (SCHULTE ET AL, 2010B).....	15
TABLE 2.6 AVERAGE P INDEX OF SOILS TESTED IN JOHNSTOWN CASTLE FOR THE PERIOD BETWEEN 2004 AND 2006 (MARK PLUNKETT, <i>PERS COM</i> , 2009)	16
TABLE 2.7 PERFORMANCE OF BUFFER STRIPS IN REDUCING TOTAL AND SOLUBLE PHOSPHORUS IN RUNOFF (ADAPTED FROM KAY ET AL., 2009)	31
TABLE 2.8 REVIEW OF LABORATORY-SCALE STUDIES EXAMINING CHEMICAL AIDED SEPARATION TO REDUCE P IN LIQUID FRACTION OF SEPARATED DAIRY CATTLE SLURRY.....	37
TABLE 2.9 RESULTS OF LABORATORY AND PLOT-SCALE CHEMICAL AMENDMENTS STUDIES TO DATE.....	39
TABLE 3.1 CHARACTERISATION OF PSMS AND ALUM USED IN THE AGITATOR TEST (MEAN ± STANDARD DEVIATION) TESTS CARRIED OUT IN TRIPLICATE	47
TABLE 3.2 TABLE SHOWING AMENDMENTS IN ORDER OF EFFECTIVENESS SCORE, BREAKDOWN OF COSTS ^A , COST/M ³ SLURRY ^B , COST FOR 100 COW FARM, PERCENTAGE REDUCTION IN DRP IN OVERLYING WATER AND WEP OF SLURRY AT 24 H	49
TABLE 3.3 FEASIBILITY OF AMENDMENTS	54

TABLE 4.1 STOICHIOMETRIC RATIO AT WHICH THE AMENDMENTS WERE APPLIED AND SLURRY DRY MATTER (DM), PH AND AVERAGE CONCENTRATIONS OF NH ₄ - N, WATER EXTRACTABLE PHOSPHORUS (WEP), TOTAL NITROGEN (TN), TOTAL PHOSPHORUS (TP) AND TOTAL POTASSIUM (TK) (N=3)	68
TABLE 4.2 RESULTS FROM CHAPTER 3 AND 4, SHOWING COST OF TREATMENTS AND TOTAL PHOSPHORUS (TP) LOST FROM RUNOFF BOX	72
TABLE 5.1 DAIRY CATTLE SLURRY AND AMENDED DAIRY CATTLE SLURRY PROPERTIES	89
TABLE 5.2. SUMMARY OF AMENDMENTS USED TO REDUCE AMMONIA EMISSIONS IN PREVIOUS STUDIES	98
TABLE 5.3 SUMMARY OF FEASIBILITY OF AMENDMENTS (ADAPTED FROM CHAPTER 3). MARKS FOR FEASIBILITY AND POLLUTION SWAPPING ARE FROM 1 TO 5. 1 = BEST 5 = WORST.....	102
TABLE 6.1 SOIL PH, MORGAN’S EXTRACTABLE P, K AND MG, SAND SILT, CLAY FRACTIONS, AND TEXTURAL CLASS OF SOIL USED IN THIS STUDY. THE LOCATION OF THE PIEZOMETERS IS ILLUSTRATED IN FIGURE 6.1	107
TABLE 6.2 THE AVERAGE SLOPE FOR EACH BLOCK, SOIL PH, WATER EXTRACTABLE PHOSPHORUS (WEP), MORGAN’S EXTRACTABLE P, POTASSIUM (K), AND MAGNESIUM (MG) BEFORE APPLICATION OF TREATMENTS.	108
TABLE 6.3 SLURRY DM, PH, WATER EXTRACTABLE PHOSPHORUS (WEP), TOTAL NITROGEN (TN), TOTAL PHOSPHORUS (TP) AND TOTAL POTASSIUM (TK) AND AVERAGE CONCENTRATIONS OF NH ₄ - N (N=5)	108
TABLE 7.1 SOIL PHYSICAL AND CHEMICAL PROPERTIES.....	129
TABLE 7.2 SLURRY PROPERTIES.....	130
TABLE 8.1 SUMMARY OF FEASIBILITY OF AMENDMENTS (ADAPTED FROM CHAPTER 3). MARKS FOR FEASIBILITY, POLLUTION SWAPPING,	

INCUBATION STUDY AND PLOT STUDY ARE FROM 1 TO 5. 1 = BEST; 5 =
WORST..... 143

Chapter 1 Introduction

1.1. Overview

In Ireland, agriculture is an important national industry that involves approximately 270,000 people, 6.191 million cattle, 4.257 million sheep, 1.678 million pigs and 10.7 million poultry (CSO, 2006). It utilizes 64% of Ireland's land area (Fingleton and Cushion, 1999), of which 91% is devoted to grass, silage and hay, and rough grazing (DAFF, 2008). Livestock production is associated with external inputs of nitrogen (N) and phosphorus (P), which include inorganic and organic fertilizers. Land application of fertilisers followed by a rainfall event can result in incidental losses of P to runoff. In addition, chronic P losses from the soil as a result of a build up in soil test P (STP) can also contribute to losses in other times of the agricultural calendar. Land application of fertilisers also result in N leaching through the soil to surface and ground waters. In practice P is of particular importance as it is the critical nutrient in fresh water systems. In order for Ireland to comply with the requirements of the European Union Water Framework Directive (EU WFD; 2000/60/EC, OJEC, 2000) to achieve at least 'good status' of all surface and groundwater by 2015, programmes of measures (POM) should be in place to prevent such losses. Ireland's agricultural POM is the Nitrates Directive (SI 610 of 2010). These measures have addressed the problem by limiting fertiliser application rates and improving manure management. Particular focus has been given to time of application and increasing slurry storage capacity on farms. A possible supplementary mitigation method is the chemical amendment of slurries. However, before chemical amendment of dairy cattle slurry may be considered for implementation in Ireland, there is a need for an extensive study of their use.

The aim of this study is to examine the: (1) effectiveness of different amendments to prevent P losses in runoff (2) feasibility of the different amendments to be used on a farm (3) risk of metal release to overland flow and (4) possibility of ‘pollution swapping’ (defined by Stevens and Quinton (2009) as the increase in one pollutant as a result of a measure introduced to reduce a different pollutant). The present study comprised laboratory and field-scale experiments, which were designed to address knowledge gaps in these areas. For the first time in Ireland, a series of experiments were conducted to examine the possibility of bringing such a supplementary mitigation measure to Irish farms.

The specific objectives of this study were:

1. To review existing and emerging P mitigation measures for the control of P losses arising from the land application of dairy cattle slurry to grasslands in Ireland. Following this, the study aimed to select a measure suitable for further study and to identify knowledge gaps which need to be addressed in order for this measure to be considered for implementation at farm scale.
2. To evaluate the effectiveness and feasibility of potential chemical amendments and to use such criteria to select the most suitable amendment for trial at field scale.
3. In parallel to the P mitigation experiments, to examine the effects of pollution swapping, the loss of N chemical species in runoff and gaseous emissions of ammonia (NH₃) and greenhouse gases (GHG) to the atmosphere. In addition, this study aims to examine the effect of chemical amendment of dairy cattle of slurry on metal losses in runoff.
4. To examine the effect of chemical amendment of dairy cattle slurry prior to application to soil on long-term soil water extractable phosphorus (WEP) and plant available P.

5. To examine the effect of soil type on P solubility in amended slurry applied to soil.

1.2. Procedure

A literature review of P loss mitigation technologies with the potential to reduce P losses arising from land application of dairy cattle slurry was undertaken. Chemical amendment of dairy cattle slurry was chosen for further study as chemical amendments have the ability to be quickly implemented, are cost effective and capable of being used in strategic locations for maximum benefit i.e. no capital cost or need to transport slurry long distances. Several knowledge gaps were identified and experiments were designed accordingly.

Following this, a novel experiment (an ‘agitator test’) was used to determine the most suitable amendments for addition to dairy cattle slurry with the aim of reducing P loss in runoff. In this experiment, potential amendments (alum, aluminium chloride, ferric chloride (FeCl_2), flyash, flue gas desulphurisation by-product (FGD), lime, poly-aluminium chloride hydroxide (PAC) and water treatment residuals (WTR)) were added to slurry before slurry was applied to intact soil cores, which were overlain by water in a 1-L beaker. The overlying water was then stirred to simulate overland flow. The agitator test successfully identified amendments with the potential to reduce dissolved reactive phosphorus (DRP) in overlying water.

The most feasible amendments (alum, PAC, FeCl_2 and lime) were then examined in a runoff study conducted using laboratory runoff boxes subjected to simulated rainfall applied at an intensity of 11.5 mm h^{-1} to develop a greater understanding of how chemical amendments affected different forms of P in runoff.

It is critical that the potential for ‘pollution swapping’ is examined when evaluating a potential P mitigating technology such as those examined in this study. In particular, the

effects of any proposed treatments on GHG emissions must be examined. To address this, a laboratory chamber experiment was used to examine the effect of chemical amendment of dairy cattle slurry on emissions of NH₃, nitrous oxide (N₂O), methane (CH₄) and carbon dioxide (CO₂). This allowed for the pollution swapping potential of amendments to be considered in the selection of amendments chosen for field scale study.

The most feasible amendments were then examined at micro field plot-scale in Johnstown Castle, Co. Wexford. Twenty five plots, each measuring 0.4 m-wide by 0.9 m-long, were hydraulically isolated before being amended with untreated or chemically amended dairy cattle slurry. Three rainfall simulations were conducted over a period of one month and the surface runoff was collected for half an hour during each event.

Finally, a laboratory incubation experiment was conducted to examine (1) the effect of amendments on the long-term plant availability of P in soil and (2) the effect of soil type on stability of reductions in P solubility. Five soils were subjected to six treatments (soil only, slurry only and four chemically amended slurries) and destructively sampled at 0, 3, 6 and 9 months from the start of the experiment.

1.3. Structure of dissertation

Chapter 2 reviews the current water quality status in Ireland and the impact of agriculture, particularly dairy cattle slurry, on water quality. Chapter 2 also focuses on Ireland's performance in relation to WFD water guidelines, with particular focus on the potential need to explore P mitigating measures for possible implementation if current measures are not sufficient to meet targets. Chapter 3 details the results of the agitator test which was used to evaluate the effectiveness and appropriate application rates for amendments. Chapter 3 also examines the feasibility of amendments and a detailed cost analysis is presented. Chapter 4 describes the results of a laboratory-scale runoff-box study. Chapter 5 details the results of the gas chamber experiments designed to examine the pollution swapping potential of amendments. Chapter 6 details the results of a plot-scale runoff experiment conducted in Johnstown Castle Research Centre. Chapter 7 details the results

of the nine-month incubation experiment. Finally, in Chapter 8, conclusions from the study are presented and recommendations for future research work are made.

To date, two international peer review papers have been published from this work:

Brennan, R.B., Fenton, O., Rodgers, M., Healy, M.G. 2011. Evaluation of chemical amendments to control phosphorus losses from dairy slurry. *Soil Use and Management* 27: 238-246.

Brennan, R.B., Fenton, O., Grant, J., Healy, M.G. 2011. Impact of chemical amendment of dairy cattle slurry on phosphorus, suspended sediment and metal loss to runoff from a grassland soil. *Science of the Total Environment* 403(23): 5111-5118.

A number of international and national conference papers have also been published describing this work. A list of outputs and manuscripts in preparation for submission to international journals are listed in Appendix A.

Chapter 2 Literature review

2.1. Overview

This chapter introduces Irish agriculture, details Ireland's current water status under the WFD and comments on the impact which agriculture has on this status. In addition it details where nutrient losses occur from an agriculture system and investigates several mitigation options to prevent such losses.

2.2. Agriculture in Ireland

Agriculture accounts for approximately 56% of land use in the Republic of Ireland (CSO, 2009). Each year approximately 29 million tonnes of slurry are produced in Ireland, of which 28% is produced by dairy cattle (Hyde and Carton, 2005). Dairy produce and ingredients amounted to 29% of the value of all agricultural goods, and were estimated at €5.7 billion at producer prices in 2007 (Common Agricultural Policy, 2011). This is expected to increase as worldwide demand for dairy products increases (More, 2009).

Dairy cattle slurry may be defined as either 'the excreta produced by livestock while in a building or yard, or a mixture of such excreta with rainwater, washings or other extraneous material, or any combination of these' (Statutory Instrument (SI) 610 of 2010). In Ireland intensive dairy farms (intensively managed farms operate with the objective of maximising output per unit area with high levels of artificial inputs i.e. concentrated feeds and artificial fertiliser). Cattle are typically housed in slatted sheds for between 16 and 18 weeks in the winter months, during which time they are fed silage and concentrates. During this time, the cow manure and urine produced are collected and stored in storage tanks for the winter period. Slurry is rich in nutrients (particularly N, P

and potassium (K)), and is generally land applied in the spring and summer months as a fertiliser. An average Irish slurry sample contains 5 kg total nitrogen (TN) m⁻³ and 0.8 kg total phosphorus (TP) m⁻³ (SI 610 of 2010). Martínez-Suller et al. (2010) conducted a study of Irish cattle slurry, the results of which are shown in Table 2.1. Slurry is a valuable fertiliser (Lalor and Schulte, 2008a) and it is important that any change in slurry management takes account of the fertiliser value of slurry. Immediately prior to land application, slurry is agitated to improve workability of slurry, to ensure consistency of nutrient concentrations in the slurry and to allow uniform application. After agitation, slurry is land applied using a slurry spreader. Although research has been carried out on alternative spreading techniques such as trailing shoe application (Lalor and Schulte, 2008b) the majority of slurry is applied using a splash plate slurry spreader (Ryan, 2005).

Table 2.1 Summary statistics from 41 Irish cattle slurry samples (Martínez-Suller et al., 2010)

Variable	Mean	Median	Maximum	Minimum	sd	CV (%)
pH	7.3	7.3	7.8	6.8	0.2	2.9
EC (S m ⁻¹)	1.43	1.6	2.33	4.1	4.9	34
Dry Matter (g kg ⁻¹)	62.7	65.1	97.3	5.7	20.7	33
N (kg m ⁻³)	3.43	3.27	7.03	0.36	1.4	41
P (kg m ⁻³)	0.56	0.61	1.13	0.04	0.25	44
K (kg m ⁻³)	4.41	4.91	7.75	0.94	2.04	46

sd = standard deviation; CV = coefficient of variation

In concentrated feeding systems such as intensive dairy farms, P inputs into a farm may exceed P outputs (Tunney, 1990). This may give rise to a build-up of STP (Sharpley et al., 2004) as a result of land application of dairy cattle slurry to grassland, which poses a risk to water quality. In addition, losses during and after land spreading also pose risk to a waterbody. Therefore, there is a need for the development of management practices, which allow maximum production with minimum negative environmental impacts i.e. livestock numbers will not reduce.

2.3. Legislation and compliance

The EU WFD (OJEC, 2000) aims to achieve at least “good ecological status” in all waterbodies by 2015 through the implementation of POM by 2012. In Ireland the agricultural POM is the Nitrates Directive (EEC, 1991). The Nitrates Directive has been implemented since 2009. Huge investment in farm infrastructure has resulted in reduced P losses from agricultural point sources. Guidelines for farm management provide best management practice for slurry and inorganic fertiliser application to grassland to minimize diffuse P losses and increased STP. An Agricultural Catchments Programme has been established to evaluate catchment-scale evaluation of their effectiveness (Schulte et al., 2010a).

The statutory instrument which governs agricultural practice in Ireland is The European Communities (Good Agricultural Practice for Protection of Waters) Regulations 2010 (SI 610 of 2010). This places a responsibility on the individual farmer and the public authority to adhere to the conditions set out within the Nitrates Directive (EEC, 1991) and the WFD. Individual farmers are required to maintain records of activities with regard to soil testing, storage capacity, nutrient management, minimum storage period, and periods when application to land is prohibited. Land spreading of slurry is forbidden if (1) heavy rainfall is forecast within the 48 h of application (2) land is frozen or snow-covered (3) the land slopes steeply towards a river or stream, or (4) slurry is to be applied directly to bedrock (SI 610 of 2010). In addition to the POM, the WFD recommends research and development of new pollution mitigation measures to achieve the 2015 target.

2.4. Current water quality status in Ireland

The Irish Environment Protection Agency (EPA) has reported findings based on analyses of 2,985 sampling locations on 1,151 rivers between 2007 and 2009 (McGarrigle et al., 2011). Approximately 68.9% of Ireland’s rivers were unpolluted, 20.7% were slightly polluted, 10% were moderately polluted and 0.4% were seriously polluted (McGarrigle et al., 2011). When these rivers were assessed for ecological status, based on the various

biological and physico-chemical quality elements, only 52% of water bodies achieved 'good status'. Diffuse losses (including those from agricultural and other sources) were responsible for approximately half of the polluted sites monitored. Similarly, using the traditional method of assessment, 92.1% of lakes were in an un-enriched, oligotrophic status - similar to that observed for 2004-2006 period. However, according to the requirements of the WFD, 47.5% were of 'good status'. The report also examined measurements from 211 groundwater monitoring stations: 84.7% of ground water bodies were in good status, while 15.3% were in poor status. Figure 2.1 shows the decline in poor status for groundwater. This reduction was attributed to increased rainfall, reductions in inorganic fertiliser usage, improved organic fertiliser storage, and implementation restrictions on timing of land applications. The McGarrigle et al. (2011) report concluded that substantial measures will be required for Ireland to comply with the objectives of the WFD.

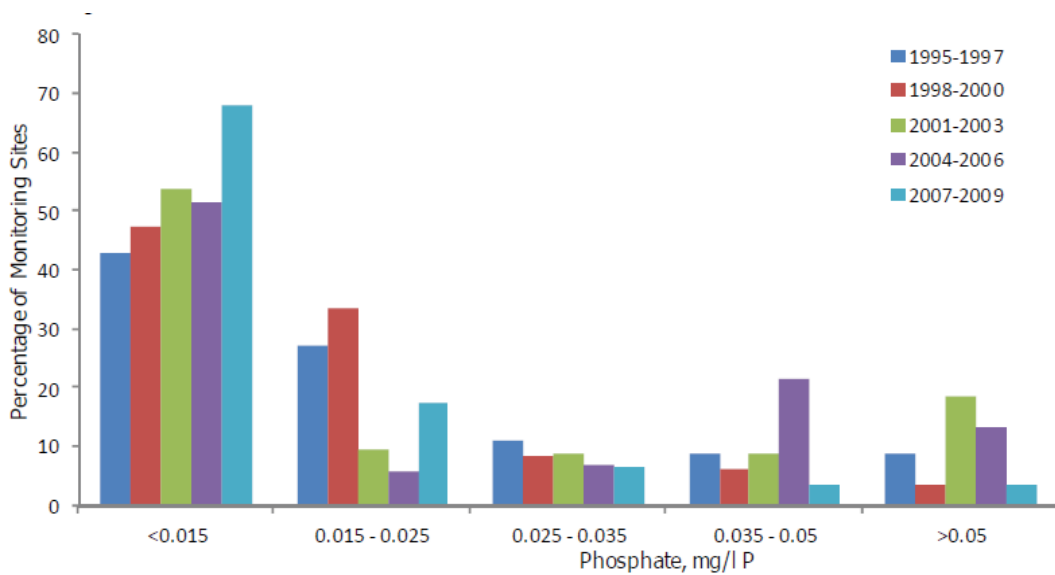

Figure 2.1 Number of ground water monitoring sites with phosphate concentrations from 1995 to 2009 (McGarrigle et al., 2011)

2.5. Impact of agriculture on water quality

Agricultural activities are thought to be responsible for approximately 38% of slightly polluted rivers, 23% of moderately polluted, and 29% seriously polluted rivers (McGarrigle et al., 2011). Figure 2.2 shows the number of reported fish kills attributed to agriculture from 1971 to 2009 (McGarrigle et al., 2011). The impact of agriculture on water has reduced steadily since 1997; however, further reductions are required to meet the requirements of the WFD (McGarrigle et al., 2011). It is important to note that research constantly challenges the accuracy of the estimated contribution which agriculture makes to pollution of Irish rivers. This contribution is currently being examined as part of the Agricultural Catchments Programme.

McGarrigle et al. (2011) found that 0.3% of the waterbodies in the Republic of Ireland were of ‘poor status’ due to nitrate (NO₃), compared to 13.3% due to P. Therefore, in Ireland future mitigation measures must focus on P losses with emphasis on diffuse losses from agriculture.

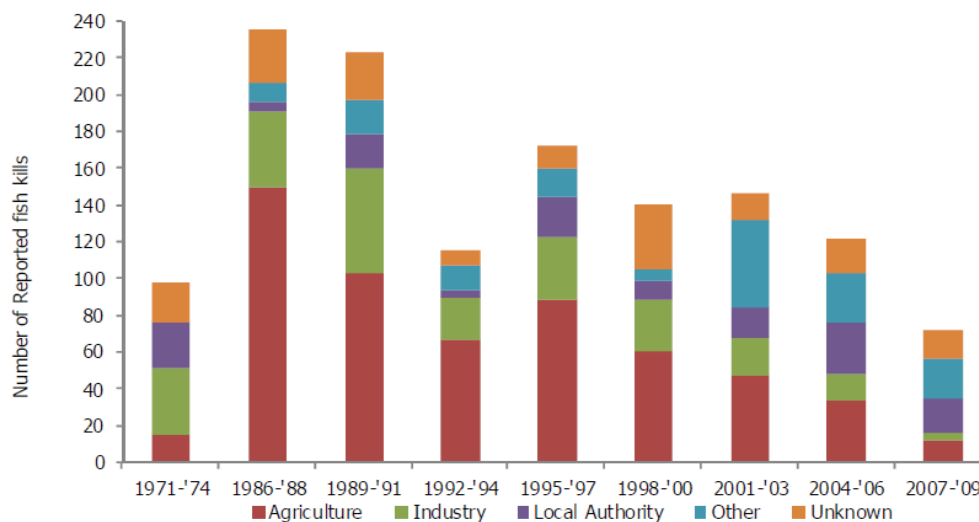

Figure 2.2 Number of reported fish kills attributed to agriculture, industry, local authority, other and unknown sources (McGarrigle et al., 2011)

2.6. Nutrients loss and pathways during land application of dairy slurry

Throughout the EU and U.S.A. agricultural management has been identified as a landscape pressure impacting on water quality (Sharpley et al., 2001a, b; Schulte et al., 2006; Stark and Richards, 2008; Kronvang et al., 2009). Transfers of N and P from agriculture to water can lead to eutrophication and may occur in three ways: (1) as point source losses from farmyards because of excessive rates of soiled water application through the use of rotational irrigators; (2) as diffuse losses from soil, which are related to soil P and N concentrations in excess of crop requirements; and 3) as incidental losses from direct losses of fertilizer or manures to water during slurry application, or where a rainfall event occurs immediately after application (Preedy et al., 2001). Diffuse P losses, specifically incidental and chronic P losses arising from land application of dairy cattle slurry to grasslands in Ireland, are thus the focus of this study.

2.7. Phosphorus

Phosphorus is an essential nutrient for plant growth, and land application of organic and inorganic P fertiliser is needed to maintain profitable animal and crop production (Sharpley et al., 2003). In concentrated feeding systems such as intensive dairy farms, P inputs into a farm can exceed P outputs (Tunney, 1990). This can give rise to high STP soils which pose a risk to water quality. Phosphorus is also of particular importance in fresh water systems as it is the limiting nutrient for the occurrence of eutrophication (Correll, 1998; Sharpley and Tunney, 2000). Transfers of P from agriculture to water can lead to eutrophication of a waterbody (Carpenter et al., 1998). Land application of dairy slurry can result in incidental and chronic P losses to a waterbody (Buda et al., 2009). Incidental P losses take place when a rainfall event occurs shortly after slurry application and before slurry infiltrates the soil, while chronic P losses is a long-term loss of P from soil as a result of a build-up in STP caused by application of inorganic fertilisers and manure (Buda et al., 2009). Table 2.2 shows a summary of the results of laboratory and plot-scale runoff studies examining the effect of land application of dairy cattle slurry on DRP and TP concentrations in runoff water from grasslands. These results show the

importance of timing of rainfall event following slurry application. In addition this table identifies a need to examine runoff from slurry at lower more realistic rainfall intensities.

Table 2.2 Results of laboratory and plot-scale runoff studies examining the effect of land application of dairy cattle slurry on P in runoff water from grasslands

Reference	Type	Size m ²	Intensity mm h ⁻¹	----- slurry -----		----- runoff -----		Time after application Days	Runoff mm
				WEP kg ha ⁻¹	TP kg ha ⁻¹	DRP mg L ⁻¹	TP mg L ⁻¹		
Kleinman and Sharpley (2003)	Box	1 x 0.2	70	14	50	3.2 1.85 1.5	6.35 3.2 2	3 10 24	
Smith et al. (2001c)	Plot	2 x 15	Natural		43		0.35	130 ^a	5.4
Elliott et al. (2005)	Box	1 x 0.2	71	41.6	122		10.9	3	
Hanrahan et al. (2009)	Box	1 x 0.2	30		30	10.3 3.1 3.6	48 5 4.1	2 5 9	
Preedy et al. (2001)	Plot	3 x 10	Natural		29		7	7*	48

^aRunoff collected for duration of study

2.7.1. Phosphorus in soil

The soil P cycle is shown in Figure 2.3. Phosphorus exists in organic and inorganic forms, and may be simplified into three types of P: (1) slow inorganic P (2) rapid cycling organic and inorganic P and (3) slow organic P. This is a dynamic equilibrium system and transformations between forms occur continuously (Sharpley, 1995). The availability of P to plants and water in contact with soil is controlled by chemical processes within the soil (Sharpley, 1995).

2.7.2. Methods used to determine risk of P loss to water

The slow inorganic pool provides P to replenish the solution P pool, and comprises inorganic P attached to small particles or elements, such as aluminium (Al) and calcium (Ca), and organic P that is easily mineralised. The rapid cycling of organic and inorganic P makes up a small proportion of total P in the soil, and is the most available to plants and to overland and subsurface flow. It is constantly being depleted and replenished from

slow organic and inorganic P pools. Microbial P has an important role in short-term dynamics of organic P transformations and has a significant effect on P availability. Inorganic manure applications increase microbial activity in the soil, which leads to increased P availability. The slow organic pool contains compounds that are insoluble and organic P, which is less liable to mineralisation.

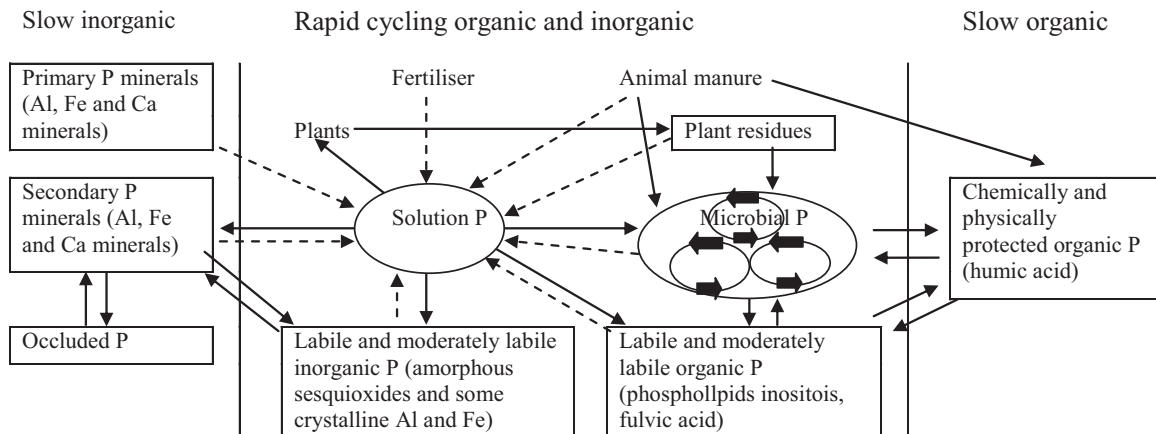

Figure 2.3 The soil P cycle: its components and measurable fractions (Steward and Sharpley, 1987)

Tests were initially developed to measure availability of P for agronomic purposes, with loss of P to water from soil not considered a priority. Studies found that P losses from soil were a major water quality concern (Sharpley and Rekolainen, 1997) and water quality became the focus of soil P testing. Commercial analysis is focused on testing methods which measure plant available P. However, researchers have found a relationship between STP and DRP in surface runoff (Regan et al, 2010; Little et al, 2007). Soil test P has been shown to be the main factor influencing P concentrations in runoff if no fertilisers have recently been applied (DeLaune et al., 2004; Dougherty et al., 2008). Different tests for the determination of STP have been adopted internationally depending on soil types and tradition (Table 2.3).

Studies have shown that the STP in the upper 20 mm of grassland soils tends to be higher than for the equivalent depth in tillage soils receiving the same manure (Ahuja et al.,

1981). This is due to the absence of deep tilling, which ploughs the nutrients into the soil (Andraski et al., 2003; Sharpley, 2003). It has also been shown that the use of 100 mm sampling depth (used to determine the Morgan's P of the soil) underestimates P loss risk from soils and grasslands in particular (Humphreys et al., 1999). Mulqueen et al. (2004) recommended reducing the sampling depth to improve environmental risk prediction; however, Schroeder et al. (2004) reported that sample depth (2, 5 and 10 cm) had no effect on the relationship between soil P concentration and P concentration in runoff. Daly and Casey (2005) conducted an extensive review of sampling depth and concluded that the sampling depth of 100 mm was best. This was primarily due to the huge variability with smaller sampling depths. Torbert et al (2002) reported greater variation when sampling soil to a depth of 25 mm compared to 100 and 150 mm. It was suggested that this could be a result of a combination of an increased sensitivity of the testing procedure to 'hot spots' of manure in the field and difficulty in obtaining a consistent sample.

Table 2.3 Alternative soil test phosphorus analysis methods used around the world

Method	Soil	Countries
Bray 1 (Bray and Kurtz, 1945)	Acidic to slightly alkaline (<6 to 7.2)	UK and Australia
Mehlich 1 and Mehlich 3 (Mehlich 1984)	Acidic to slightly alkaline (<6 to 7.2)	Europe and U.S.A.
Olsen P (Olsen et al., 1954)	Slightly acidic to alkaline (6.0 to >7.2)	UK
Morgan's P (Morgan, 1941)	Acidic to slightly alkaline (<6 to 7.2)	Ireland

The WEP test was developed to measure the environmental risk posed by P in any soil. The WEP test is also used to determine the risk of P loss from manures applied to grassland. In this test, soil is mixed with water to replicate soil and water interactions and to estimate dissolved P losses from soil. The general procedure is to weigh accurately a mass of soil into a known volume of distilled water in an un-reactive container and to shake for a time between 30 and 60 min. After shaking, the solution is centrifuged and passed through a 0.45 µm filter. Different dilution ratios commonly used are shown in Table 2.4.

Table 2.4 Dilution rates used to determine WEP of soil

Author	Dilution ratio	Type of study
Regan et al. (2010)	1:80	Runoff box
Pote et al. (2003)	1:25	Field
McDowell and Sharpley (2001)	1:5 1:100	Incubation

Schulte et al. (2010b) showed that it may take many years for elevated STP concentrations to be reduced to optimum levels to reduce risk to water quality. In Ireland, a P index system is used to quantify risk of P loss from a soil (Table 2.5). There are 4 categories, with Index 1 representing a P deficient soil and Index 4 (STP > 8 mg P L⁻¹) representing a grassland soil which presents a risk to water quality (Tunney, 2000). While the onset of reductions in excessive STP levels may be observed within five years, this reduction is a slow process and it may take up to 20 years for P index 4 soils to complete the reduction to the boundary Index 3 (a STP of between 5.1 and 8 mg P L⁻¹) (Schulte et al., 2010b).

Table 2.5 Phosphorus Index system used for Irish grasslands (Schulte et al, 2010b)

Soil P index	Morgan's soil P range for grassland soils (mg L ⁻¹)	Interpretation
1	0.0-3.0	Soil is P deficient; build-up of soil P required. Insignificant risk of P loss to water
2	3.1-5.0	Low soil P status: build-up of soil P is required for productive agriculture. Very low risk of P loss to water
3	5.1-8.0	Target soil P status: only maintenance rates of P required. Low risk of P loss to water
4	>8.0	Excess soil P status: no agronomic response to P applications. Risk of P loss to water increases within this index

The STP levels and the difference between available and total P for Irish soils can mostly be explained by land use, rock and soil type. Table 2.6 shows the average percentage of soils in each P index for all soil samples tested in Teagasc, Johnstown Castle between 2004 and 2006 (Mark Plunkett *pers com*, 2009). Phosphorus losses from agricultural soils

are generally a result of an increase in STP caused by long-term applications of P fertilisers (Frossard et al., 2000).

Table 2.6 Average P index of soils tested in Johnstown castle for the period between 2004 and 2006 (Mark Plunkett, *pers com*, 2009)

Soil P index	STP mg L ⁻¹	Grassland %	Tillage %
1	0.0-3.0	15	15
2	3.1-6.0	25	30
3	6.1-10.0	27	23
4	>10.0	33	32

In 2008 the Phosphorus Index system was amended (Lalor and Coulter, 2008).

2.8. Nitrogen

Nitrogen is the most abundant gas in the atmosphere and can exist in various compounds. The process by which N is transformed to its various forms is called the N cycle (Figure 2.4) (Ketterings et al., 2011). The major conversion processes which make up the N cycle are: N fixation, mineralisation, nitrification, denitrification, ammonia volatilisation, and immobilisation.

Biological N fixation is a process by which soil bacteria and plant roots interact to convert nitrogen gas (N₂) in the atmosphere to proteins. In industrial production, the Haber-Bosch process is used to combine N₂ and hydrogen gas (H₂) with a catalyst under intense heat and pressure for form NH₃, which is then used to make fertiliser. Biological N fixation requires plant energy so if available N exists, the plant will use this before biological fixation takes place (Ketterings et al., 2011). Mineralisation is the process that converts organic N in soil, manure and decaying plants to inorganic forms (ammonium (NH₄) and NH₃). Nitrification occurs when microbes use enzymes to convert NH₄ to nitrite (NO₂) and then NO₃ to obtain energy. Warm, moist and aerated conditions favour nitrification.

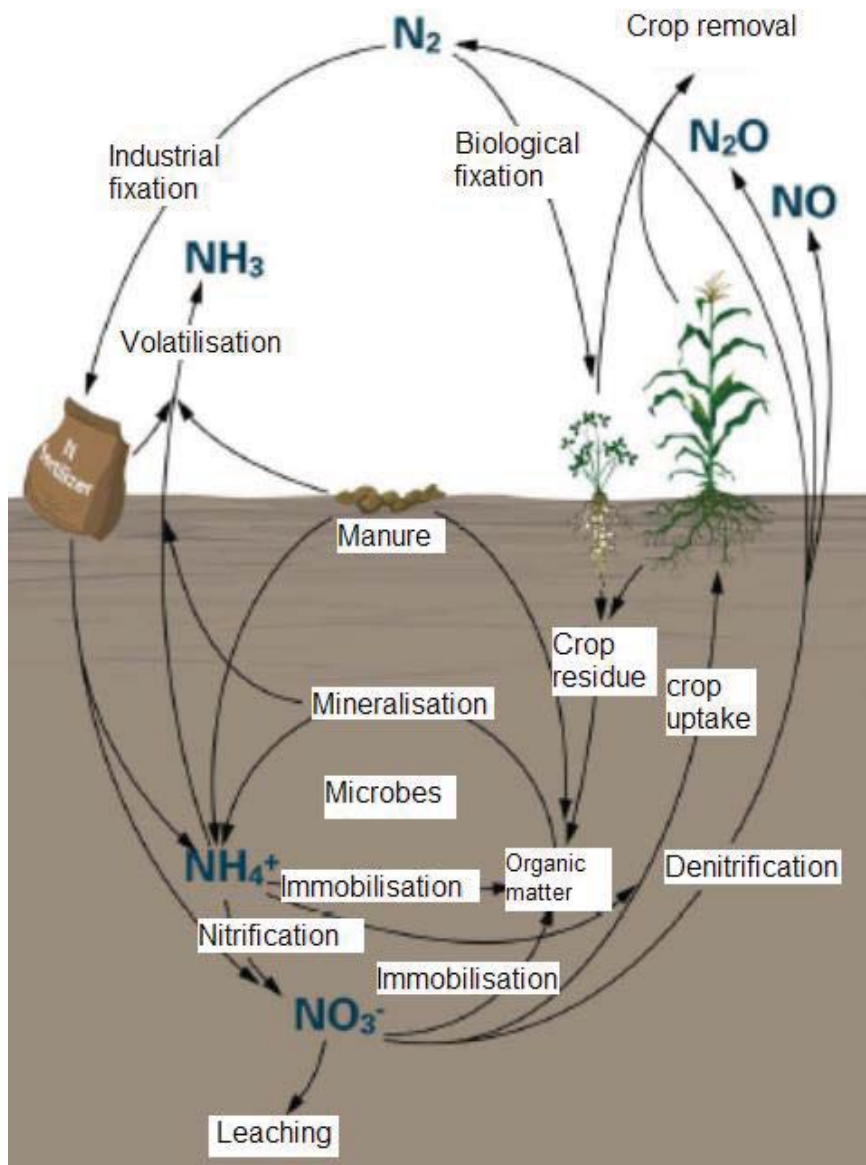
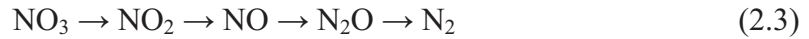

Figure 2.4 Schematic of the soil N cycle (Ketterings et al., 2011)



Denitrification is the process by which N is lost from the soil through the conversion of NO_3 to various gaseous forms of N. Significantly, this reaction can produce N_2O , which is a potent GHG. Therefore, treatments such as chemical amendment of dairy cattle slurry

which could potentially change the N cycle, and could impact N₂O release. Wet, poorly drained soil favours the occurrence of denitrification.



Ammonia volatilisation is the production and release of NH₃ from NH₄ on the soil surface. Ammonia losses are greatest in soils with high pH and in dry, warm and windy weather (Ketterings et al., 2011). Immediately following land application of dairy cattle slurry, there is an initial peak in NH₃ emissions and it is estimated that 60% of ammonical nitrogen (NH₄-N) applied is lost during land spreading of cattle slurry (Hyde et al., 2003). There exists a state of equilibrium between the NH₃ in the slurry/soil interface and the NH₃ in the air immediately above the soil surface (Génermont and Cellier, 1997). The pH of the slurry/soil combination has also been observed to affect the rate of NH₃ volatilisation. Depending on the pH, NH₄-N can occur as NH₃ gas or the ammonium ion (NH₄⁺) (Gay and Knowlton, 2005). The relationship between NH₄ and NH₃ as a function of pH is shown in Figure 2.5.

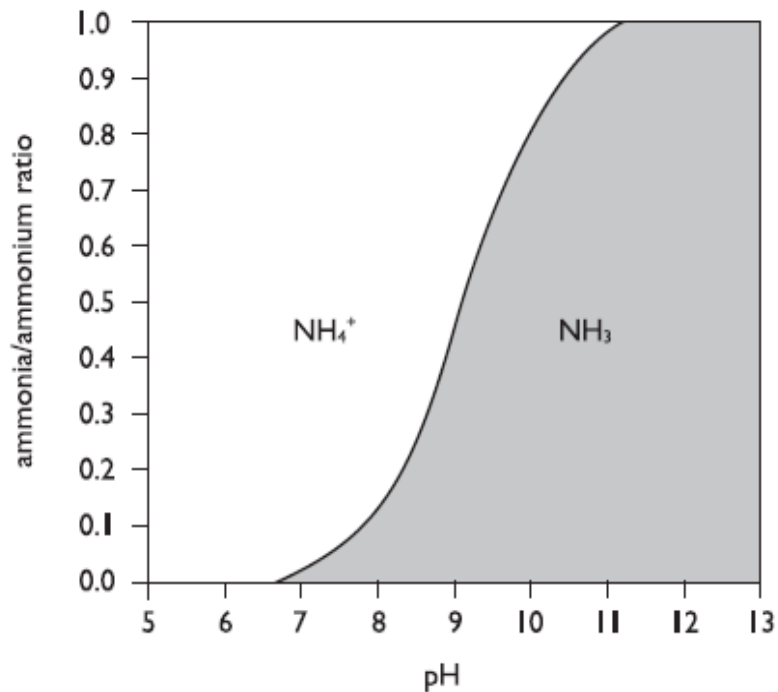

Figure 2.5 Relationship between the ammonia/ammonium (NH₃/NH₄⁺) ratio and pH (Gay and Knowlton, 2005)

Immobilisation is the reverse of mineralisation and occurs when microbes temporarily bind available N in soil biomass (Ketterings et al., 2011). Nitrogen can be lost to surface ground waters (Stark and Richards, 2008) and to the atmosphere in gaseous form (Ketterings et al., 2011). On a farm, N losses are spatial in nature and occur from the entire farm, while P losses can be due to small portion of farm (Poinke et al., 2000) called Critical Source Areas (CSAs). Therefore, measures to reduce P loss that are applied through a farm may have a greater effect on N loss than P loss.

2.9. Loss of soluble and particulate nutrients in runoff

Nutrients can be lost to a surface waterbody in particulate and soluble forms. Suspended Sediment (SS) loss contributes to particulate phosphorus (PP) in runoff from tillage soils (Regan et al., 2010); however, in grasslands most P loss is in dissolved form with Total Dissolved Phosphorus (TDP) and DRP making up 69% and 60% of TP load in surface runoff (Haygarth et al., 1998). Incidental SS losses following slurry application can result in high concentrations of SS in runoff, resulting in increased PP losses (Preedy et al., 2001). This PP can be mineralised and become available to algae (Sharpley, 1993). Withers et al. (2003) examined the results of a number of studies examining P losses following land application of dairy cattle slurry at different rates and under different climatic conditions (Smith et al., 2001c; Withers et al., 2001; Withers and Bailey, 2003) and found that incidental P losses can account for between 50 and 90% of P losses from land to water. These variations are due to difference site and climatic conditions.

2.9.1. Soluble nutrient loss

The processes involved in transfer of soluble P from soil or slurry to water are similar. Phosphorus release occurs as a result of the processes of precipitation-dissolution and adsorption-desorption (Frossard et al., 2000). Soluble P losses dominate P loss from grasslands (Sharpley et al., 1992). Kleinman et al. (2006) found that concentration of water soluble P in manure was strongly related to DRP in runoff from three soils examined.

Nitrate is the form of N most available to plants and to runoff, and makes up to approximately 2% of soil N at any time (Ryan et al., 2008). This NO_3 is constantly replenished if N is lost, and is very soluble and easily taken up from soil by runoff (Ryan et al., 2008). Although P is the limiting nutrient in freshwater systems (Correll, 1998), N losses also pose a significant risk to water quality (Johnes et al., 2007; Vitousek et al., 2009). It is recommended that slurry should be applied in spring time to maximise N efficiency (Lalor and Schulte, 2008) and to reduce risk of leaching of N to groundwater, as less NO_3 is lost when plants are growing and fertiliser is applied at rates corresponding to the requirements of the crop being grown (Power and Schepers, 1989). In a lysimeter study which examined NO_3 losses from five different soil types, Ryan and Fanning (1996) found that winter applications of pig and dairy cattle slurry resulted in higher NO_3 losses than spring applications. This is most likely due to uptake of NO_3 by plants during the spring when plants are growing.

2.9.2. Particulate nutrient loss

Erosion of soil or surface runoff of land applied slurry by water occurs predominantly as a result of the processes of detachment (caused by the impact of the raindrops on the soil/slurry surface) or by erosion mechanisms such as entrainment and re-entrainment. As the processes of soil erosion and runoff of land applied slurry are analogous to one another, the fundamental mechanisms of surface runoff of land applied slurry will be discussed in the context of soil erosion.

Detachment of the soil particles from the soil surface is due to the impact of the raindrops falling under gravity on the ground (Figure 2.6). The cohesive bonds between the soil particles are brittle, and, once broken, the cohesive strength of the soil is lost. Provided the infiltration rate is greater than the rainfall rate, the soil particles will return to the soil surface. If rainwater accumulates on the surface, erosion can occur and the detachment process will continue. The risk of SS and P loss to surface waters in a rainfall event decreases dramatically with an increase in time from slurry application to start of the rainfall event (Smith et al., 2007; Allen and Mallarino, 2008; Hanrahan et al., 2009).

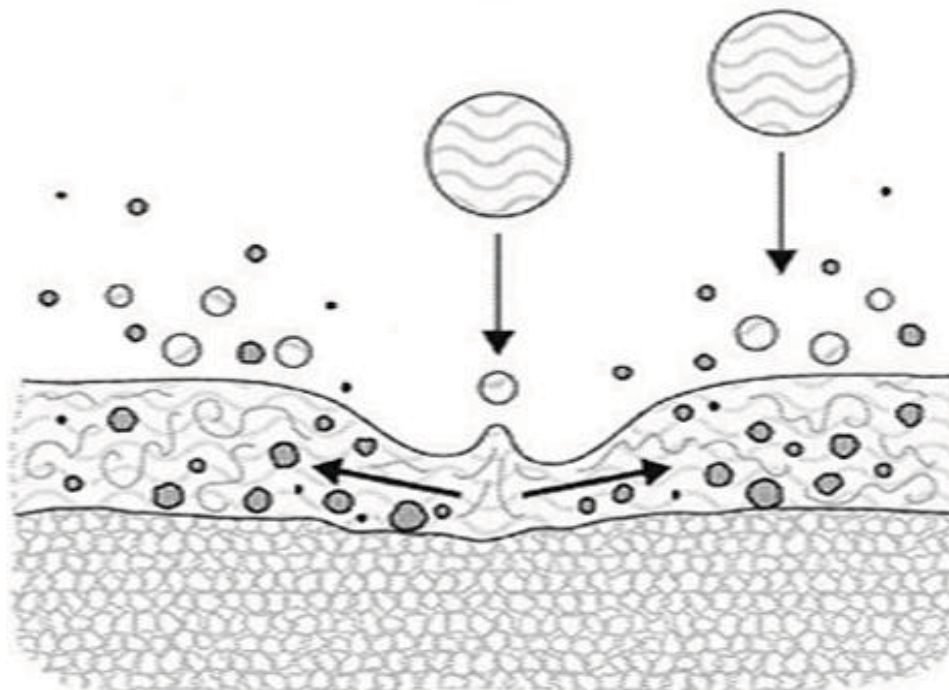

Figure 2.6 Detachment of soil particles in a rainfall event (Rose, 2004)

The potential for P loss peaks and then declines over time, as P applied in slurry interacts with the soil (Edwards and Daniel, 1993). The processes for slurry SS loss are similar to soil erosion processes. Hanrahan et al. (2009) reported that TP and DRP concentrations were reduced by 89 and 65%, respectively, by delaying rainfall from 2 to 5 d after dairy cattle slurry application. In addition, McDowell and Sharpley (2002a) found that flow path length had a significant effect on P fractions in runoff following land application of dairy swine slurry. Therefore, when examining the effect of changes in slurry management, these factors must be taken into consideration.

Rose (2004) considered the difference between the rate of detachment and the rate of sediment deposition to be responsible for the initial development of sediment runoff in surface water. As P is adsorbed to sediment (Torbert et al., 2002), the settling velocity of eroded soil particles is of critical importance. Smaller particles will take much longer to settle and have the potential to travel greater distances than larger particles in the same

conditions (Figure 2.7). The distance which these particles can travel is determined based on Stokes law (Batchelor, 1967).

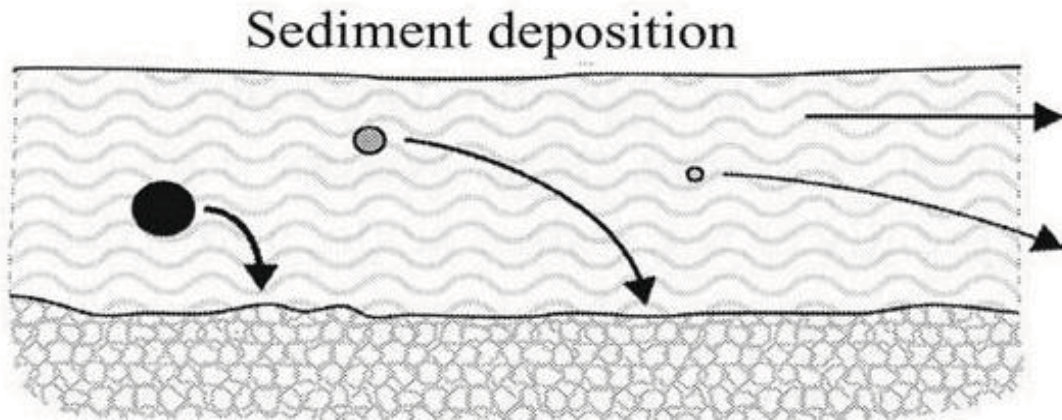

Figure 2.7 Rate of sediment deposition in surface runoff (Rose, 2004)

The gradual formation of a surface seal under prolonged rainfall and submergence may cause reduced infiltration rates into the soil and, consequently, may induce increased erosion in some soils. This phenomenon occurs when the impact of the falling rain damages the structure of the soil so that the permeability of the soil surface is reduced or when rain falls on damaged clay soils with very low permeability. This theory suggests that the soil particles are held together in bundles or aggregates. The action of the rain falling can break these bundles apart and, in some cases, may cause the pores on the soil surface to seal (Rose, 2004).

Detachment is the dominant process responsible for sediment erosion in the early stages of a rainfall event (Rose et al., 1983). As the runoff event increases in magnitude, the rainwater can no longer infiltrate the soil surface and overland flow occurs. This phenomenon is also known as capping or infiltration excess (Horton, 1933). Entrainment is the process which involves the surface runoff eroding the soil particles (Figure 2.8). The erosion processes for slurry are similar to soil.

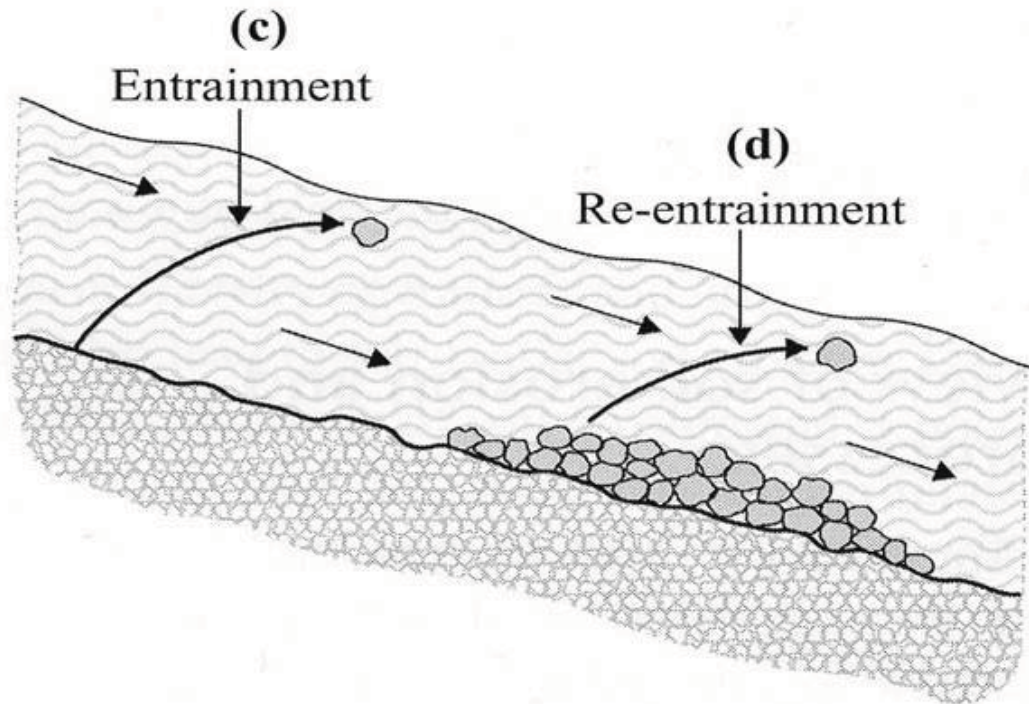

Figure 2.8 Entrainment and re-entrainment of sediment (Rose, 2004).

The ability of flowing water to erode sediment is related to the stream power, Ω , which is a function of shear stress and the velocity of the surface runoff (Rose, 2004). Once Ω exceeds a threshold value, Ω_0 , sediment is eroded. Detachment processes are less significant in deep surface flow. However, rain falling on shallow water will increase turbulence and liberate particles. Particles which are put into suspension after entrainment are then deposited according to their settling velocity. Over time, these particles accumulate and begin to rebuild the eroded soil surface. These particles have insufficient time to gain cohesive strength and are more easily eroded than the original deposited sediment. This erosion process is known as re-entrainment. Re-entrainment moves the particles in the general direction of flow by saltation (Figure 2.8). The processes by slurry particles are moved in surface water are similar.

2.10. Gaseous emissions and the importance of considering pollution swapping when selecting a P mitigation measure

Agricultural activities contribute to the production of NH_3 and GHG such as CO_2 , N_2O and CH_4 . In particular, land application of dairy slurry can result in the release of NH_3 (Amon et al., 2006), N_2O (Ellis et al., 1998), and CH_4 (Chadwick and Pain, 1997). It is critical that the potential for pollution swapping is examined when evaluating a potential technology. In particular, the effects of any proposed treatments on GHG emissions must be examined. Under the 1997 Kyoto Protocol of the United Nations Framework Convention on Climate Change (UN, 1998), participating nations agreed to publish national inventories of anthropogenic emissions of several GHG and to reduce future emissions below 1990 levels. In Ireland, agricultural activities were responsible for approximately 26% of total GHG emissions in 2008 (McGettigan et al., 2010) and account for virtually all NH_3 emissions, with animal manure alone responsible for 92% of NH_3 emissions (EPA, 2010). While NH_3 is not a GHG, it contributes to acidification of soils, atmospheric pollution, and the eutrophication of surface and ground water systems (Goulding et al., 1998). An estimated 5% of global N_2O emissions results from the conversion of NH_3 into N_2O in the atmosphere (Ferm, 1998).

2.11. Present and emerging P mitigation measures

The general consensus held by researchers in Ireland is that Ireland will not meet its water quality targets by 2015 (Schulte et al., 2010b; McGarrigle et al., 2011). This failure to achieve the required improvements in water quality status is a common problem being faced throughout Europe and in the US. It is largely accepted that supplementary measures, in particular the development of P mitigating technologies, will be critical to develop short-term farm management practices which will reduce nutrient losses to waterbodies (Buda et al., 2010). These mitigation methods, together with best management practices which are already in place, will enable the achievement of water quality requirements in shorter time period. This will allow for the development of long-term, sustainable management practices to minimise risk of P loss to water.

In Ireland, attempts to reduce diffuse P loss from agriculture have focused on increasing nutrient efficiency and improving slurry management strategies. To address the time lag between implementation of these strategies and reduction of STP to the boundary index 3 in high P-index farms (Table 2.6), short-term P mitigation technologies are required. Current guidelines state that farmers may only apply dairy cattle slurry to high STP soil in the absence of low STP soil. On such farms, treatment of dairy cattle may be considered for use in tandem with existing management practice to reduce the solubility of P during this ‘time lag’ period. Mitigation methods to reduce incidental P losses include incorporating slurry into soil immediately after land application (Tabbara, 2003), increasing length of buffer zones between slurry application areas and drains and streams (Mayer et al, 2006), enhanced buffers strips (Uusi-Kämpä et al., 2010), timing of slurry application (Hanrahan et al., 2009), chemical amendment (Dao and Daniel, 2002; Dou et al., 2003) and diet manipulation (O’Rourke et al., 2010). The risk of P loss from slurry is strongly related to the WEP in the slurry (Dou et al., 2003) and amendments which reduce P solubility should reduce P loss to runoff. In this section, current management practices, along with new technologies, to treat dairy cattle slurry and to mitigate P losses from land application of dairy cattle slurry are discussed.

2.11.1. Constructed wetlands

To date, free-water surface (FWS) Constructed Wetlands (CWs) (reed beds) are the most widely used, low-cost and low-maintenance alternative to land spreading of dairy wastewaters in Ireland. Constructed wetlands provide an environment for the physical/physico-chemical retention and biological reduction of organic matter (OM) and nutrients (Knight et al., 2000). Depending on the organic loading and retention time (Karpiscak et al., 1999), constructed wetlands can have a significant nutrient removal capacity. However, due to the effect of varying temperatures, the treatment efficiency of these systems tends to vary throughout the year (Healy and Cawley, 2002).

Constructed wetlands may be planted with plants found in natural wetlands and lined with soil to trap nutrients and solids from wastewaters. They may be used to treat runoff

from intensively farmed soils in close proximity to sensitive water bodies (Tanner et al., 2005), or alternatively, to treat wastewaters before water is land applied to reduce potential for pollution (Healy et al., 2007). There is a long history of use of CWs to treat municipal wastewaters and they have more recently been adopted to treat dairy waste water and screened dairy slurry (the liquid portion of dairy cattle slurry following separation) (Healy et al., 2007).

Guidelines for the design loading of surface-flow wetlands (Healy et al., 2007) recommend an area loading rate of approximately 5 g of 5-day biological oxygen demand (BOD₅) m⁻²d⁻¹. Although CWs have been shown to be very effective achieving good reductions in municipal and dilute dairy waste waters (soiled dairy water etc), the high solids content and the high nutrient concentrations of agricultural slurries make them difficult to treat. New Zealand guidelines for the disposal of farm dairy wastewaters (Tanner and Kloosterman, 1997) recommended that an FWS CWs should only succeed two waste stabilization ponds (an anaerobic and an aerobic pond, respectively) before entering the wetland with an organic loading rate not exceeding 3 g BOD₅ m⁻² d⁻¹. The anaerobic pond reduces the BOD₅ and SS, and the aerobic pond carries out further biological reductions. Mantovi et al. (2003) suggests that the milking parlour should be designed to allow parlour washings and washings from the holding room to be separated, so as the wetland only treats the effluent of lower organic and nutrient content.

The removal of NH₄-N from strong waste waters is generally inadequate in most CWs (Sun et al., 2005; Toet et al., 2005). Inorganic nitrogen removal is also often unsatisfactory (Luederitz et al., 2001) and in Europe, average percentage removal of NH₄-N during long-term operation is approximately 35%, with a maximum of 50% (Verhoeven and Meuleman, 1999).

The ability of CWs to retain P is dependent on the P loading rate, the media type, vegetation, and duration of operation (Healy et al., 2007), although changes in pH and redox potential could also release P from the system. Healy et al. (2007) reported that between 65 and 95% of P may be removed at loading rates of less than 5 g TP m⁻² yr⁻¹.

Phosphorus is removed through short-term or long-term storage, with most removal often occurring near the inlet initially, before extending throughout the wetland over time as those sites become P-saturated (Jamieson et al., 2002). Uptake by bacteria, algae and duckweed (*Lemna spp.*), and macrophytes provides an initial removal mechanism. However, this is only a short-term P storage as 35 to 75% of P stored is eventually released back into the water upon dieback of algae and microbes, as well as plant residues. The only long-term P storage in the wetland is via peat accumulation and substrate fixation, the efficiency of which is a function of the loading rate and the amount of native iron (Fe), Ca, Al, and OM in the substrate. Henry et al. (2003) reported reductions of total dissolved solids (TDS), NH₄-N, TN, and TP were 58%, 83%, 90%, and 84%, respectively, in the first 3 years of operation. These were above the national averages for CWs. However, these results indicate that CWs can be effective when properly managed. Although there is much evidence to support use of CWs, the P mitigating processes and long-term viability of CWs for P control are not sufficiently understood to pursue CWs as a potential management decision to control short-term P surplus. They also perform poorly when it is raining and are susceptible to incidental P loss during storm events.

2.11.2. Anaerobic digestion

Digestion of organic wastes results in the production of slurry with lower pollution potential and which is more suitable for use as a fertiliser while producing renewable energy (Singh et al., 2010a). Anaerobic digestion (AD) is now seen as the best manure management practice, as it offers the opportunity to reduce gaseous emissions from manure, increase N availability, produce biogas and reduce GHG emissions (Holm-Nielsen et al., 2009; Masse et al., 2011). Although AD reduces WEP of slurry without reducing plant availability of P (Moller and Stinner, 2009), the main benefit of AD in terms of P mitigation is that the digested slurry can be separated and the solid fraction exported off-farm for use as a soil conditioner, or further processed into a granular organic fertiliser, or a combustible fuel which has a commercial value. Anaerobic digestion reduces gaseous losses from slurry (Amon et al., 2006; Clemens et al., 2006)

and increases N availability in slurry (Moller et al., 2008). Amon et al. (2006) reported that AD reduced N₂O losses from dairy cattle slurry by approximately 28% compared to a slurry-control. Anon et al. (2006) also reported that CH₄ losses following land application of digested dairy cattle are lower and there are no adverse effects on NH₃ emissions compared to untreated dairy cattle slurry (Amon et al., 2006; Clemens et al., 2006). In addition, AD can lower the odour from farm slurries by up to 80% (Pain et al., 1990), lower survival of pathogens in the slurry (Masse et al, 2010; Cote et al., 2006), and kill many weed seeds, reducing need for herbicides (Frost and Gilkinson, 2010). There are extensive AD plants in mainland Europe; however, there are only pilot-scale plants in Ireland (Anon, 2011). Although AD is not currently considered a P management option, Gungor and Karthikeyan (2008) reported that AD decreases water soluble P fraction by between 22 and 47% compared to undigested slurry.

Although the advantages of AD are immense, there are some difficulties which have restricted their adoption in Ireland. The main barriers to their use are the high capital cost necessary to establish them, the low dry matter (DM) content of slurry on many dairy farms, the energy requirement to maintain temperatures sufficient for the digester to operate, and a long hydraulic retention time. This means that a large AD reactor is necessary for high volumes of slurry (Frost and Gilkinson, 2010). Moller et al. (2007) examined the feasibility of separating slurry prior to AD and recommended that pre-separation may increase yield, but the feasibility depends on the cost of separation and transportation of slurry from farm to AD plant. Although AD is the most environmentally sustainable means of treating slurry in the long-term, it is unlikely that AD can be implemented specifically to mitigate P losses in sufficient time to meet requirements of the WFD. Many German farmers make a living producing biogas from such operations; however, their government provides financial supports for such enterprise (Anon, 2011). In the long-term, with improvements in technology and with the support of government initiatives, AD may become a management practice in Ireland.

2.11.3. Biochar

Biochar is produced when biomass is burnt in the absence of oxygen at temperatures <700°C (Lehmann and Joseph, 2009). There is growing acceptance that biochar may play a part in reducing GHG emissions from agriculture (Winsley, 2007). There are two biochar P mitigation management systems currently being examined for the treatment of dairy cattle slurry: (1) slurry can undergo pyrolysis and be converted to a biochar, which can be applied to soils as a soil conditioner and fertiliser and to reduce losses of metals from soils (Cao and Harris, 2010) and (2) biochar produced from another biomass source can be used to sequester P and then land applied in another location (Streubel et al., 2010).

These technologies have the potential for use as part of sustainable manure management to allow transport of biochar produced from slurry, or biochar enriched with nutrients, to soils with low STP. Biochar has a much lower volume than slurry used to produce it and would be much more attractive as a fertiliser and soil conditioner to a wide range of uses not limited to agriculture. Land application of biochar can restore fertility in degraded soils (Novak et al., 2010), improve health of the soil (O'Neill et al., 2009; Van Zwieten et al., 2010), reduce nutrient leaching (Singh et al., 2010b), reduce GHG losses (Gaunt and Lehmann, 2008; Rogovska et al., 2011) and improve fertiliser efficiency in some soils (Van Zwieten et al., 2010).

Streubel et al. (2010) investigated the potential for using biochar produced from pyrolysis of AD sludge to sequester P from dairy lagoons and found that 50% reduction of soluble P in dairy slurry lagoon was achieved while the plant available P in the biochar increased from 4 to 45 mg kg⁻¹ Olsen P. This system allows the nutrients to be trapped and transported to areas with low P soil where they can be used a soil conditioner and fertiliser. Although there is excellent potential for GHG emission reduction (Gaunt and Lehmann, 2008) and potential to reduce P loss from agriculture by transporting saleable product from areas with P surplus, this technology is not developed sufficiently for widespread implementation. There are high capital costs and these systems would need to

be validated at farm-scale before being recommended for use in Ireland. The low DM of dairy cattle slurry results in a very high cost of drying slurry and this is one of the main barriers to the production of biochar from slurry (Xinmin Zhan *pers com*, 2011). Systems using biochar to sorb P from slurry lagoons are not as likely to be attractive to farmers in Europe as in the U.S.A., as slurry lagoons are not as common in Europe. In addition, the risk of pollution swapping associated with slurry lagoons is a problem. The main barrier to use of biochar technology is that there is no legislation in place regarding of biochar for use by agriculture and before biochar can be used as an amendment for soils, standards need to be established (Kwapinski et al., 2010).

2.11.4. Buffer strips and enhanced buffer strips

Buffer strips have been implemented to reduce P losses from waters entering waterways (Hoffmann et al., 2009). Buffer-strips are particularly effective at reducing PP and current best farming practice stipulates a 2.5 m buffer-strip between edges of slurry application and a stream or drain. This is a natural buffer-strip which acts to reduce risk of P loss to surface waters. Studies have reported conflicting results (Table 2.7). The consensus is that buffer-strips are not very effective at trapping DRP (Watts and Torbert, 2009) and are generally more effective in reducing PP losses (Hoffmann et al., 2009). They are a cost effective TP and PP mitigation method and offer an attractive means of treating runoff from high STP soils. However, they are not always effective in storm events.

Many researchers have examined the potential to enhance DRP sorbing potential of buffer strips using amendments (Dayton and Basta, 2005; Uusi-Kämpä et al., 2010). Uusi-Kämpä et al. (2010) examined the potential for use of amendments in buffer strips to increase P retention and found that, while gypsum and CaCO₃ did not change DRP and TP loss to runoff during simulated runoff events, Fe-gypsum and granulated ferric sulphate increased DRP and TP retention between 74-85 and 47 to 64%, respectively. Dayton and Basta (2005) enhanced a buffer strip down-slope of soil receiving poultry litter using WTRs (20 Mg ha⁻¹ WTR). This resulted in a reduction in DRP in runoff by between 67 and 86% compared to the buffer strip without any WTR incorporated. Watts

and Torbert (2009) applied gypsum at 0, 1, 3.2 and 5.6 Mg ha⁻¹ to a 1.52 m-wide buffer-strip down-slope of a soil receiving poultry litter. The unamended buffer-strip reduced DRP loss by 18%. This increased to 32-40% for all gypsum amended buffer-strips with the rate of gypsum applied having no significant effect.

Table 2.7 Performance of buffer strips in reducing total and soluble phosphorus in runoff (adapted from Kay et al., 2009)

Pollutant	Reduction	Reference
Total phosphorus	6% reduction	McKergow et al. (2003)
	10 to 98% reduction	Heathwaite et al. (1998)
	0 to 97% reduction	Uusi-Kämppeä et al. (2000)
	31% reduction	Abu-Zreig. (2001)
	8 to 97% reduction	Dorioz et al. (2006)
	27% decrease to 41% increase	Borin et al. (2005)
Soluble phosphorus	16% reduction	Vaananen et al. (2006)
	61% increase	McKergow et al. (2003)
	17% decrease–475% increase	Borin et al. (2005)
	0 to 30% decrease	Dorioz et al. (2006)

Although these systems mainly use waste products (such as WTR, FGD, etc), they would be unfeasible on a large-scale due to availability of the waste products and cost of installing systems on a large-scale. Therefore, these P mitigation technologies are recommended for use in CSA; areas where pollution due to runoff or leaching is likely to occur) only.

2.11.5. Composting

Aerobic composting of organic waste is a very effective method of stabilising and sterilising waste materials. Composting manure reduces water content and reduces pathogen survival, kills weed seeds, and is easier to land apply (Eghball and Gilley, 1999). Slurry must be separated before it can be composted and this is the major barrier to their widespread use. Miller et al. (2006) reported that land application of composted cattle manure, rather than fresh cattle manure, may be a potential management tool to

control P and N in surface water. Although composting does not sequester P, it converts the manure from a high water content, low nutrient concentration odorous material to a low water content, soil-like material, which is rich in nutrients and can be transported long distances and be used by farmers, or sold to other industries and households as a fertiliser. While composting manure reduces GHG emissions effectively (Pattey et al., 2005), it can cause increases in NH₃ emissions (Parkinson et al., 2004).

2.11.6. In-stream and edge of field filters

The alternative to reducing P lost to runoff is to recover P from drainage waters. In-stream and edge-of-field filters have been examined by many researchers throughout the world (Shipitalo et al., 2010a; McDowell et al., 2008; Bryant et al, 2010; Uusi-Kämppe et al., 2010). Remediation techniques which treat water in-stream include filter socks (Shipitalo et al., 2010a), backfilling tile-drains with P sorbing material (McDowell et al., 2008); various reactive barriers placed along field drains and drainage ways (Bryant et al., 2010; Uusi-Kämppe et al., 2010), reactive materials placed in sub-surface drains (Penn and McGrath, 2011) and ferric sulphate dispensing units (Narvanen et al., 2008).

Shipitalo et al. (2010a) found that compost-filled socks (Figure 2.9) were ineffective in reducing P loss from a grassland catchment. In a subsequent study, Shipitalo et al. (2010b) amended the compost with a nutrient sorbent to improve nutrient retention. This resulted in a 27% reduction in DRP in drain water after passing through the filter sock.

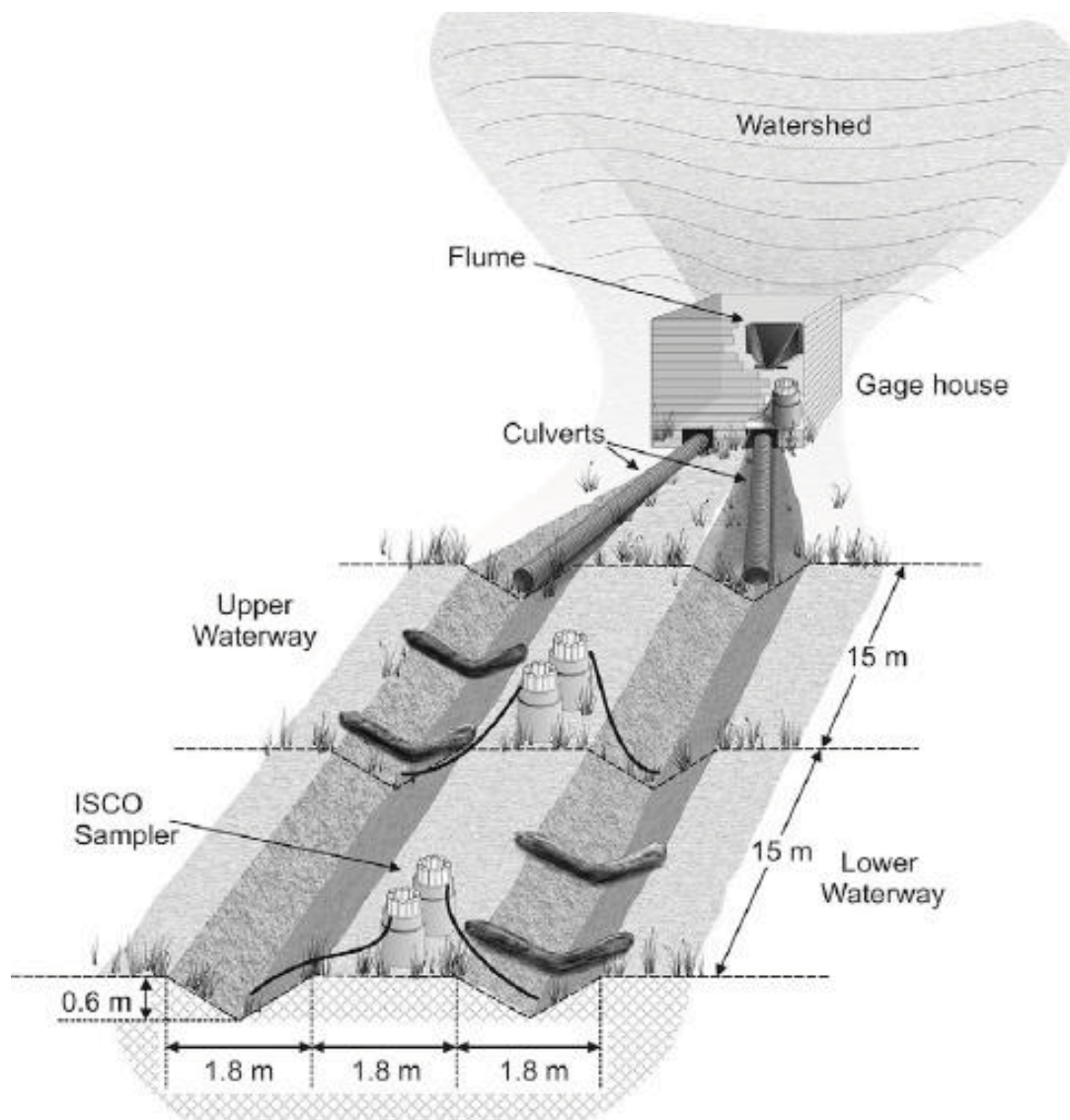

Figure 2.9 Compost filled socks in instrumented drainage channel (Shipitalo et al., 2010a)

Compost socks are not the most effective P sorbing systems. The initial aim of compost filter socks was to prevent SS loss and as the focus has shifted to P loss, researchers have examined more effective P sorbing materials. McDowell et al. (2008) examined the potential for use of industrial by-products to reduce P loss from tiled drained land. In this study, backfilling tile drains with a mixture of 90% melter slag and 10% basic slag

reduced DRP and TP from 0.33 mg DRP L⁻¹ and 1.20 mg TP L⁻¹ for control to 0.09 mg DRP L⁻¹ and 0.36 mg TP L⁻¹.

Bryant et al. (2010) used a permeable FGD gypsum barrier to intersect ditch water and to precipitate soluble P as calcium phosphate. Between 35 to 90 % of the P from ditch flow that passed through the filter was removed. However, during large flow events, the water flowed over the barrier and this was identified as the main problem associated with such P mitigation systems. Figure 2.10 shows the general layout of such edge of field filters.

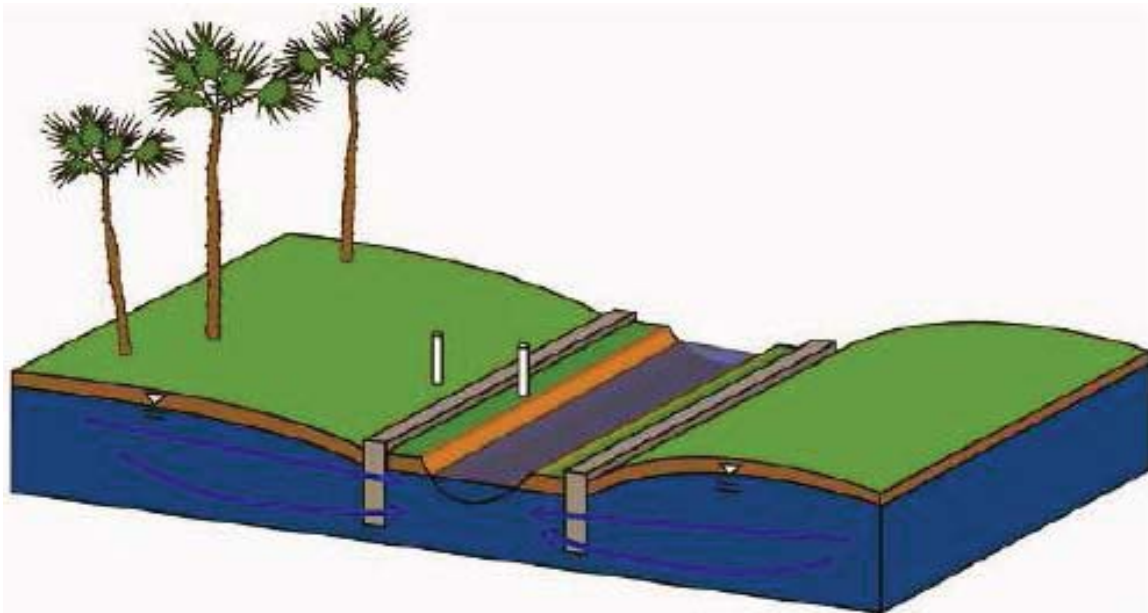

Figure 2.10 Permeable edge of field barriers (O'Connor et al., 2010)

The ideal situation would be to use materials which can be replenished. Penn and McGrath (2011) examined the ability of steel slag and a surface-modified slag to sorb P in golf course runoff in a flow-through system, and found that both treatments reduced DRP by approximately 31% with the need to replenish slag when it becomes saturated with P. Narvanen et al. (2008) designed a ferric-sulphate doser to treat runoff from a CSA (Figure 2.11). Immediately following chemical treatment, water was passed through a settling pond and then filtered in a sand bed. This system resulted in reductions in DRP and TP in runoff from CSA of 95 and 81%.



Figure 2.11 Schematic and photo of ferric-sulphate doser in operation in Jokioinen, Finland (Narvanen et al., 2008)

2.11.7. Sand and woodchip filter systems

Researchers have examined the use of sand (Healy et al. 2004) and woodchip filters (Ruane et al., 2011) to treat dairy soiled water. Recently, Carney et al (2011) have examined the effectiveness of wood chip filters in treating the liquid portion of pig slurry following separation (Figure 2.12). There is potential that such systems could be used to treat the liquid portion of dairy cattle slurry following separation. While sand and woodchip filters have been shown to significantly reduce BOD₅ and N losses (Healy et al., 2004; Ruane et al., 2011; Carney et al., 2011), they do not reduce P concentrations sufficiently to allow release of wastewaters to waterways.

The performance of filters depends on composition of influent and any filter system would require maintenance and constant monitoring to ensure that system was performing properly. While further steps could be included at subsequent stages of treatment to remove P, these systems would require further capital investment.

2.11.8. Slurry separation

The objective of slurry separation is to split the slurry into a liquid with low solids content and a solid with high DM. There are three main types of separator: brushed screen separator, decanting separator and screw-press separator. Gilkinson and Frost

(2007) carried out a comprehensive study of the brushed screen separator and decanting separator, and found that there was a strong correlation between DM and TP in slurry. Their report concluded that mechanical separation may be an option for farmers with a P and N surplus on farm. Slurry separation requires a significant initial investment and this is likely to be the biggest barrier to implementation. Slurry separation is the first step in treatment as the solid portion of the slurry must be further treated and liquid land applied.



Figure 2.12 Pilot scale wood chip filter used to treat the liquid portion of pig slurry following separation (Carney et al., 2011)

There has been extensive research into separation of slurry in the US. Currently, approximately 1-2% of dairy farmers in the US use polymers with a flocculent such $AlCl_3$ to help with solids separation (Philip Moore *pers com*, 2010). Such systems are very effective in reducing TP and soluble P in the liquid portion of separated slurry (Powers et al., 1995; Barrow et al., 1997; Krumpelman et al., 2005). This liquid portion can be land applied on farm to meet N requirements and the solid portion, which is high in P, can be transported off-farm. A summary of reductions of WEP and TP in slurry shown in Table 2.8.

Table 2.8 Review of laboratory-scale studies examining chemical aided separation to reduce P in liquid fraction of separated dairy cattle slurry

Reference	Chemical added	TP %	SS %
Powers et al. (1995)	[0.75g CaCO ₃ + 0.5 ml Fe ₂ (SO ₄) ₃] L ⁻¹	54	
	[0.75g CaO + 0.5 ml Fe ₂ (SO ₄) ₃] L ⁻¹	93	
	[0.5 ml Fe ₂ (SO ₄) ₃ + 5 drops polymer] L ⁻¹	62	
Krumpelman et al. (2005)	804 mg Fe L ⁻¹ + 150 ml 225G-PAM	74	54
	384 mg Al L ⁻¹ + 100 ml 225G-PAM	77	67
Barrow et al. (1997)	278 mg Fe L ⁻¹ as FeCl ₃	88	89
	358 mg Ca L ⁻¹ as CaO	92	93

2.11.9. Use of P sorbing amendments

Fenton et al. (2008) recommended the addition of amendments to dairy cattle slurry prior to land spreading as a management practice to reduce P losses arising from land application of dairy cattle slurry Ireland. In the U.S.A., chemical amendment of poultry litter has been proven to be effective in reducing P losses from poultry litter and has been used as best management practice for over 30 years (Moore and Edwards, 2005). There has been limited work involving chemical amendment of dairy manure (Dao, 1999; Dou et al., 2003; Kalbasi and Karthikeyan, 2004), however, much more work is needed before chemical amendment can be recommended for implementation as a management practice in Ireland. Phosphorus sorbing amendments can be incorporated into soil to reduce soluble P in soils with high STP (Anderson et al, 1995; Novak and Watts, 2005); or, for incidental losses, added directly to the manure before land application to control P in manure being applied (Moore et al., 1999), or applied after manure application to reduce P losses from applied manure (Torbert et al, 2005).

2.11.9.1. Amendments applied directly to soil

Addition of chemical amendments to soils has been shown to reduce P solubility in high P soils and thus the potential to reduce the risk of P loss to waterbodies in surface runoff. Anderson et al. (1995) amended soils with a history of receiving dairy manure in an

incubation experiment with calcium carbonate (with the slurry pH adjusted to 7.5), gypsum (0 to 100 g kg⁻¹ soil), ferrous sulphate (0 to 1 g kg⁻¹ as Fe) and alum (0 to 1 g kg⁻¹ as Al). Calcium carbonate effectiveness was limited to soils with pH < 7.0 and gypsum was effective over a broad range of manure loading, pH and redox conditions. Although Al and Fe amendments to soil increased P retention by 400% relative to an unamended control, the authors acknowledged elevated costs associated with amendments and potential biological toxicity. In a laboratory incubation study, Novak and Watts (2005) incorporated an alum-based WTR into three soils with a Mehlich-3 P (M3) of between 145 mg kg⁻¹ and 371 mg kg⁻¹, and found that the amendment reduced WEP in the soil by between 45% and 91% after an 84-d incubation period. They also found that WTR was efficient at reducing M3 of soils with a M3 of between 145 and 235 mg kg⁻¹, but not soil with a M3 of 371 mg kg⁻¹ soil. Stout et al. (1998) amended soil with flyash at 0.01 kg kg⁻¹ soil in a laboratory incubation experiment, and found that M3 and WEP were lowered by 13% and 71%, respectively. Flue gas desulphurisation by-product, applied at 0.01 kg kg⁻¹ soil, lowered M3 by 8% and WEP by 48%. Table 2.9 shows chemical amendments studies with manure type, study type and percentage reductions in WEP of slurry and slurry amended soil.

2.11.9.2. Amendments to slurry

The present study examines for the first time the effect of chemical amendment of dairy cattle slurry on P, N and metal (namely Al, Fe and Ca) losses to runoff, whereas most previous studies only examined the effect of amendments on P solubility (Dao, 1999; Dao and Daniel, 2002; Dou et al., 2003). Dou et al. (2003) found that technical grade alum, added at 0.1 kg kg⁻¹ (kg alum per kg slurry) and 0.25 kg kg⁻¹, reduced WEP in swine and dairy slurry by 80% and 99%, respectively. Dao (1999) amended farm yard manure with caliche, alum and flyash in an incubation experiment, and reported WEP reductions in amended manure compared to the control of 21, 60 and 85%, respectively. Kalbasi and Karthikeyan (2004) applied untreated and amended dairy slurry to a soil and incubated it for 2 years; alum and FeCl₂ were observed to decrease P solubility, while lime amendments increased WEP.

Table 2.9 Results of laboratory and plot-scale chemical amendments studies to date

Reference	Chemical	Rate	Manure type	Study type	% soluble P reduction in:		
					Runoff	WEP _{waste}	WEP _{soil+waste}
Dao (1999)	Alum	0.1 kg kg ⁻¹	Cattle stockpiled	Laboratory			60
		0.1 kg kg ⁻¹	Cattle composted				83
	Caliche	0.1 kg kg ⁻¹	Cattle stockpiled	Laboratory			21
		0.1 kg kg ⁻¹	Cattle composted				50
	Flyash	0.1 kg kg ⁻¹	Cattle stockpiled	Laboratory			85
		0.1 kg kg ⁻¹	Cattle composted				93
Dao and Daniel (2002)	Alum	0.01 kg kg ⁻¹	Dairy slurry	Laboratory		66	63
	FeCl ₃	0.01 kg kg ⁻¹	Dairy slurry	Laboratory			18
	Flyash	0.01 kg kg ⁻¹	Dairy slurry	Laboratory		44	82
Dou et al. (2003)	Alum	0.1 kg kg ⁻¹	Dairy	Laboratory		99	
	Flyash	400 g kg ⁻¹	Dairy			50-60	
	FGD	400 g kg ⁻¹	Dairy			50-60	
Lefcourt and Meisinger (2001)	Alum	0.4% (w/w)	Dairy slurry	Laboratory		75	
		2.5% (w/w)				97	
McFarland et al. (2003)	Alum	0.78 kg m ⁻²	Dairy effluent	Plot			90
	Gypsum	0.78 kg m ⁻²	Dairy effluent	Plot	52		
Meisinger et al. (2001)	Alum	6.25% (w/w)	Dairy slurry	Laboratory			
Novak and Watts (2005)	Al-WTR	1-6% (v/v)	None	Incubation			45-91
Smith et al. (2001a)	Alum	215 mg Al L ⁻¹	Swine	Plot		33	
		430 mg Al L ⁻¹				84	
	AlCl ₃	215 mg Al L ⁻¹			45		
		430 mg Al L ⁻¹			84		
Stout et al. (1998)	Flyash	0.01 kg kg ⁻¹	None	Laboratory			71
	FGD						48
Zhang et al. (2004)	Flyash	0.4 kg kg ⁻¹	Dairy manure	Laboratory		50-60	
Fenton et al. (2009)	Ochre	50 g L ⁻¹	Dairy effluent	Laboratory		99	
Torbert et al (2005)	Lime	3:1 metal to P	Dairy slurry		0		
	Gypsum	3:1 metal to P			0		
	FeSO ₄	3:1 metal to P			66		

A limited number of runoff studies have been carried out with chemical amendment of dairy cattle slurry (Elliot et al, 2005; Torbert et al, 2005) and swine slurry (Smith et al, 2001a). Torbert et al. (2005) amended landspread composted dairy manure with lime (3:1 metal-to-TP ratio) immediately prior to a 40-min rainfall event (overland flow equivalent to a rainfall intensity of 12.4 cm h⁻¹). Lime amendments increased DRP loss. In a plot study, Smith et al. (2001a) amended swine manure with alum and AlCl₃ at two stoichiometric ratios (0.5:1 and 1:1 Al: TP). Dissolved reactive phosphorus reductions for

alum and AlCl_3 at the lower ratio were 33% and 45%, respectively, with 84% for both amendments at the higher ratio.

Chemical amendments of slurry using Al, Fe, or Ca based compounds reduce P solubility in manure (Dao, 1999; Dou et al., 2003; Kalbasi and Karthikeyan, 2004) and reduce P in runoff from plots receiving alum amended poultry litter (Moore and Edwards, 2005) with negligible effect on metal loss (McFarland et al., 2003). Chemical amendments reduce incidental P losses by a combination of the formation of stable metal-phosphorus precipitates (such as Al-P phosphates in the case of alum) and flocculation of the particles in the slurry to form larger particles, which are less prone to erosion (Tchobanoglous et al., 2003). Previous studies have found that there was no risk of increased metal release posed by chemical amendment of poultry litter (Moore et al., 1998), dirty water (McFarland et al., 2003), or horse manure (Edwards et al., 1999).

2.12. Recommendations and knowledge gaps

In Ireland, point source pollution caused by agriculture has been overcome by infrastructural investment on farms and by the removal of point sources in catchments. Attempts to reduce diffuse P loss from agriculture have focused on increasing nutrient efficiency and improving slurry management strategies. In order to meet our water quality obligations, it is becoming apparent that (1) the efficacy of the Nitrates Directive (Ireland's agricultural POM) will need time to be assessed and (2) further investigation of mitigation measures (supplementary measures within the WFD), such as those outlined within the EU COST 869 project (coming to a conclusion in October 2011), will be necessary.

This review has identified a need for a short-term, cost effective management practice, which can be implemented to reduce the solubility of P in slurry and reduce the risk of incidental and chronic P losses. It is critical that the P mitigation measure selected can mitigate both of these losses. In the long-term, it is likely that a wide range of these technologies will be harnessed in parallel with land application of slurry.

In the short-term, however any P mitigation measure must have the ability to be quickly implemented within the existing farm slurry management structure, be cost effective and capable of being used in strategic locations for maximum effect. Chemical amendment of dairy cattle slurry was chosen for further investigation in the present study. Specifically, there have been limited studies involving chemical amendment of dairy cattle slurry and such studies have not considered the feasibility of using amendments at farm-scale, or the changes to the hydrology of a system through their use, pollution swapping and the long-term effects on STP. This is the first study to examine a range of potential chemical amendments for mitigation of P losses from dairy cattle slurry in Ireland.

The following knowledge gaps were identified in the present review:

1. There have been no studies conducted to evaluate the effectiveness and feasibility of potential chemical amendments in Ireland. There is a need for such a study if amendments are to be considered for implementation in Ireland.
2. There is a need for a study to examine the effect of chemical amendment of dairy cattle slurry on metal loss to runoff.
3. The effect of chemical amendment of dairy cattle slurry on pollution swapping, in particular N loss to runoff and GHG emissions, needs to be examined
4. The effect of chemical amendment of dairy cattle slurry prior to application to soil on long-term soil WEP and STP.
5. To examine the effect of soil type on the solubility of P in soil following application of amended slurry to soil.
6. To investigate the role chemical amendments may have in mitigation of P losses from dairy cattle slurry in Ireland.
7. To examine conditions in which they work and discuss limitations in use.

Chapter 3 Evaluation of chemical amendments to control phosphorus losses from dairy slurry

3.1. Overview

Land application of dairy slurry can result in incidental losses of P to runoff in addition to increased loss of P from soil as a result of a build up in STP. A novel agitator test was used to identify the most effective amendments to reduce DRP loss from the soil surface after land application of chemically amended dairy cattle slurry.

3.2. Introduction

Batch experiments, although allowing quick determination of adsorption capacities of amendments, are unrealistic when considering nutrient losses in runoff following manure application. These small-scale tests do not account for the interaction between applied slurry and soil, and the effect of infiltration and skin formation on the release of P to surface runoff. An ‘agitator test’, wherein an intact soil core, placed in a beaker, is overlain with continuously-stirred water (Mulqueen et al., 2004), enables achievement of batch experiment results, but also simulates the situation in which slurry is applied to soil, allowed to dry, and then subjected to overland flow (Figure 3.1). The test provides standardised conditions for assessment of the effectiveness of various amendments to slurry at reducing the release of P that may relate to land-applied slurry.

The objectives of this study were to: (1) use a laboratory agitator test to identify the most effective chemical amendments to reduce P loss from the soil surface after land application of amended dairy cattle slurry (2) identify optimum amendment application

rates for a similar P reduction in different amendments (3) estimate the cost of each treatment, and (4) discuss the feasibility of using treatments in a real on-farm scenario.



Figure 3.1 Beakers placed in flocculator during agitator test

3.3. Materials and methods

3.3.1. Soil preparation and analysis

Soil samples were collected from a dry stock farm (53°21' N, 8°34' W) in Galway, Republic of Ireland. 120-mm-high, 100-mm-diameter Al coring rings were used to collect undisturbed soil core samples.

Soil samples (n=3) – taken from upper 100 mm from the same location - were air dried at 40 °C for 72 h, crushed to pass a 2 mm sieve and analysed for P using M3 extracting solution (Mehlich, 1984) and Morgan's P using Morgan's extracting solution (Morgan

1941). Soil pH (n=3) was determined using a pH probe and a 2:1 ratio of deionised water-to-soil. Shoemaker-McLean-Pratt (SMP) buffer pH was determined and the lime requirement (LR) of the soil was calculated after Pratt and Blair (1963). The particle size distribution (PSD) was determined using a sieving and pipette method (B.S.1377-2; BSI, 1990a) and the organic content of the soil was determined using the loss of ignition test (B.S.1377-3; BSI, 1990b). The soil used was a poorly-drained, silty loam topsoil, with 15% sand, 72% silt, 13% clay, and an OM content of $16.2 \pm 0.2\%$. The soil texture was classified using the US Department of Agriculture (USDA) soil texture triangle (Figure 3.2). The soil had a M3 concentration of $50 \pm 2.8 \text{ mg P kg}^{-1}$ dry soil, Morgan's P of $4.6 \pm 0.49 \text{ mg L}^{-1}$ (Index 2) and a soil pH of 5.6 ± 0.1 . The soil SMP buffer pH was 6.1 ± 0.2 and the LR was $9.9 \pm 1 \text{ t ha}^{-1}$.

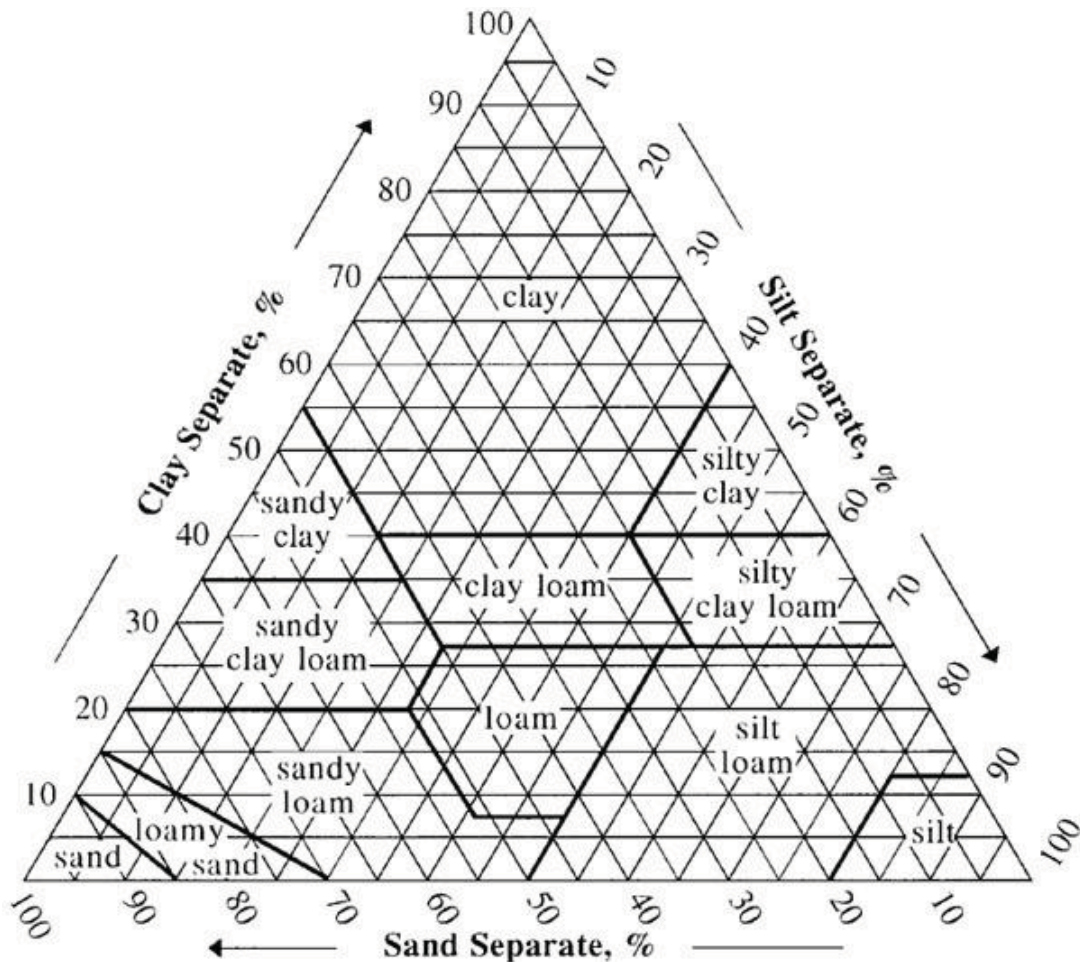

Figure 3.2 United States Department of Agriculture (USDA) soil texture classification triangle used to determine soil texture

3.3.2. Slurry sampling and analysis

Cattle slurry from dairy replacement heifers was taken from a dairy farm (53°18' N, 8°47' W) in Galway, Republic of Ireland. The storage tanks were agitated and slurry samples were transported to the laboratory in 10 Litre drums. Slurry samples were stored at 4°C. Slurry pH was determined using a pH probe (WTW, Germany) at 0 h and 24 h; the latter time corresponded with the time the slurry was interacting with the soil in the beaker before being saturated with water. The WEP of slurry was measured at 24 h as suggested by Kleinman et al. (2007). The TP of the dairy cattle slurry was determined after Byrne (1979). Potassium and magnesium (Mg) were analyzed using a Varian Spectra 400 Atomic Absorption instrument, and analyses for N and P were carried out colorimetrically using an automatic flow-through unit. The slurry had a TN concentration of $3982 \pm 274 \text{ mg L}^{-1}$, TP of $811 \pm 37 \text{ mg L}^{-1}$, total K (TK) of $4009 \pm 482 \text{ mg L}^{-1}$, and a pH of 7.3 ± 0.5 .

3.3.3. PSM sourcing and analysis

The Al-WTR was provided by Galway City water treatment plant (53°17' N, 9°03' W). Coal combustion by-products were provided by the Electricity Supply Board. The pH of the PSM was measured using 2:1 deionised water: dry amendment ratio. It was possible to measure the pH of the Al-WTR sludge with a pH probe. Dry matter content was determined by drying at 40°C for 72 h. Total metal and P of the PSM was measured by 'aqua regia' digestion using a Gerhard Block digestion system (Cottenie and Kiekens, 1984), which is described by Fenton et al. (2009). The WEP of the PSM was determined after Dayton and Basta (2001).

The characteristics of all Al-WTR-1, Al-WTR-2, flyash and FGD are presented in Table 3.1. Al-WTR-1 and Al-WTR-2 had respective Al contents of 11.1% and 5.3% (Table 3.1). Flyash contained 5.6% Al, 4.9% Ca, 2.5% Fe, 12,200 mg kg⁻¹ Mg and 5,460 mg kg⁻¹ TP. FGD contained 20% Ca, 2,950 mg kg⁻¹ Mg and trace amounts of Fe (0.1%) and Al (0.1%). The composition of the commercial grade alum used is also shown. Analytical

grade aluminium chloride (13% Al), ferrous chloride (18% Fe) and lime (54% Ca) were used in the experiment.

3.3.4. Agitator test

The agitator test comprised 10 different treatments: a grassed sod-only treatment; grassed sod receiving dairy cattle slurry at a rate equivalent to 40 kg TP ha⁻¹ (the study control), and grassed soil receiving 8 different chemically-treated slurries (Table 3.2) applied at a rate equivalent to 40 kg TP ha⁻¹. Amendments were added to slurry in a beaker and mixed for 10 min using a jar test flocculator set at 100 rpm. Each of the 8 amendments were applied at 3 different rates (high, medium and low) in triplicate (n=3). All agitator tests were carried out within 21 d of sample collection. These rates were based results of batch test (Appendix B).

Prior to the start of the agitator test, the intact soil samples - at approximately field capacity - were cut to approximately 45 mm depth and transferred from the sampling cores into beakers. This depth of soil in the beakers was considered sufficient to include the full depth of influence on release of P to overland flow (Mulqueen et al., 2004). The chemically-amended slurry was applied to the soil with a spatula (t=0 h), and was then allowed to interact for 24 h prior to saturation of the sample. After 24 h (t=24 h), samples were saturated by gently adding deionised water to the soil sample at intermittent time intervals until water pooled on the soil surface (over 24 h). Immediately after saturation was complete (t=48 h), 500 ml of deionised water was added to the beaker. The agitator paddle was then lowered to mid-depth in the overlying water and rotated at 20 rpm for 24 h, as an attempt to (Figure 3.3).

Table 3.1 Characterisation of PSMs and alum used in the agitator test (mean \pm standard deviation) tests carried out in triplicate

Amendment		Al-WTR-1	Al-WTR-2	Flyash	FGD	Alum
		(2 mm)	(sludge)			(Al ₂ (SO ₄) ₃ nH ₂ O)
pH		7.9 \pm 0.1	6.9 \pm 0.2	11.2 \pm 0.04	8.6 \pm 0.0	1.25
WEP	mg kg ⁻¹	<0.01		<0.01	<0.01	0
Al		11 \pm 0.0	5.3 \pm 0.2	5.7 \pm 0.2	0.1 \pm 0.0	4.23
Ca	%	1.3 \pm 0.1	0.11	4.9 \pm 0.2	20 \pm 0.3	
Fe		0.2 \pm 0.0	0.01	2.2 \pm 0.1	0.1 \pm 0.0	<0.01
K		0.03 \pm 0.0	<0.01	0.1	0.03	
As		6.2 \pm 1.1	<0.01	13 \pm 0.6	<0.01	1
Cd		0.16 \pm 0.0	<0.01	0.6 \pm 0.0	0.2 \pm 0.02	0.21
Co		0.5 \pm 0.3	<0.01	33 \pm 1	0.3 \pm 0.1	
Cr		3.8 \pm 0.21	0.3 \pm 0.02	88 \pm 2	3 \pm 0.1	2.1
Cu	mg kg ⁻¹	31.7 \pm 1.5	0.6 \pm 0.03	32.7 \pm 1.5	37 \pm 13	
Mg		165 \pm 33	3.2 \pm 1.7	12,200 \pm 610	2,950 \pm 58	
Mn		79 \pm 1	6.9 \pm 0.1	347 \pm 160	31 \pm 0.6	
Mo		0.47 \pm 0.2	<0.01	7.7 \pm 0.5	0.73 \pm 0.3	
Na		611 \pm 180	65 \pm 14	1370 \pm 610	660 \pm 93	
Ni		4.8 \pm 0.06	0.6 \pm 0.2	44 \pm 1	11 \pm 0.6	1.4
P		234 \pm 5.3	18.7 \pm 1.6	5460 \pm 630	65 \pm 20	
Pb		1.2 \pm 0.8	<0.01	30 \pm 2	0.74 \pm 0.4	2.8
V		3 \pm 0.2	0.2 \pm 0.01	155 \pm 5	49 \pm 2	
Zn		17	0.8 \pm 0.1	75 \pm 31	9.4 \pm 2	

WEP-water extractable phosphorus; Al-WTR-alum-based water treatment residual; FGD-flue gas desulphurisation product.

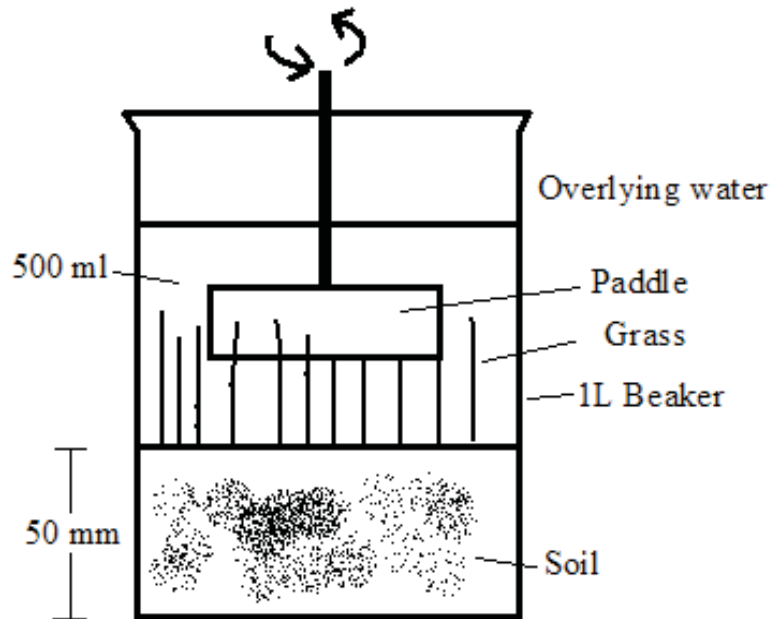

Figure 3.3 Schematic diagram of soil sample in agitator

Eight amendments were examined in an agitator test to control diffuse incidental P losses in runoff from slurry applied to permanent grassland. The amendments were divided into commercially available products (chemical amendments) including: industrial grade liquid alum ($\text{Al}_2(\text{SO}_4)_3 \cdot n\text{H}_2\text{O}$) containing 8% aluminium oxide (Al_2O_3); laboratory grade aluminum chloride ($\text{AlCl}_3 \cdot 6\text{H}_2\text{O}$); FeCl_2 and burnt lime ($\text{Ca}(\text{OH})_2$); and P sorbing materials (PSM): aluminium-based water treatment residuals, sieved to less than 2 mm (Al-WTR-1); Al-WTR homogenised sludge (Al-WTR-2); flyash; and FGD. Chemical amendments were applied based on Al:TP stoichiometric rate, and PSM were applied based on a kg kg^{-1} weight basis (slurry DM). The pH of the amended slurry was measured prior to application at $t=0$ h. Samples were taken to determine DM and WEP of the amended slurry (Kleinman et al., 2007). Slurry and amended slurry were applied to the surface of the grassed soil at a rate equivalent to 40 kg TP ha^{-1} ($50 \text{ m}^3 \text{ ha}^{-1}$ slurry). For each treatment, slurry samples ($n=3$) - with the same volume as applied to the grassed sample in the agitator test - were spread at the bottom of another beaker to allow pH and WEP to be measured at 24 h without disturbing the sample used in the agitator test.

Table 3.2 Table showing amendments in order of effectiveness score, breakdown of costs^a, cost/m³ slurry^b, cost for 100 cow farm, percentage reduction in DRP in overlying water and WEP of slurry at 24 h

Chemical ^c	Effectiveness score	Addition rate	Cost ^d € tonne ⁻¹	Rate kg m ⁻³	Cost amendment	Spreading € m ⁻³	Agitation € m ⁻³	Cost water ^e € m ⁻³	Total € m ⁻³	100 cow farm € farm ⁻¹	DRP % P	WEP (=24h) mg kg ⁻¹	WEP %
Control					0.00	1.58	0.33	0.00	1.91	1010		2.64±0.15	
FeCl ₂	1	2:1 Fe: P	250	12	2.92	1.57	0.34	0.00	4.82	2550	88	1.7±0.27	36
(FeCl ₃)		5:1 Fe: P		29	7.29	1.60	0.34	0.00	9.23	4870	90	0.2±0.06	72
		10:1 Fe: P		58	14.59	1.64	0.35	0.00	16.58	8750	99	0.5±0.02	81
AlCl ₃	2	0.98:1 Al: P	280	17	4.76	1.58	0.34	0.00	6.67	3520	87	2.06±0.06	21
(PAC)		1.22:1 Al: P		19	5.23	1.58	0.34	0.00	7.15	3770	92	1.43±0.02	46
		2.44:1 Al: P		37	10.45	1.61	0.35	0.00	12.41	6550	99	0.16±0.02	94
Alum	3	0.98:1 Al: P	150	19	2.82	1.60	0.34	0.00	4.76	2520	83	0.51±0.01	81
		1.22:1 Al: P		24	3.53	1.59	0.34	0.00	5.46	2880	94	0.27±0.07	90
		2.44:1 Al: P		47	7.07	1.62	0.35	0.00	9.04	4770	99	0.03±0.0	99
FGD	4	1.33 kg kg ⁻¹	14	150	2.03	3.23	0.69	2.14	8.09	4270	72	0.09±0.0	97
		2.65 kg kg ⁻¹		300	4.05	4.90	1.05	4.28	14.28	7540	89	0.05±0.0	98
		3.5 kg kg ⁻¹		400	5.40	5.84	1.26	5.45	17.95	9480	91	0.04±0.0	99
Flyash	5	2.1 kg kg ⁻¹	14	150	2.03	2.50	0.54	1.07	6.13	3240	43	0.92±0.14	65
		4.2 kg kg ⁻¹		300	4.05	3.62	0.78	2.37	10.82	5710	72	0.24±0.08	91
		5.6 kg kg ⁻¹		400	5.40	4.25	0.92	3.09	13.66	7210	81	0.22±0.04	92
Ca(OH) ₂	6	1:1 Ca: P	312	2	0.48	1.55	0.33	0.00	2.37	1250	0	2.43±0.06	9
		5:1 Ca: P		8	2.40	1.56	0.34	0.00	4.30	2270	74	1.52±0.02	42
		10:1 Ca: P		15	4.81	1.57	0.34	0.00	6.72	3550	81	0.4±0.0	85
Al-WTR-1 (<2 mm)	7	0.28 kg kg ⁻¹		20	-	-	-	-	-	-	31	2.49±0.06	6
		0.69 kg kg ⁻¹		50	-	-	-	-	-	-	77	1.73±0.02	34
		1.4 kg kg ⁻¹		100	-	-	-	-	-	-	74	0.93±0.02	65
Al-WTR-2 (sludge)	8	0.28 kg kg ⁻¹	5	63	0.31	1.65	0.35	0.00	2.31	1220	0	1.13±0.05	57
		0.69 kg kg ⁻¹		156	0.78	1.88	0.40	0.13	3.20	1690	71	0.28±0.01	89
		1.4 kg kg ⁻¹		313	1.56	2.52	0.54	0.72	5.34	2820	67	0.07±0.0	97

DRP-dissolved reactive P; WEP-water extractable P; Al-WTR-alum-based water treatment residual; FGD-flue gas desulphurisation product; ^aCalculations based on a dairy farm with 100 cows, or equivalent stocking rate, with a 18-wk winter; ^bSlurry properties: TP = 811 mg L⁻¹ and 7.2% DM; ^cWhere analytical grade products were used, cost was estimated using the most similar commercial product on the market (in brackets); ^dCost includes delivery of material and addition of material to slurry in storage tank; ^eAddition of some amendments resulted in DM >10%-water addition needed for spreading.

3.3.5. Water sampling and analysis

Water samples (4 ml) were taken from mid-depth of the water overlying the soil at 0.25, 0.5, 1, 2, 4, 8, 12 and 24 h after the start of each test (i.e after the 500 ml was added). All samples were filtered immediately after sample collection using 0.45 µm filters and placed in a freezer (APHA, 1995) prior to being analysed colorimetrically for DRP using a nutrient analyser (Konelab 20, Thermo Clinical Labsystems, Finland). The DRP concentrations were used to calculate the mass of DRP in the water overlying the soil samples in the beaker, taking into account the water volume reduction as the test progressed. All water samples were tested in accordance with standard methods (APHA, 1995). Figure 3.4 shows the P classification system used in this study (adapted from APHA).

3.3.6. Statistical Analysis

Proc Mixed (SAS, 2004) was used to model the factorial structures (amendment*application rate; and amendment*application rate*time) in the experiment in order to allow for heterogeneous variance across treatments. A group variable was fitted to allow comparisons between the control treatments and the factorial combinations. A multiple comparisons procedure (Tukey) was used to compare means.

3.3.7. Cost analysis

The cost of chemical amendment was calculated based on the estimated cost of chemical, chemical delivered to farm, addition of chemical to slurry, increases in slurry agitation, and slurry spreading costs as a result of increased volume of slurry due to the addition of the amendments. Slurry spreading costs were estimated based on data from Lalor (2008) and slurry agitating costs were estimated based on data from Anon (2008). The cost of water required to maintain DM at less than 10% was included, as DM must be less than 10% for ease of handling (Stan Lalor *pers com*, 2010). The feasibility of amendments

was determined based on effectiveness, rate, potential barriers to use and cost of implementation.

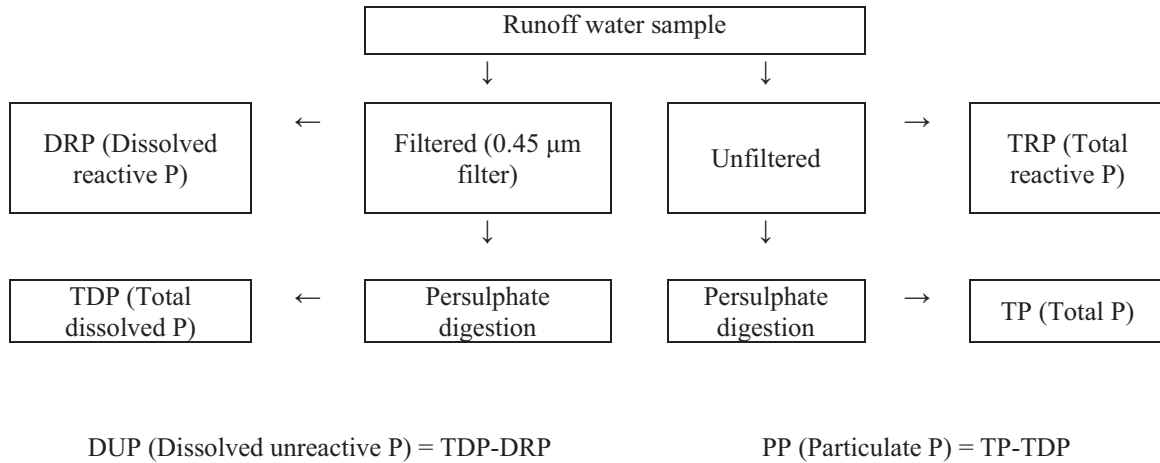

Figure 3.4 Phosphorus classification system used in this study (APHA, 1995)

3.4. Results

3.4.1. Results of agitator test

The amendments that were most effective at reducing DRP in overlying water were: FeCl_2 (99%), AlCl_3 (99%), alum (99%), FGD (91%), flyash (81%), lime (81%), Al-WTR-1 (71%) and Al-WTR-2 (77%). Figure 3.5 shows the mass of DRP in overlying for each treatment at each rate is shown in Figure 3.6. The amendments are ranked in decreasing order of effectiveness in Table 3.3. The irregularity between the 0.69 and 1.4 kg kg^{-1} amendment rates for Al-WTR-1 and Al-WTR-2 treatments were consistent across sieved and sludge treatments. However, this was not statistically significant. The overall statistical analysis showed that there was a significant interaction between treatment and application rate, but that the interaction effects were small compared to the main effects. Optimum application rates were determined based on achieving a similar level of P reduction for each of the amendments, while applying the minimum amount of metals to land, thus reducing risk due to land spreading of metals. Based on this criterion, optimum amendment rates were: FeCl_2 (2:1 (Fe:P)), AlCl_3 and alum (0.98:1 (Al:P)), FGD (1.33 kg kg^{-1}), flyash (4.2 kg kg^{-1}), lime (5:1 (Ca:P)), Al-WTR-1 and Al-WTR-2 (0.69 kg kg^{-1}).

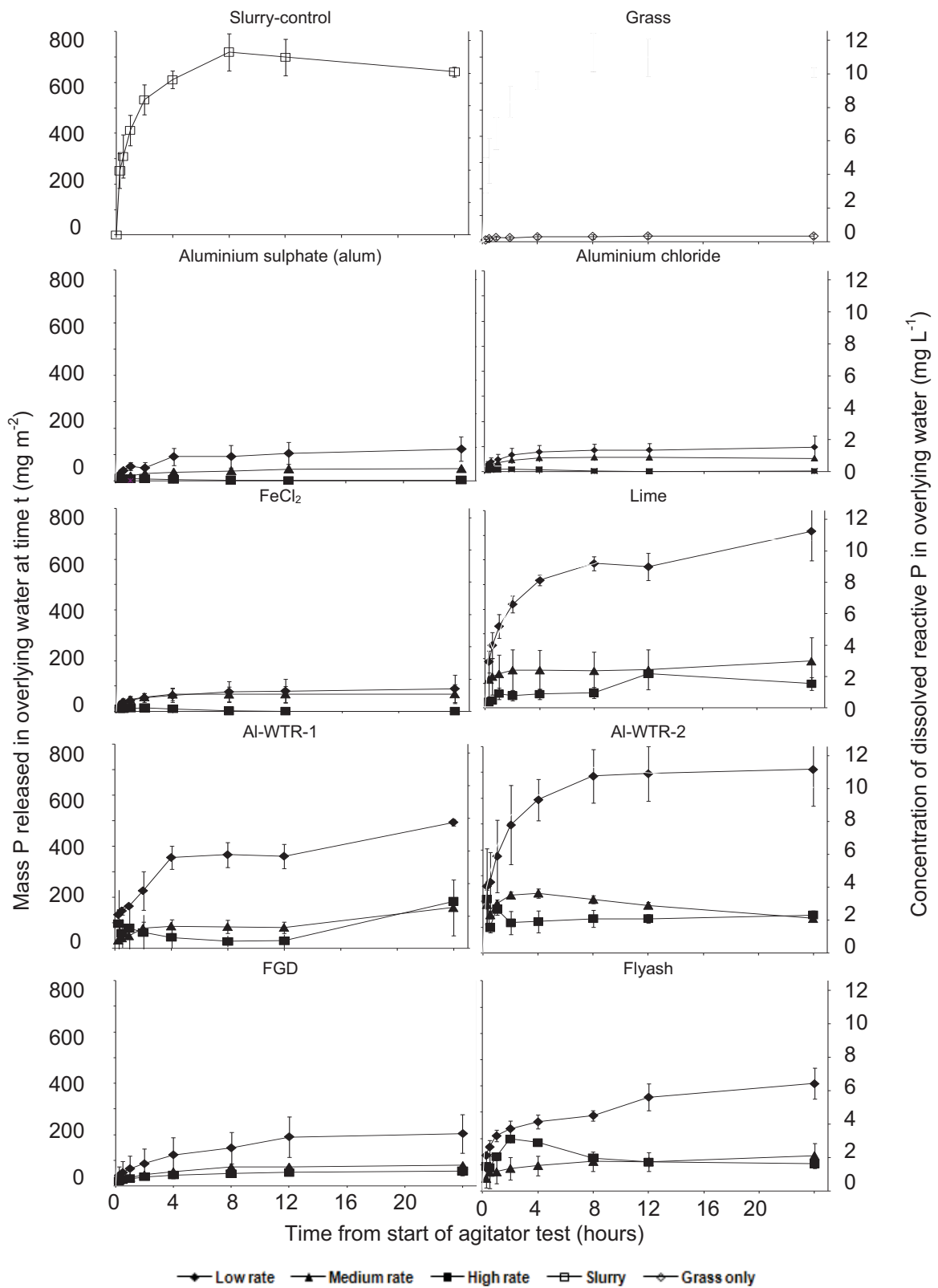

Figure 3.5 Mass of DRP and DRP concentration in overlying water

Linear regression showed a strong relationship between percentage reduction in slurry WEP and DRP in water overlying the soil for alum ($R^2=0.95$), $AlCl_3$ ($R^2=0.99$), Al-WTR-2 ($R^2=0.94$), flyash ($R^2=0.96$), FGD ($R^2=0.83$); and a smaller relationship for $FeCl_2$ ($R^2=0.60$), lime ($R^2=0.75$) and Al-WTR-1 ($R^2=0.67$). Only three rates were examined and there were insufficient points to quantify any relationship.

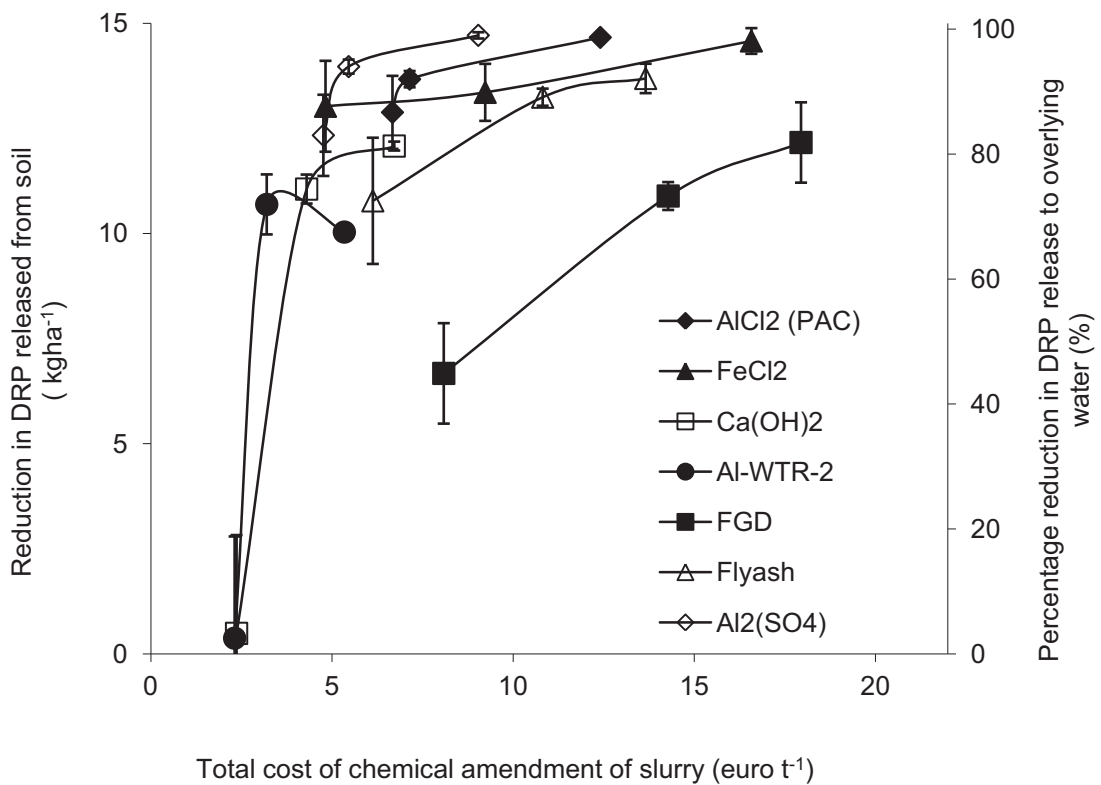

Figure 3.6 Total cost of chemical amendment of dairy cattle slurry plotted against the reduction in dissolved reactive phosphorus (DRP) lost to overlying water and the percentage reduction in DRP release to overlying water

3.4.2. Cost and feasibility analysis

The estimated cost of addition of amendments and increases in spreading and agitation costs due to amendments are presented in Table 3.2. The effects of amendments on slurry viscosity or handling were not considered in the cost analysis. It was assumed that

amendments would be added upon delivery, so storage cost on site was excluded from the analysis. For analytical grade products, the cost was estimated using the most similar commercial product available on the market. Starting with the cheapest, the amendments were ranked as follows: Al-WTR-2 (€3.20 m⁻³); Ca(OH)₂ (€4.30 m⁻³); alum (€4.76 m⁻³); FeCl₃ (€4.82 m⁻³); poly aluminium chloride (€6.67 m⁻³); FGD (€8.10 m⁻³) and flyash (€10.80 m⁻³).

Table 3.3 Feasibility of amendments

Chemical	Feasibility score	Addition rate	Total cost € m ⁻³	Reduction in DRP % P	Notes
Alum	1	0.98:1 Al: P	4.76	83	Risk of effervescence Risk of release of H ₂ S due to anaerobic conditions and reduced pH Cheap and used widely in water treatment
AlCl ₃ (PAC)	2	0.98:1 Al: P	6.67	87	No risk of effervescence (Smith et al, 2004) AlCl ₃ increased handling difficulty Expensive
FeCl ₂ (FeCl ₃)	3	2:1 Fe: P	4.82	88	Potential for Fe bonds to break down in anaerobic conditions Potential increased release of N ₂ O
Ca(OH) ₂	4	5:1 Ca: P	4.30	74	Risk of increased NH ₃ loss Strong odour Hazardous substance
Al-WTR-2 (sludge)	5	0.69 kg/kg	3.20	71	Waste product Risk of release of H ₂ S Composition varies with location and time Risk of P deficiency if over applied High application rates required Limited supply
FGD	6	1.33 kg/kg	8.10	72	High pH and therefore risk of increased NH ₃ loss Strong odour Large application rates required Settles quickly Potentially toxic
Flyash	7	4.2 kg/kg	10.80	72	Contains heavy metals Huge volume of water required Settles quickly Potentially toxic
Al-WTR-1 (<2 mm)	8	0.69 kg/kg	-	77	Excluded from cost analysis

The effect of amendments on slurry pH is a potential barrier to their implementation, as it affects P sorbing ability (Penn et al., 2011) and NH₃ emissions from slurry (Lefcourt and

Meisinger, 2001). Slurry pH results are shown in Figure 3.7. The acidifying additives (alum, AlCl_3 , FeCl_2) lowered the pH of the slurry. Lime and flyash addition increased the pH to 10.3 ($p < 0.0001$) and 9.3 ($p < 0.0001$), respectively. The use of these high pH amendments is likely to result in an increase in NH_3 emissions to the atmosphere from slurry. Risk of increased metal concentrations in overland flow is a significant barrier to the use of these amendments. No analysis of metals in the overlying water was undertaken in this experiment; therefore, feasibility considerations for metal application rates were based on the principle of applying the minimum metals necessary to reduce DRP in the overlying water. In addition, flyash was deemed unsuitable due to high concentrations of heavy metals contained within it.

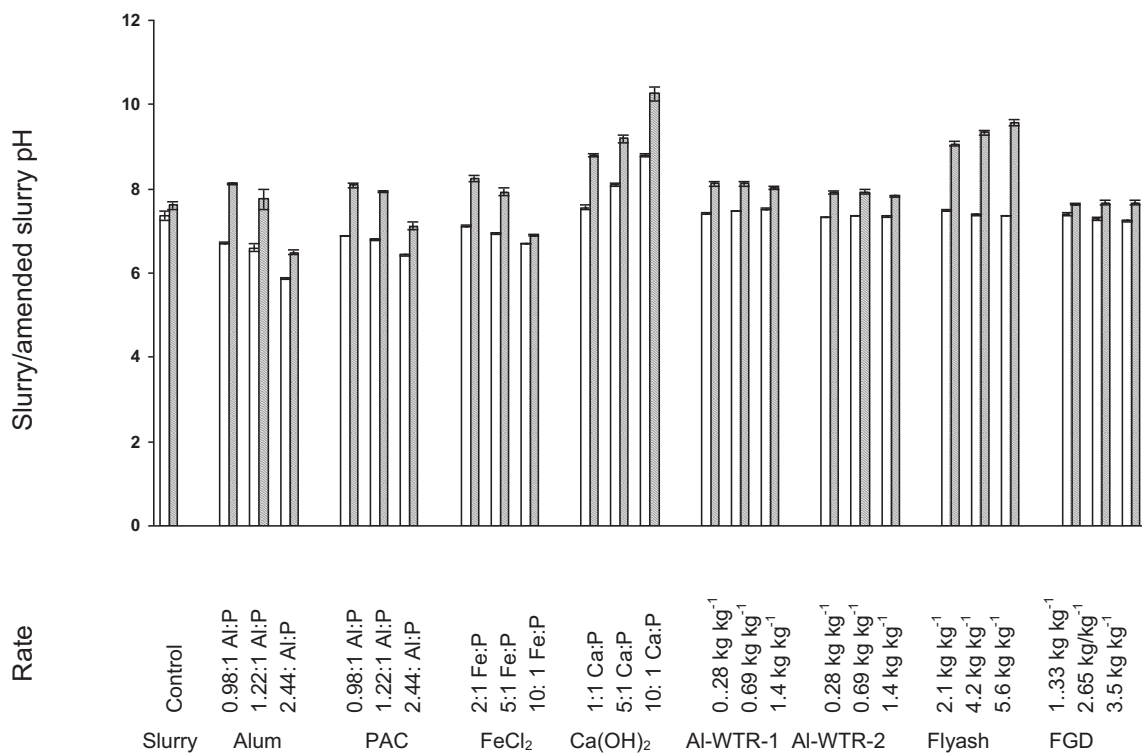

Figure 3.7 Histogram of slurry pH at time of amendment/application (clear box) and pH of slurry after 24 h (hatched box)

3.5. Discussion

Chemical amendment is an attractive means of mitigating against both incidental P losses from slurry and elevated P release from soil resulting from the increase in soil P due to slurry and chemical fertiliser application. It could be used in strategic areas for protection of a waterbody while allowing farmers to utilise other nutrients in slurry on farms with high STP. Ferric chloride, AlCl_3 and alum were the most effective amendments at optimum rates. Aluminium water treatment residuals, flyash and FGD are not feasible due to the large application rates needed and the risk of over-application of metals. Although chemical amendments are expensive, they are widely available and more efficient than PSM, and lower metal application rates are required to achieve adequate P reductions at optimum application rates.

The results for FeCl_2 , AlCl_3 , alum, and lime were in agreement with other studies. Lefcourt and Meisinger (2001) reported a 97% reduction in DRP of dairy cattle slurry when 2.5% by weight of alum was added in a laboratory batch experiment. The Al-WTR used in the present study was less effective than those observed in other studies. Penn et al. (2011) reported an 80% reduction in WEP of dairy slurry when slurry was amended at a rate equivalent to 0.2 kg kg^{-1} (compared to 71% observed in this study at 0.69 kg kg^{-1}). The results for the coal combustion by-products differed to previous studies. Dou et al. (2003) found that adding flyash to dairy manure at 0.4 kg kg^{-1} (manure DM) lowered soluble P by between 50 and 60% compared to 43% at 2.1 kg kg^{-1} in the present study. Penn et al. (2011) found that FGD was ineffective in treating dairy slurry when applied at 0.2 kg kg^{-1} , which was in contrast to the results of the present study (72% at 1.33 kg kg^{-1}). This difference could be due to the difference in composition of flyash. The mass of P released and DRP of the overlying water at any time for the duration of the experiment are shown in Figure 3.5. Throughout this study, an initial high rate of DRP release was followed by a period of slower release and, after 12 h, an approximate equilibrium DRP concentration was reached with the exception of the highest application rate of Al-WTR and all FGD treatments.

The stability, and thus the effectiveness, of different amendments over longer time spans (months, years) depends on farm management systems, drainage, and soils to which they are applied. For example, Al-P bonds are most stable in acidic soils, while Ca-P bonds are more stable in calcareous conditions (Wild, 1988). The effect of treatment on slurry pH at the time of application affects P sorption capacity of PSM containing Ca compounds, and NH₃ emissions from slurry. Changes in pH may reduce the pathogen load in slurry and subsequently pathogen transport to soil and runoff. Application of Al-WTR and FGD did not significantly change slurry pH. The soil used had optimum STP and only required P inputs sufficient to maintain P levels for future agronomic needs. Slurry amendment type (treatment), rate of amendment addition (rate), and their interaction had an effect on DRP in runoff ($p < 0.0001$; $R^2 = 0.96$). This strong relationship between slurry WEP and overlying water DRP would suggest that for this particular soil with this STP, soil type and STP had a minimum impact on results; in addition, any effect of STP would be constant across all treatments. Sharpley and Tunney (2000) reported that STP had little impact on the release of P to runoff for up to 14 d after dairy cattle slurry application.

There have been many reports of human and animal deaths from the release of the toxic hydrogen sulphide gas when slurry is being agitated on farms. The addition of chemicals such as alum that can lead to acidification of slurry and are likely to increase the release of toxic hydrogen sulphide gas and great care should be taken when adding acidifying chemicals to slurry on the farm.

Public and stakeholder opinion is the main obstacle for the use of chemical amendments. This study examined the feasibility of the amendments based on effectiveness, optimum rates and cost of treatment. Future work must address public concerns and examine the impact of amendments on gaseous emissions and metal build-up in the soil. If amendments to slurry are to be recommended (and adopted) as a method to prevent P losses in runoff, the impact of such applications on slurry-borne pathogens, as well as pathogen translocation to the soil and release in surface runoff, needs to be addressed. The long-term effects on microbial communities in soil must also be examined.

There is no provision for a licence to landspread any of these amendments in Ireland (lime is land applied in acidic soils to optimise soil pH for production) and if chemical amendment were to be used to mitigate P losses, a licensing system would have to be introduced by the Department of Agriculture in Ireland and relevant bodies in other countries.

3.6. Conclusions

The findings of this chemical amendment study are:

1. All amendments, when added to slurry, greatly reduced WEP of the slurry and DRP in water overlying soil.
2. Even at optimum amendment rates, the cost of slurry treatment increases slurry handling cost (between 250 and 560%) with the exception of Al-WTR, which is unfeasible due to high rates required, concerns over variation in composition, and limited supply.
3. These treatments currently seem to be expensive. However, they may be feasible if used strategically to mitigate P loss from dairy slurry in CSA within a farm, or as an alternative to applying slurry to high P soils.
4. Chemical amendments may have a role to play as part as P mitigation strategy

3.7. Summary

This chapter has determined the most effective amendments at reducing DRP release from land applied slurry to runoff. Chapter 4 details a runoff-box experiment designed to develop an understanding of the performance of chemical amendments under more realistic conditions. In addition to examining DRP, Chapter 4 examines how amendments affect SS, PP and TP losses. Chapter 4 also examines the effect of amendments on incidental loss of metals (Al, Ca and Fe) to runoff.

Chapter 4 Laboratory-scale rainfall simulation experiment

4.1. Overview

The agitator test identified amendments with great potential to reduce P solubility. A runoff box experiment was designed to develop our understanding of the performance of amendments under more realistic conditions.

4.2. Introduction

Chemical amendments of slurry using Al, Fe, or Ca based compounds reduce P solubility in manure (Dao, 1999; Dou et al., 2003; Kalbasi and Karthikeyan, 2004) and reduce P in runoff from plots receiving alum amended poultry litter (Moore and Edwards, 2005) with negligible effect on metal loss (McFarland et al., 2003). Chemical amendments reduce incidental P losses by a combination of the formation of stable metal-phosphorus precipitates (such as Al-P phosphates in the case of alum) and flocculation of the particles in the slurry to form larger particles, which are less prone to erosion (Tchobanoglous et al., 2003). Previous studies have found that there was no risk of increased metal release posed by chemical amendment of poultry litter (Moore et al., 1998), dirty water (McFarland et al., 2003), or horse manure (Edwards et al., 1999). The present study examines for the first time the effect of chemical amendment of dairy cattle slurry on both P and metal (namely Al, Fe and Ca) losses to runoff, whereas most previous studies only examined the effect of amendments on P solubility (Dao, 1999; Dao and Daniel, 2002; Dou et al., 2003).

4.3. Materials and Methods

4.3.1. Soil sample collection and analysis

Intact grassed-soil samples, 70 cm-long by 30 cm-wide by 10 cm deep, were collected from a dairy farm in Athenry, Co. Galway (53°21'N, 8°34' W). A second set of soil samples, taken to a depth of 10 cm below the ground surface from the same location, was air dried at 40 °C for 72 h, crushed to pass a 2 mm sieve, and analysed for Morgan's P (the national test used for the determination of plant available P in Ireland) using Morgan's extracting solution (Morgan, 1941). Soil pH (n=3) was determined using a pH probe and a 2:1 ratio of deionised water-to-soil. Particle size distribution was determined using B.S.1377-2:1990 (BSI, 1990a). Organic content of the soil was determined using the loss of ignition test (B.S.1377-3; BSI, 1990b). The soil was a poorly-drained sandy loam (58% sand, 27% silt, 15% clay) with a Morgan's P of 22±3.9 mg P L⁻¹, a pH of 7.45±0.15 and an OM content of 13±0.1%. The soil had a sandy loam texture, which points to moderate drainage on site. However, medium permeable subsoil limits drainage. Historic applications of organic P from an adjacent commercial-sized piggery have led to high STP in the soil used in this study.

4.3.2. Slurry collection and analysis

Cattle slurry from dairy replacement heifers was taken from a farm (53°18' N, 8°47' W) in County Galway, Republic of Ireland in Winter (February), 2010. The storage tanks were agitated and slurry samples were transported to the laboratory in 10-L drums. Slurry samples were stored at 4°C. Slurry and amended slurry pH was determined using a pH probe (WTW, Germany) and the WEP of slurry was measured at the time of land application after Kleinman et al. (2007). Dry matter content was determined by drying at 105 °C for 16 h. The TP of the dairy cattle slurry was determined after Byrne (1979). Total potassium, TN and TP were carried out colorimetrically using an automatic flow-through unit (Varian Spectra 400 Atomic Absorption instrument). Ammoniacal nitrogen of slurry and amended slurry was extracted from fresh slurry by shaking 10 g of slurry in

200 ml 0.1 M HCl on a peripheral shaker for 1 h and filtering through No 2 Whatman filter paper.

4.3.3. Slurry amendment and runoff set-up

The results of a laboratory micro-scale study (Chapter 3) (Data shown in Appendix C) were used to select chemical amendments to be examined in the present study. In addition to a grassed soil-only treatment, five treatments were examined: (1) slurry-only (the study control) (2) industrial grade liquid alum ($\text{Al}_2(\text{SO}_4)_3 \cdot n\text{H}_2\text{O}$), comprising 8% aluminium oxide (Al_2O_3) applied at a rate of 1.11:1 (Al:TP) (3) industrial grade liquid poly-aluminium chloride hydroxide (PAC) ($\text{Al}_n(\text{OH})_m\text{Cl}_{3n-m}$) comprising 10% Al_2O_3 at a rate of 0.93:1 (Al:TP) (4) analytical grade FeCl_2 at a rate of 2:1 (Fe:TP), and (5) burnt lime ($\text{Ca}(\text{OH})_2$) at a rate of 10:1 (Ca:TP). The rates used were based on the results of Chapter 3.

A batch experiment was also conducted using a range of amendment concentrations to construct a multi-point Langmuir isotherm (McBride, 2000):

$$\frac{P}{x/m} = \frac{1}{ab} + \frac{P}{b} \quad (4.1)$$

where P is the concentration of P in solution at equilibrium (mg L^{-1}), x/m is the mass of P adsorbed per unit mass of amendments (g kg^{-1}) at P , a is a constant related to the binding strength of molecules onto the amendments, and b is the theoretical amount of P adsorbed to form a complete monolayer on the surface. This provided an estimate of the maximum adsorption capacity of the amendments (g kg^{-1}). These results are shown in Figure 4.1. The amendments were added at a range of rates to 500 g slurry samples and mixed rapidly for 10 min at 100 rpm using a jar test flocculator. The samples were incubated at 11°C for 24 h. Following incubation, 50 g of slurry/amended slurry was mixed with 250 ml of distilled water. The slurry-water solution was then placed on a reciprocating shaker for 1 h. Samples were centrifuged at 14,000 rpm for 5 min to separate the solids from the

solution before being passed through a 0.45 μm filter and the P extract was determined using a Konelab nutrient analyser (Konelab 20, Thermo Clinical Labsystems, Finland).

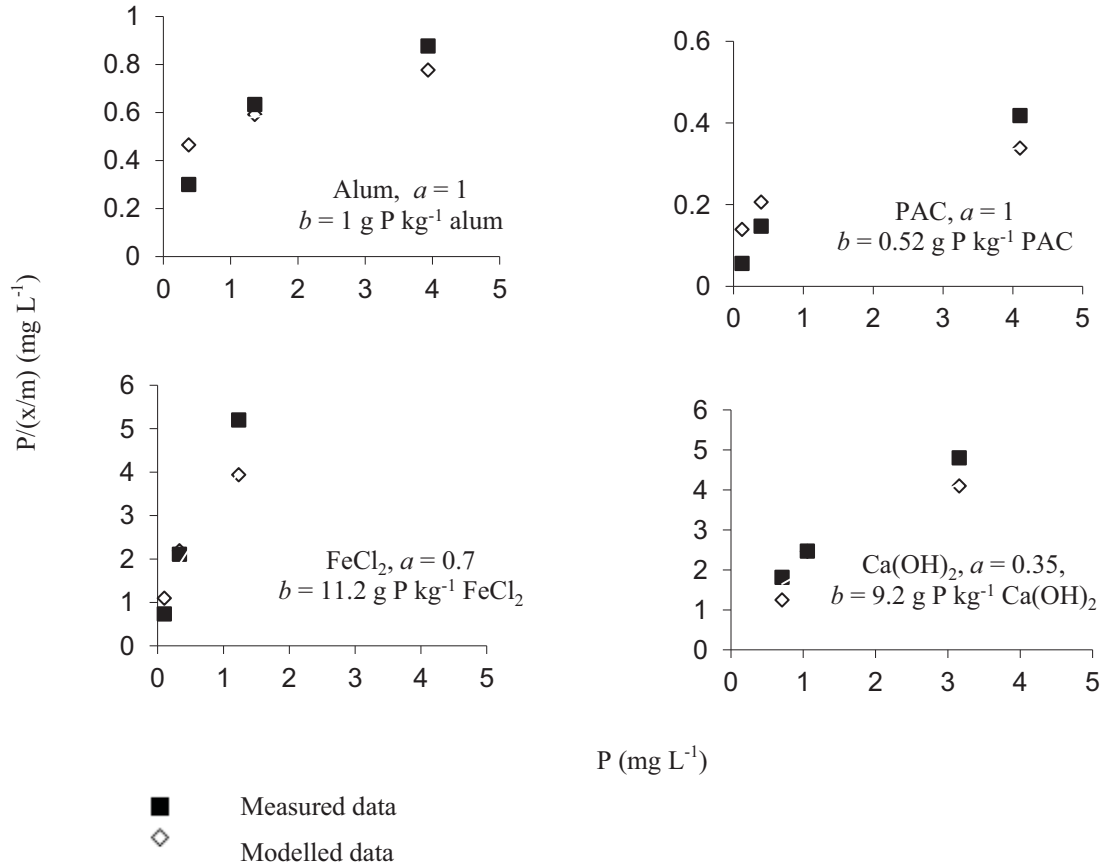

Figure 4.1 Langmuir isotherm fitted to phosphorus in amended slurry data

The equilibrium P concentration (EPC_0) (i.e. the point where no net desorption or sorption occurs) was derived using the following formula (Olsen and Watanabe, 1957):

$$S' = k_d P - S_0 \quad (4.2)$$

where S' is the mass of P adsorbed from slurry (mg kg^{-1}), P is the final P concentration of the solution, k_d is the slope of the relationship between S' and P , and S_0 is the amount of P originally sorbed to the amendment (mg L^{-1}). The EPC_0 was determined graphically (Figure 4.2).

A slurry sample (from the same storage tank as used in the surface runoff experiments) with a DM of 6%, TP of 550 mg L⁻¹ and WEP of 2.26 g kg⁻¹ was used for the isotherm study. An approximate metal: soluble P ratio for each amendment was calculated using the *b* term from the Langmuir isotherm and WEP of the slurry. The isotherm results indicated that lower application rates should be sufficient to bind P in slurry. However, as the experiment detailed in Chapter 3 was considered to best replicate runoff, it was decided to base the application rates on the results of Chapter 3 and not the batch test used to develop the Langmuir isotherm. As one of the main aims of the present study was to investigate the effect of amendments on metal release, it was considered to be reasonable and conservative to use results from Chapter 3.

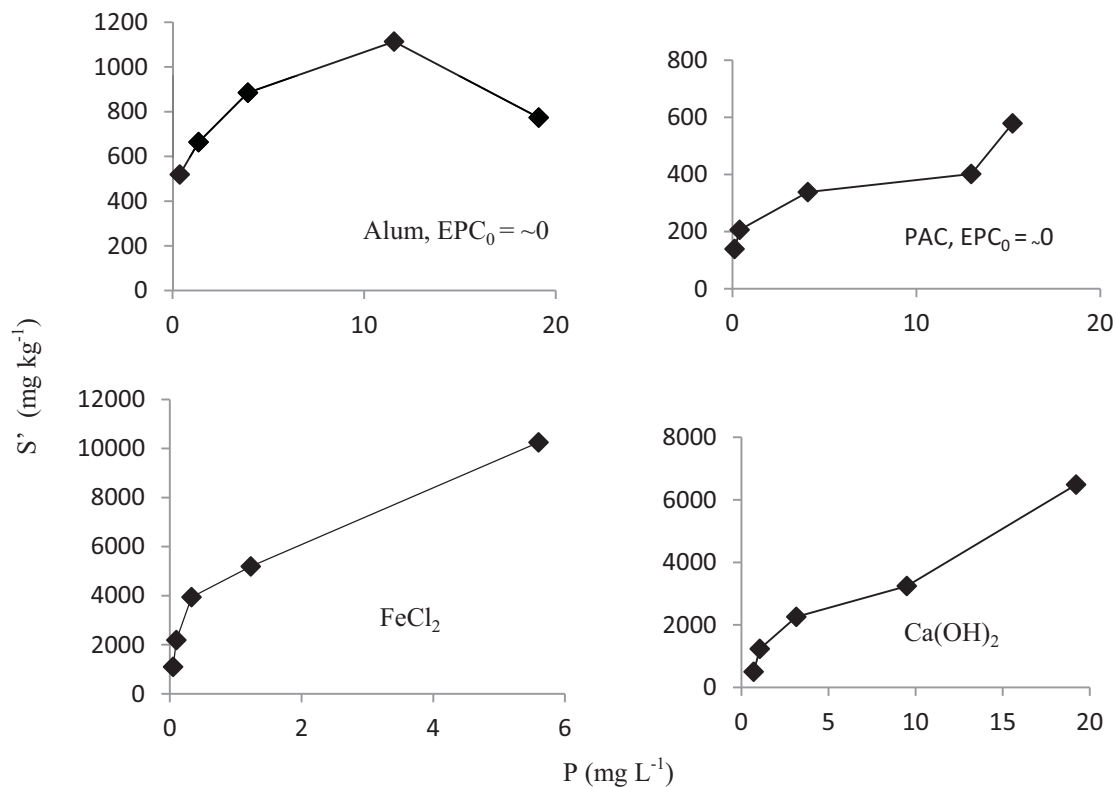

Figure 4.2 Phosphorus sorption isotherms for amended slurry data

A laboratory runoff box study was chosen over a field study as it was less expensive and allowed testing under standardized conditions. Such studies are a widely used tool in P transport research to compare treatments (Hart et al., 2004). This experiment used two

laboratory runoff boxes, 200-cm-long by 22.5-cm-wide by 5-cm-deep with side walls 2.5 cm higher than the soil surface, and 0.5-cm-diameter drainage holes located at 30-cm-centres in the base (after Regan et al., 2010). Cheese cloth was placed at the base of each runoff box before placing the sods to prevent soil loss. Intact grassed sods from the study site were transported to the laboratory and stored at 11°C in a cold room prior to testing. All experiments were carried out within 14 d of sample collection and tests were conducted in triplicate (n=3). Immediately prior to the start of each runoff box experiment, new sods were trimmed and placed in the runoff box; each slab was butted against its adjacent slab to form a continuous surface. Molten candle wax was used to seal any gaps between the soil and the sides of the runoff box, while the joint between adjacent soil samples did not require molten wax.

The packed sods were then saturated using a rotating disc, variable-intensity rainfall simulator (after Williams et al., 1998), comprising a single 1/4HH-SS14SQW nozzle (Spraying Systems Co., Wheaton, IL) attached to a 450-cm-high metal frame, and calibrated to achieve an intensity of $11.5 \pm 1 \text{ mm h}^{-1}$ and a droplet impact energy of $26 \text{ kJ cm}^{-1} \text{ ha}^{-1}$ at 85% uniformity. The sods were then left to drain for 24 h before the experiment commenced; the grassed sods were then assumed to be at an approximate 'field capacity' (Regan et al., 2010). Amendments were added to the slurry and mixed rapidly (10 min at 100 rpm) using a jar test flocculator immediately prior to land application. Slurry and amended slurry were applied directly to the surface of the intact grassed soil in runoff boxes at a rate equivalent to $33 \text{ m}^3 \text{ slurry ha}^{-1}$ (26 kg TP ha^{-1}), the rate most commonly used in Ireland (Coulter and Lalor, 2008). Figure 4.3 shows soil sods before and after slurry application.

During each rainfall simulation event, rain was applied until runoff water flowed continuously and then for 1 h while runoff water samples were collected. The drainage holes on the base of the runoff boxes were sealed to better replicate field conditions and to ensure that overland flow occurred. Figure 4.4 shows the laboratory setup.

a



b

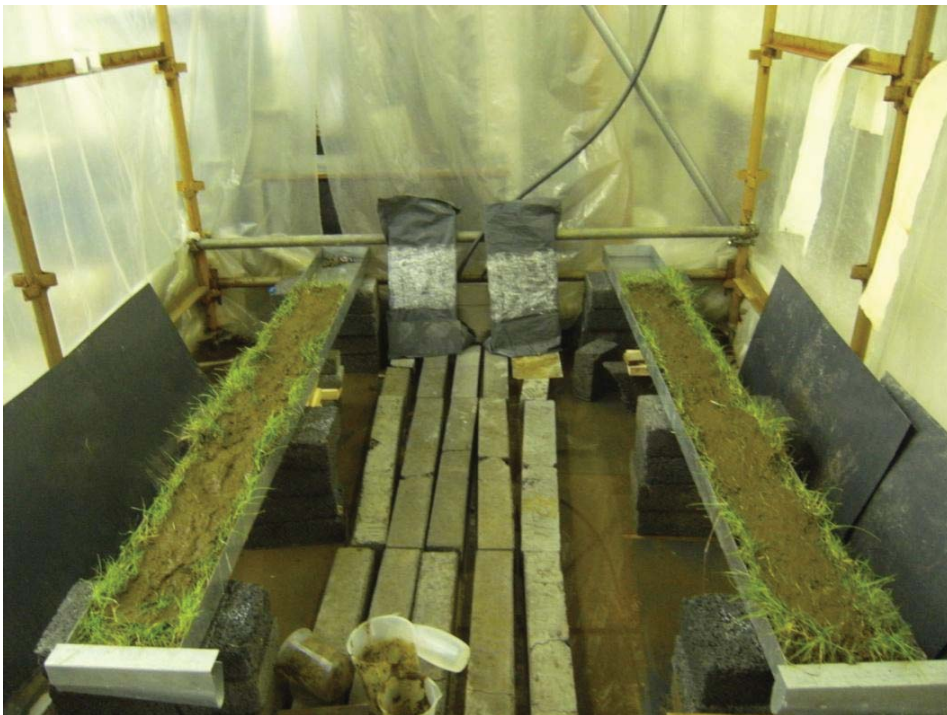

Figure 4.3 Runoff box immediately (a) before and (b) after slurry application



Runoff box cleaned prior to each rainfall simulation



Muslin cloth cut to length to prevent soil loss and aid drainage



Runoff box ready for soil to be placed



Soil sample trimmed immediately prior to placement



Soil samples placed in flume starting at lower end



View of runoff box with one sod

Figure 4.4 Photographs showing soil sod preparation and placement methodology

The first rainfall simulation (RS1) commenced 48 h after slurry application, then after a 1 h interval the second rainfall simulation (RS2) commenced. The drainage holes at the bottom of the runoff box were opened for a 24 h interval and then closed when the third rainfall event (RS3) commenced. As the soil samples were taken from the mid-slope of a field with a slope of approximately 5%, it would have been unrealistic to allow the soil to remain water-logged for 24 h between RS2 and RS3. All of the surface runoff was collected at 5-min intervals once runoff began. The source for the water used in the rainfall simulations had a DRP concentration of less than 0.005 mg L^{-1} , a pH of 7.7 ± 0.2

and an electrical conductivity (EC) of 0.435 dS m⁻¹. Runoff water pH and EC were measured immediately prior to each event using a pH and EC meter.

4.3.4. Sample handling and analysis

Runoff samples were collected in 1 L containers (covered to prevent rain water entering container) at the bottom of the runoff box. Immediately after collection, a subsample of the runoff water was passed through a 0.45µm filter and a sub-sample was analysed colorimetrically for DRP using a nutrient analyser (Konelab 20, Thermo Clinical Labsystems, Finland). A second filtered sub-sample was analysed for TDP using potassium persulfate and sulfuric acid digestion (HACH LANGE, Germany). Unfiltered runoff water samples were also collected and TP was measured using the method used for TDP analysis. Particulate P was calculated by subtracting TDP from TP. The DRP was subtracted from the TDP to give the DUP.

Suspended sediment were determined for all samples by vacuum filtration of well-mixed, unfiltered runoff water through Whatman GF/C (pore size: 1.2 µm) filter paper. All water samples were tested in accordance with standard methods for the examination of water and wastewater (APHA, 1995). In order to address the concern of metal release from amendments, identified by Fenton et al. (2008), it was decided to measure Al, Ca and Fe as these were the active metals in the chemical amendments added to slurry. The metal content was determined using an ICP (inductively coupled plasma) VISTA-MPX (Varian, California). The limit of detection for Al and Fe was 0.01 mg L⁻¹ and 1 mg L⁻¹ for Ca.

4.3.5. Statistical analysis

The structure of the experiment was a one-way classification with the rainfall events being repeated measures on each experimental unit. Proc Mixed of SAS (2004) was used to analyse the concentrations of DRP, DUP, PP, TP, SS, Al, Ca and Fe with a covariance structure to account for correlations between the repeated measures. An unstructured

covariance model was used for most variables and the outcome was interpreted as a factorial of treatment x event. In all cases, the treatment by event interactions were examined. The data for Al and Fe were censored by a limit of detection and PROC NLMIXED of SAS was used to fit a censored Normal-based model while accounting for the correlations by inducing a compound symmetry structure with a random effect.

4.4. Results

4.4.1. Slurry and amended slurry analysis

The results of the slurry analysis are shown in Table 4.1. The slurry sample was typical of slurry found on farms in Ireland (SI 610 of 2010) with a high DM on the upper limit for land application (Stan Lalor *pers com*, 2011). The slurry TP and TK remained relatively constant. At the rates used in this study, all of the amendments examined reduced the WEP of dairy cattle slurry by approximately 99% compared to the slurry-control ($p < 0.001$). Alum addition reduced slurry pH from approximately 7.5 (control) to 5.4, PAC reduced pH to 6.4 and FeCl_2 to 6.7 ($p < 0.001$), while lime addition increased slurry pH to 12.2 ($p < 0.001$). Chemical amendment also changed the appearance of slurry (Figure 4.5)

Table 4.1 Stoichiometric ratio at which the amendments were applied and slurry dry matter (DM), pH and average concentrations of $\text{NH}_4\text{-N}$, water extractable phosphorus (WEP), total nitrogen (TN), total phosphorus (TP) and total potassium (TK) (n=3)

	Rate	DM %	pH	$\text{NH}_4\text{-N}$ mg L^{-1}	WEP $\text{g kg}^{-1}\text{DM}$	TN mg L^{-1}	TP mg L^{-1}	TK mg L^{-1}
Slurry		10.5 (0.04)	7.47 (0.1)	1760 (123)	2.22 (0.34)	4430 (271)	1140 (76)	4480 (218)
Alum	1.1:1 [Al:TP]	9.4 (0.16)	5.40 (0.1)	1770 (21)	0.002 (0.0004)	4570 (176)	1140 (69)	4360 (84)
PAC	0.93 [Al:TP]	9.6 (0.28)	6.37 (0.1)	1760 (143)	0.0013 (0.0003)	4750 (448)	1180 (165)	4680 (448)
Lime	10:1 [Ca:TP]	8.2 (0.29)	12.2 (0.1)	1320 (141)	0.0056 (0.0003)	3190 (263)	1140 (96)	4810 (227)
FeCl_2	2:1 [Fe:TP]	10.1 (0.22)	6.7 (0.1)	1700 (11)	0.0022 (0.0006)	4340 (372)	1120 (51)	4720 (386)

(standard deviation in brackets)

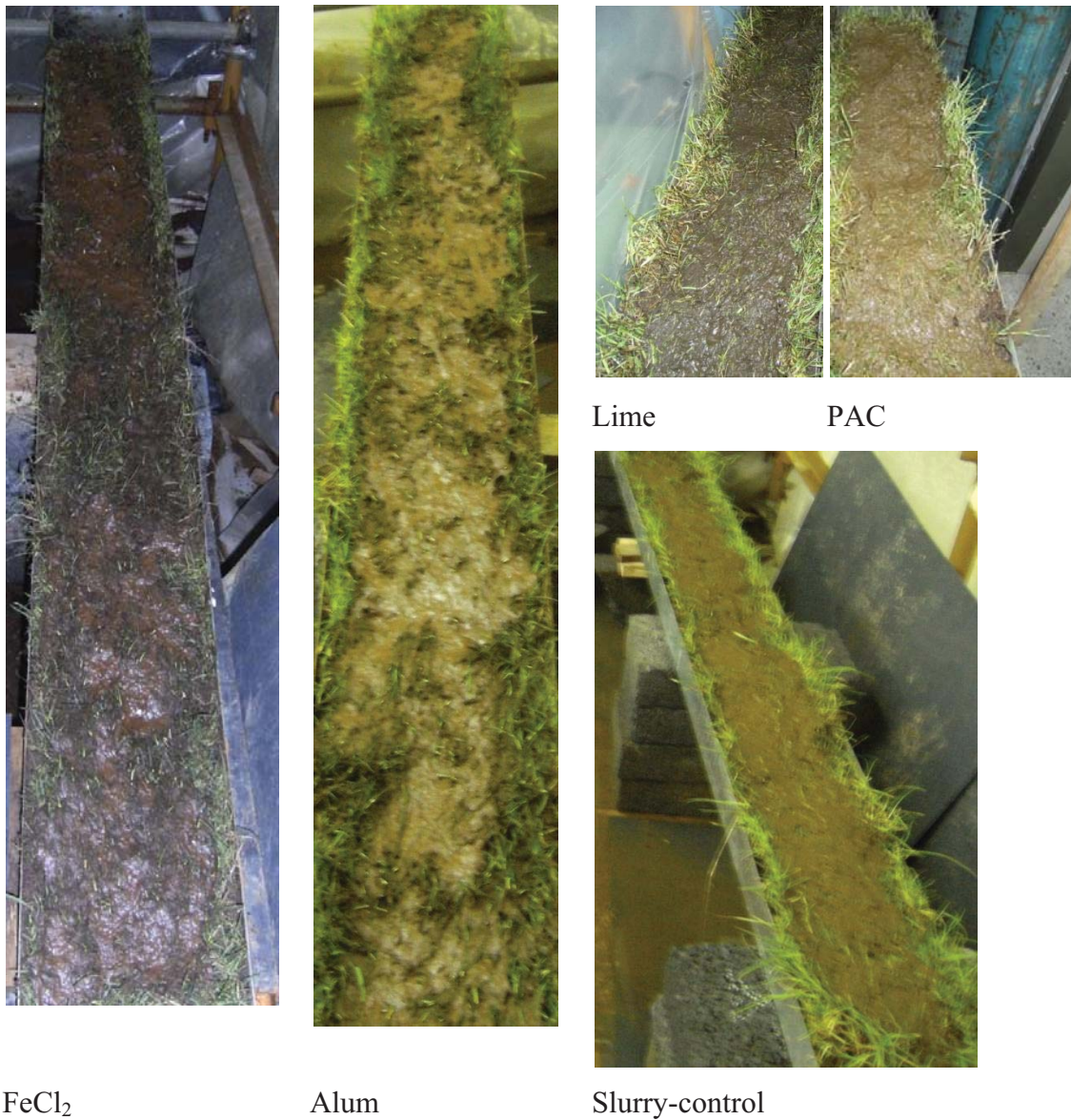

Figure 4.5 Photographs of slurry and amended slurry immediately after application to grassed soil in boxes

4.4.2. Water quality analysis

The average flow-weighted mean concentrations (FWMC) of DRP, DUP and PP in runoff for the three rainfall events are shown in Figure 4.6. Alum ($114 \mu\text{g DRP L}^{-1}$) and PAC ($89 \mu\text{g DRP L}^{-1}$) were more effective at reducing DRP concentration than lime ($200 \mu\text{g DRP L}^{-1}$) and FeCl₂ ($200 \mu\text{g DRP L}^{-1}$). At the rates used, all of the treatments

examined resulted in DRP concentrations in runoff greater than the MAC for surface waters. However, the buffering capacity of water means that the concentration of a surface waterbody will not be as high as the concentration of runoff, provided runoff from slurry flows over soil which has not received dairy cattle slurry (McDowell and Sharpley, 2002b).

The average concentrations of P in runoff water for the 3 rainfall simulation events were 171 $\mu\text{g DRP L}^{-1}$, 91 $\mu\text{g DUP L}^{-1}$ and 373 $\mu\text{g TP L}^{-1}$ for grassed soil-only treatment compared to 655 $\mu\text{g DRP L}^{-1}$, 1,290 $\mu\text{g DUP L}^{-1}$ and 8,390 $\mu\text{g TP L}^{-1}$ for the slurry-control. Incidental DRP and TP concentrations in runoff water following land application of dairy cattle slurry were 5 and 14 times greater than those from grassed-soil. In the present study, alum ($p<0.001$), PAC ($p<0.001$), lime ($p<0.05$) and FeCl_2 ($p<0.05$) reduced DRP losses significantly compared to the slurry-control with reductions similar to those observed in Chapter 3. The results of both studies are tabulated in Table 4.2. The average FWMC of TDP was significantly reduced compared to the slurry-control. The difference between grass-only, alum and PAC treatments was not significant and the difference between lime and FeCl_2 was also not significant. The average FWMC of DUP was also significantly reduced for all treatments compared to slurry-control.

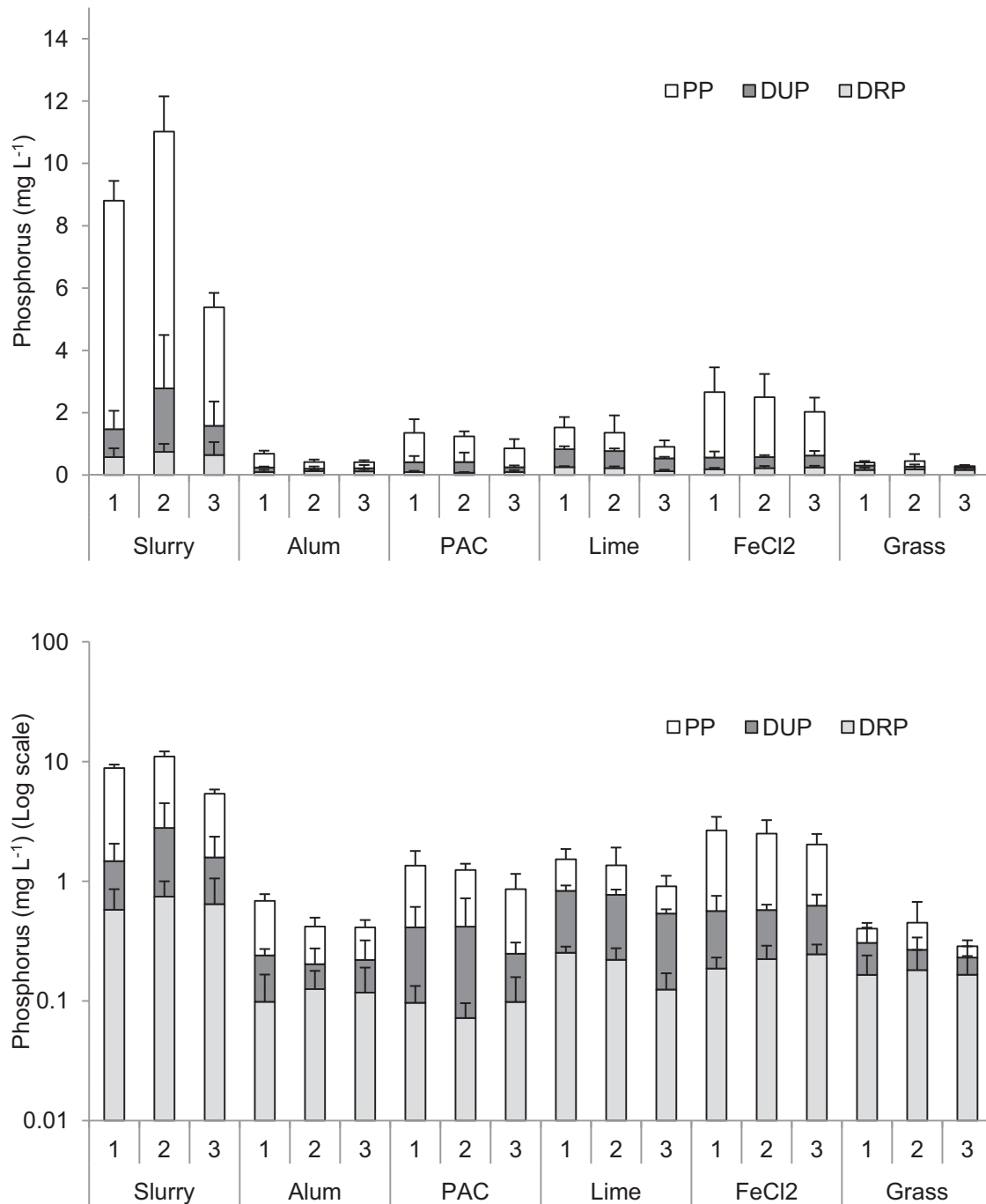

Figure 4.6 The average flow-weighted mean concentration of dissolved reactive phosphorus (DRP), dissolved unreactive phosphorus (DUP) and particulate phosphorus (PP), which comprise total phosphorus (TP) in runoff from three rainfall simulation events.

Table 4.2 Results from Chapter 3 and 4, showing cost of treatments and total phosphorus (TP) lost from runoff box

	Chapter 3 stoichiometric ratio	DRP reduction	Chapter 4 stoichiometric ratio	DRP reduction	Cost per m ³ slurry	TP lost as % TP applied	Cost per kg P reduction	P lost
	metal: TP	%	metal: TP	%	€ m ⁻³		€ kg P ⁻¹	kg P ha ⁻¹
Slurry	-	-	-	-	1.90	7.70	-	2.90
Alum	0.98:1	87	1.11:1	83	7.40	0.46	66.70	0.17
PAC	0.98:1	88	0.93:1	86	8.80	1.05	91.10	0.40
Lime	5:1	74	10:1	69	10.20	1.16	111.00	0.44
FeCl ₂	2:1	88	2:1	67	7.00	2.20	61.00	0.19

^aTaken from Chapter 3.

^b The cost m⁻³ and cost effectiveness have been updated from Chapter 3 to reflect the slight change in ratio of metal:TP in the present runoff box study.

^cLaboratory grade aluminium chloride (Al₂(SO₄)₃.nH₂O) was used in Chapter 3. Commercially available commercial grade liquid poly-aluminium chloride was used in the present study.

Note: All treatments were found to be significantly different to the control ($p < 0.001$) in the Chapter 3 study. However, these were not significantly different to each other. In this study, all treatments were significantly different to the slurry-control. Alum and AlCl₃ were significantly different to lime and FeCl₂, but not to each other. (€1.00 is approximately equal to \$1.37 or £1.59)

There was no significant difference between TP in runoff water from grass-only (373 µg L⁻¹) and alum treatments (506 µg L⁻¹). However, there was a significant difference between grass-only and PAC (1,150 µg L⁻¹) ($p < 0.001$), lime (1,270 µg L⁻¹) and FeCl₂ (2,400 µg L⁻¹) treatments for TP ($p < 0.001$), with a less significant difference between grass-only and PAC (790 µg L⁻¹) and Fe (1,730 µg L⁻¹) for PP ($p < 0.001$). Therefore, alum was the best amendment at reducing TP and PP loss to runoff. Table 4.2 shows the TP lost in the runoff expressed as a percentage of the slurry applied. The TP losses from the control were in agreement with Preedy et al. (2001), who reported that between 6 and 8% of TP applied was lost to runoff. The TP in runoff from the grass-only treatment comprised approximately 47% DRP compared to 69% reported by Haygarth et al. (1998). This difference may be a result of scale effects or differences in experiment design. While chemical amendment of dairy slurry significantly reduced DRP, DUP, PP and TP in runoff water, the proportions of each fraction in runoff from alum, PAC and FeCl₂ treatments were similar to the slurry-control (Figure 4.7).

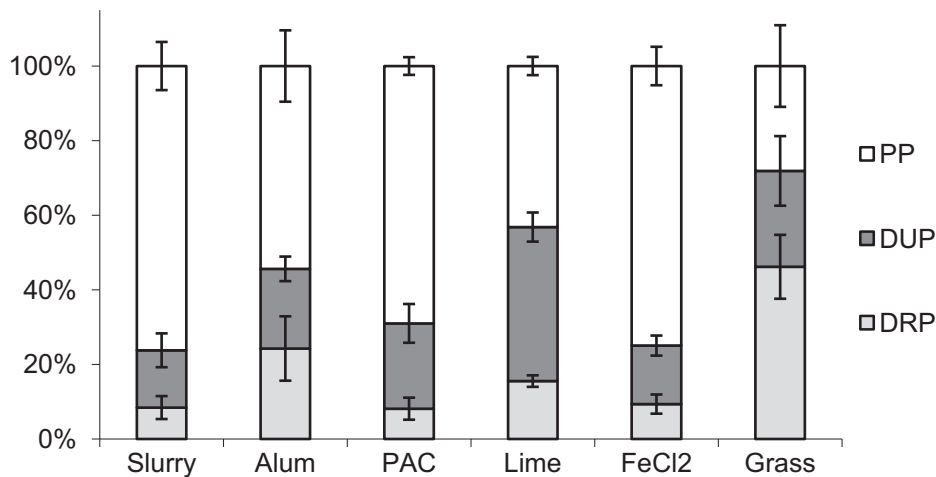

Figure 4.7 The average % of dissolved reactive phosphorus (DRP) dissolved unreactive phosphorus (DUP) and particulate phosphorus (PP), which comprise total phosphorus (TP) in runoff after three rainfall simulation events

Suspended sediment was 162 mg L^{-1} for the grass-only treatment compared to $3,030 \text{ mg L}^{-1}$ for the slurry-control (Figure 4.8). Alum resulted in the greatest reduction in SS (an average of 88% for the three rainfall events compared to the slurry-control) ($p < 0.001$). There was no statistical difference in average FWMC of SS between alum, PAC (83% reduction) and lime (82%). All of the treatments resulted in SS concentrations in the runoff which were significantly greater than the grass-only treatment ($p < 0.005$).

4.4.3. Metals in runoff water

The average FWMC of Al, Ca and Fe for the 3 rainfall simulation events are shown in Figures 4.9, 4.10 and 4.11. The average concentrations of metals tested in runoff water for the 3 rainfall simulation events were greater for the slurry-control than the grass-only treatment. Aluminium concentrations increased from 60 to $91 \text{ } \mu\text{g Al L}^{-1}$ (not statistically significant), Ca from 84 to 108 mg L^{-1} ($p < 0.01$), and Fe increased from 71 to $151 \text{ } \mu\text{g L}^{-1}$ ($p = 0.02$, RS2).

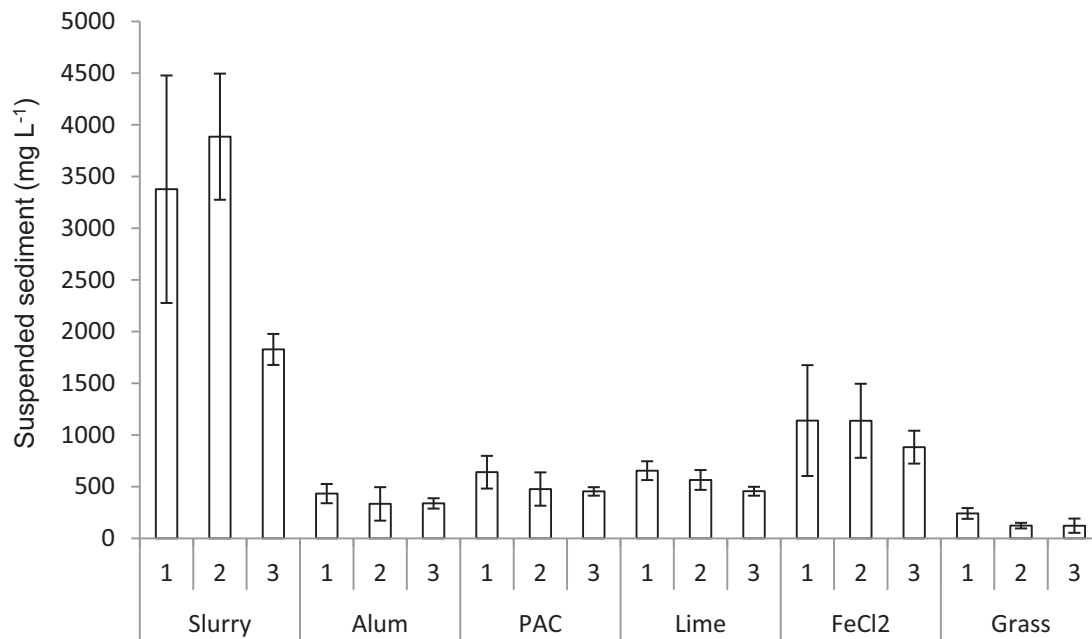

Figure 4.8 Average flow-weighted mean concentrations of suspended sediment in runoff

The FWMC of Al decreased for all treatments compared to the slurry-control (Figure 4.9). There was a significant treatment x event interaction ($p < 0.001$) and differences between events within treatments and between treatments within events were tested. After multiple comparison adjustments, there were no statistically significant differences between treatments. There were some significant decreases to the RS3 event compared to RS1 and RS2 for the lime and slurry-control treatments ($p = 0.03$ and $p = 0.006$). The FWMC of Ca in runoff from all chemically amended slurry treatments was significantly greater than from the slurry-control and the grass-only treatment ($p < 0.01$) (Fig. 4.10).

The treatment by event interaction was significant and while no treatments were statistically different across all events, there were some differences between the grass treatment and both alum ($p = 0.02$, RS1) and the slurry-control ($p = 0.02$, RS2), and also between the FeCl₂ and the slurry-control ($p = 0.02$, RS2).

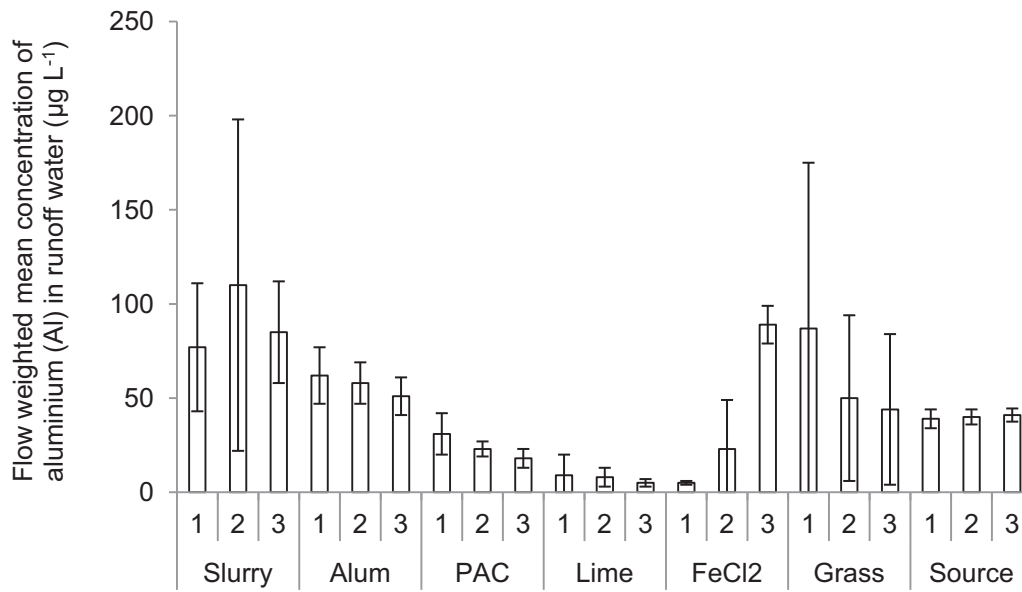

Figure 4.9 Average flow-weighted mean concentrations of Al in runoff and rain water

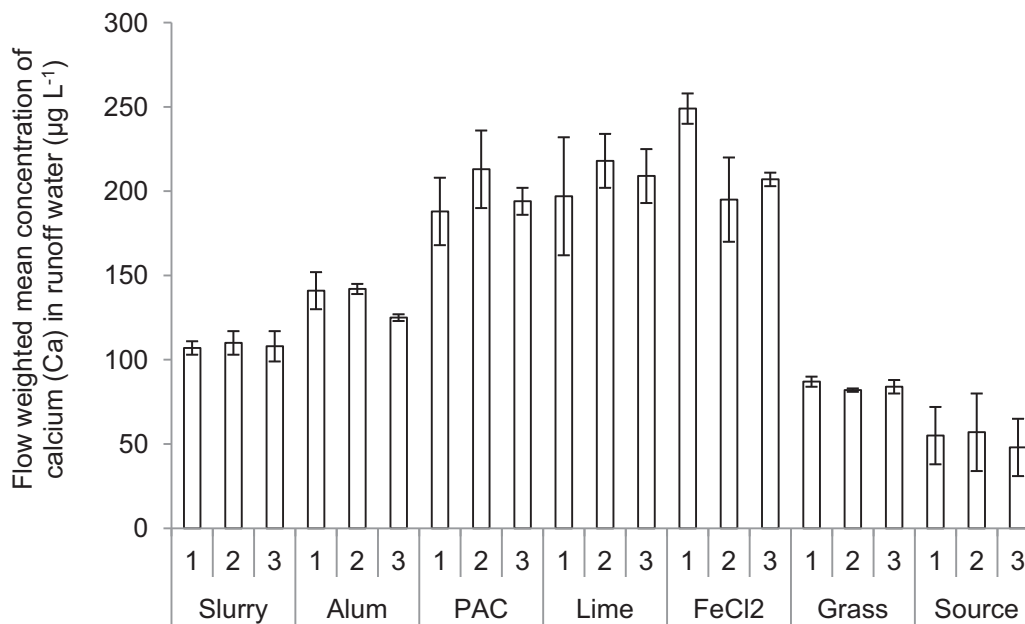

Figure 4.10 Average flow-weighted mean concentrations of Ca in runoff and rain water

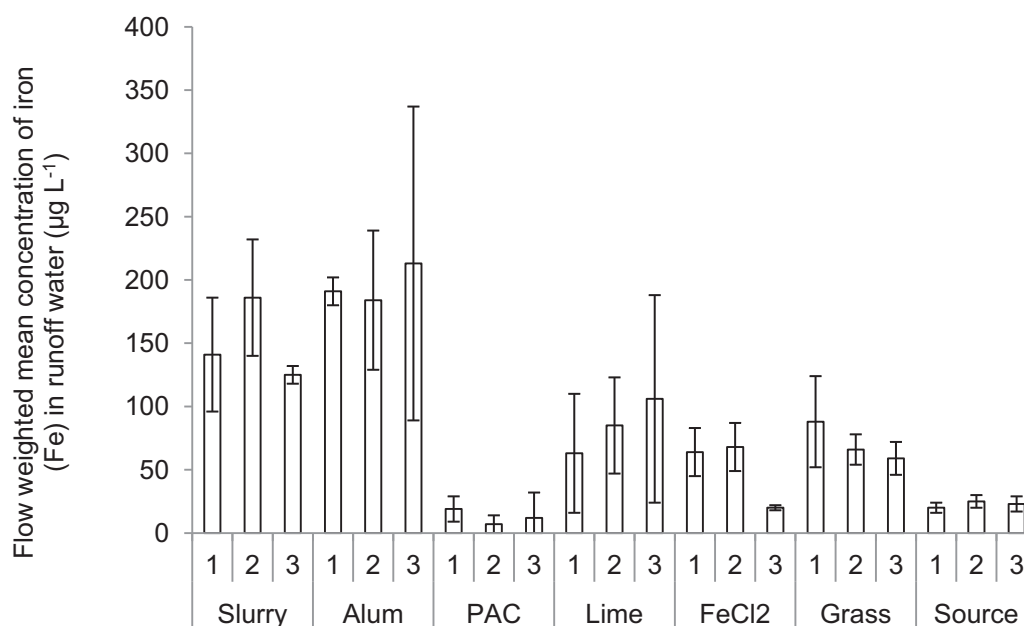

Figure 4.11 Average flow-weighted mean concentrations of Fe in runoff and rain water

4.5. Discussion

4.5.1. Slurry and amended slurry analysis

The amendments examined significantly reduced WEP in amended slurry compared to the control. This was in agreement with previous studies (Dao, 1999; Dou et al., 2003). Lefcourt and Meisinger (2001) reported a 97% reduction in WEP of dairy cattle slurry when 2.5% by weight of alum was added in a laboratory batch experiment. Dao and Daniel (2002) added alum (810 mg Al L⁻¹) and ferric chloride (810 mg Fe L⁻¹) (compared to 1250 mg Al L⁻¹ and 2280 mg Fe L⁻¹ in this study) to dairy slurry and observed that slurry WEP was reduced by 66 and 18%, respectively. At higher application ratios of metal-to-TP, this study showed that greater reductions in WEP are achievable.

The amendments also changed the pH of the slurry. Lime addition increased slurry pH significantly, resulting in a 25 and 30% reduction in NH₄-N and TN of slurry following amendment and mixing (Table 4.1). This was similar to findings of a study by Molloy

and Tunney (1983), who reported an increase in pH to 7.8 and a 50% increase in NH_3 loss when CaCl_2 was added to dairy slurry. This loss in $\text{NH}_4\text{-N}$ was most likely due to NH_3 volatilisation, as depending on the pH of a solution, $\text{NH}_4\text{-N}$ can occur as NH_3 gas or the ammonium ion (NH_4) (Gay and Knowlton, 2005). This reduces the fertiliser value of the slurry and increases NH_3 emissions from slurry. Addition of alum, PAC and FeCl_2 to dairy cattle slurry significantly reduced the pH, as expected. This phenomenon has been reported by a number of studies examining the use of amendments to reduce NH_3 losses from dairy cattle slurry (Meisinger et al., 2001; Shi et al., 2001). Meisinger et al. (2001) reported a 60% reduction in NH_3 loss from dairy cattle slurry when 2.5% by weight of alum was added in a laboratory batch experiment. In a field study, Shi et al. (2001) reported a 92% reduction in NH_3 loss. Moore and Edwards (2005) have shown that chemical amendment improves yields due to increased N efficiency. Chapter 5 examines the impact of amendments on gaseous emissions and the risk of ‘pollution swapping’, which must be considered when evaluating amendments for possible recommendations to legislators.

4.5.2. Water quality

The DRP and TP concentrations in runoff water from grass only treatment was well in excess of the MAC of $30 \mu\text{g DRP L}^{-1}$ (Flanagan, 1990) and $25\text{-}100 \mu\text{g TP L}^{-1}$ (USEPA, 1986) for fresh waterbodies.

This study reinforced the results of a micro-scale study (Chapter 3) at meso-scale and demonstrated that PAC is the most effective chemical amendment to reduce incidental DRP losses, with alum being most effective at reducing DUP, PP, TP and SS losses arising from land application of dairy cattle slurry. A limited number of runoff studies have been carried out with chemical amendment of dairy cattle slurry (Elliot et al, 2005; Torbert et al., 2005) and swine slurry (Smith et al., 2001a). Torbert et al. (2005) amended landspread composted dairy manure with ferrous sulphate, gypsum and lime (each at 3:1 metal-to-TP ratio) immediately prior to a 40-min rainfall event with overland flow equivalent to a rainfall intensity of 124 mm h^{-1} . Ferrous sulphate reduced DRP loss by

66.3%, while gypsum and lime amendments increased DRP loss compared to control. Lime and gypsum were effective for a short time at the beginning of the event and the authors recommended that lime could be used in areas with infrequent and low volume runoff events. In the Torbert et al. (2005) study, amendments were surface applied to slurry immediately after slurry application and just before the first rainfall simulation event occurred. The differences between the results are likely due to a combination of the shorter contact time with lime before the first rainfall event and less mixing due to different amendment application methods used in each study. In a plot study, Smith et al. (2001a) amended swine manure with alum and AlCl_3 at two stoichiometric ratios (0.5:1 and 1:1 Al: TP). Dissolved reactive phosphorus reductions for alum and AlCl_3 at the lower ratio were 33 and 45%, respectively, with 84% for both amendments at the higher ratio, which was similar to reductions observed in the current study.

The reductions in P losses in the present study were similar to the percentage reductions obtained in other incidental P loss mitigation studies. Hanrahan et al. (2009) reported that incidental TP and DRP losses were reduced by 89 and 65%, respectively, by delaying rainfall from 2 to 5 d after dairy cattle slurry application. This was in agreement with results of O'Rourke et al. (2010). In a plot study, McDowell and Sharpley (2002b) applied dairy cattle slurry at $75 \text{ m}^3 \text{ ha}^{-1}$ to the upper end of plots with lengths varying from 1 to 10 m. Increasing the distance from the location where dairy slurry was applied to the runoff water collection point was shown to reduce incidental P concentrations in overland flow by between 70 and 90% when plots were subjected to simulated rainfall with an intensity of 70 mm h^{-1} . Therefore, as there are less expensive methods which can achieve similar reductions in incidental P losses, in future the focus of chemical amendment studies must be to find amendments to bind P in soil with the aim of reducing long-term P losses.

In order to minimise the effect of the larger variation in the study control than in runoff from grass-only and amended slurry runoff boxes and to detect differences between treatments, the slurry-control was excluded from the statistical analysis of TP and PP. The reduction in TP and PP losses when alum, PAC and FeCl_2 was added to slurry was a

result of a combination of precipitation and floc formation, which led to a decrease in SS loss in runoff water. In the case of lime addition, the reductions were a result of the formation of Ca-P precipitates. The average FWMC of TP for the slurry-control during the three rainfall simulation events was 8,390 $\mu\text{g L}^{-1}$. This was similar to 7,000 $\mu\text{g L}^{-1}$ reported by Preedy et al. (2001) in a rainfall simulation study to examine incidental P loss from dairy slurry.

Measures such as increasing the time between slurry application and the first rainfall event are as effective as chemical amendment at reducing incidental losses of P. Chemical amendment immobilises soluble P in slurry applied to soil and could therefore be included as a low capital cost management tool to reduce farm P status and chronic P losses. The cost of chemical amendments in comparison to other treatment methods (e.g. transporting to other farms, AD, separation and composting) is likely to be the most significant factor in the future implementation of chemical amendments. Economies of scale were not considered in this study and this could considerably reduce costs. The cost of amendment, calculated after results of Chapter 3, based on the estimated cost of chemical, chemical delivered to farm, addition of chemical to slurry, increases in slurry agitation, and slurry spreading costs as a result of increased volume of slurry due to the addition of the amendments to slurry, is shown in Table 4.2. At the scale of the present study, alum and ferric chloride provide the best value in reducing on TP loss from slurry. These are preliminary estimates and if the cost of using these amendments as a mitigation measure is to be accurately calculated, then the optimum dosage for each amendment at field-scale needs to be determined.

4.5.3. Metals in runoff water

Previous studies (Moore et al., 1998; Edwards et al., 1999) have reported that chemical amendment of poultry litter posed no significant risk of increased metal release to runoff water. The findings of the present study also validate this for chemical amendment of dairy cattle slurry. Moore et al. (1998) associated an increase in Ca release from alum treatment to a displacement of Ca in Ca-P bonds by Al. This is also likely to be the cause

for PAC and FeCl_2 with Ca displaced by Al and Fe. The increase in Ca from the lime treatment was expected as a high rate of lime was applied. The FWMC of Fe (Figure 4.11) decreased for all treatments except alum, which increased Fe loss by 30% compared to the slurry-control; this was most likely a result of pH effect of alum, which increased the Fe solubility leading to higher Fe losses. There are acute (acute concentrations being short-term concentration and chronic being a long-term concentration) MAC ($750 \mu\text{g L}^{-1}$) and chronic MAC ($87 \mu\text{g L}^{-1}$) for Al in runoff (USEPA, 2009). The Al concentrations observed in the present study were below all MAC with the exception of slurry-control during RS2 and grass-only treatment in RS2, which exceeded chronic MAC. There is no MAC for Ca in water. Iron concentrations in runoff were all below the chronic MAC of $1,000 \mu\text{g L}^{-1}$ (USEPA, 2009).

From previous studies, adverse effects are not expected due to alum amendment to manure. In a plot study, Moore et al. (1998) amended poultry litter with alum to examine the effect of alum amendment on runoff concentrations of metals. Alum treatment significantly reduced Fe in runoff. Runoff Al concentrations were not affected by treatment and Ca concentrations increased after treatment. Moore et al. (2000) also found Al loss from a small-scale catchment was unaffected by alum treatment. In order to determine the effect of long-term additions of alum to poultry litter, Moore and Edwards (2005) began a 20-yr study in 1995. The most significant findings of this study were that long-term land application of alum-amended poultry litter did not acidify soil in the same way as $\text{NH}_4\text{-N}$ fertilisers and that Al availability was lower from plots receiving alum-treated poultry manure than $\text{NH}_4\text{-N}$ fertiliser. McFarland et al. (2003) incorporated alum into soil prior to application of dairy dirty water and reported no difference in Al concentrations in runoff between control and alum amended plots.

4.6. Conclusions

The results of this study demonstrate that chemical amendment was very successful in reducing incidental losses of DRP, TP, PP, TDP, DUP and SS from land-applied slurry. The results of the study demonstrate that PAC was the most effective amendment for

decreasing DRP losses in runoff following slurry application, while alum was the most effective for TP and PP reduction. Incidental loss of metals (Al, Ca and Fe) from chemically amended dairy cattle slurry was below the MAC for receiving waters. Future research must examine the long-term effect of amendments on P loss to runoff, gaseous emissions, plant availability of P and metal build-up in the soil. If amendments to slurry are to be recommended and adopted as a method to prevent P losses in runoff, the impact of such applications on slurry-borne pathogens, as well as pathogen translocation to the soil and release in surface runoff, needs to be addressed. The long-term effects on microbial communities in soil must also be examined. The results of this study show that even with chemical amendment, P concentration in runoff was above the MAC. Therefore, amendments may not be the best option for minimising incidental P losses, as timing of applications may be just as effective at controlling incidental P losses, and may be much more cost effective. However, chemical amendment immobilises soluble P in slurry and has the potential to reduce chronic P losses. The use of chemical amendments in combination with other mitigation methods such as grass buffer strips would likely increase the effectiveness of the measures. Future work should focus on using amendments to reduce P solubility in slurry to decrease P loss from high P soils by binding P in slurry once it is incorporated into the soil, thereby allowing farmers to apply slurry to soil without further increasing the potential for P loss.

4.7. Summary

The agitator test (Chapter 3) identified amendments with the best ability to reduce P solubility in dairy cattle slurry. Chapter 4 has shown that these amendments can effectively reduce all forms of P in runoff in realistic conditions. The next step is to examine these amendments at field-scale. However, before these amendments are examined at field-scale, there is a need to examine their impact on GHG and potential pollution swapping. Chapter 5 details the results of an experiment designed to examine GHG and pollution swapping. These results allow feasibility discussion (Chapter 3) to be developed further to include GHG and pollution swapping.

Chapter 5 Effect of chemical amendment of dairy cattle slurry on greenhouse gas and ammonia emissions

5.1. Overview

The previous two chapters examined the effectiveness and feasibility of amendments in reducing P solubility. This chapter considers the effect of chemical amendment of dairy cattle slurry on gaseous losses which, together with their impact on surface runoff, are critical in selecting most feasible amendments for recommendation to legislators.

5.2. Introduction

Organic manure is a valuable fertiliser resource in terms of N, P, K and micronutrients. Losses of N and P to both groundwater and the atmosphere not only act as significant sources of pollution, but can represent significant losses in terms of fertiliser value (Lalor, 2008). Whilst the efficacy of the various slurry amendments on P sequestration efficiency is well quantified (Dao, 1999; Lefcourt and Meisinger, 2001; Dao and Daniel, 2002; Dou et al., 2003; Chapters 2 and 4), there is less information on their effects on gaseous emissions and pollution swapping. This study will allow the feasibility ranking to be further refined to take account of GHG emissions and pollution swapping. An experiment was designed to facilitate the measurement of NH₃, N₂O, CH₄ and CO₂ emission following land application of dairy cattle slurry (Figure 5.1). Charcoal was included as an additional treatment as there is a large body of work involving biochars being carried out at present and there is the potential in their use for P mitigation and GHG control.

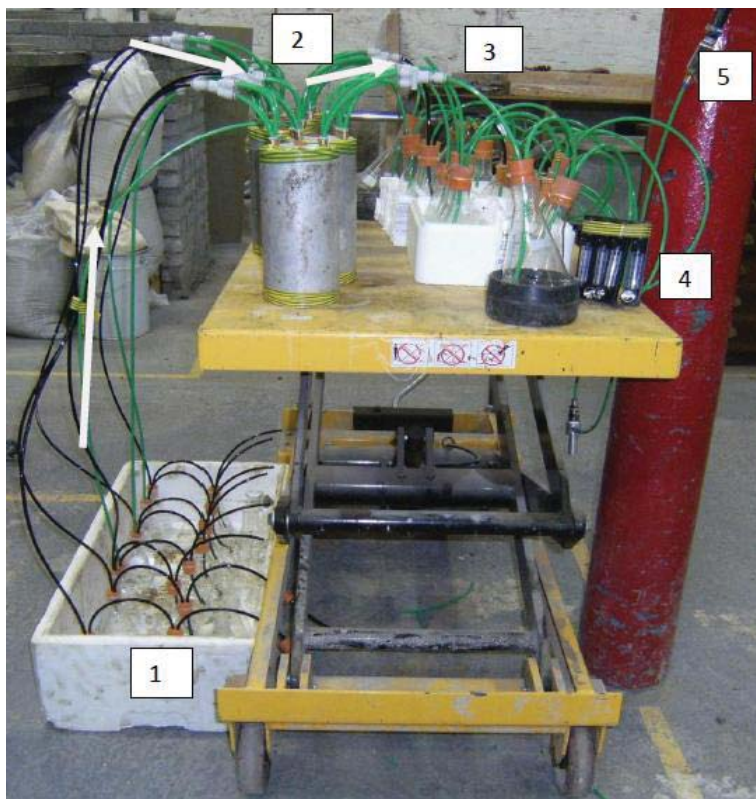

- 1 Air stripped of ammonia before entering dynamic chamber after Misselbrook et al. (2005)
- 2 Sealed dynamic chambers with air flowing continuously
- 3 Acid traps used to measure ammonia volatilisation after Misselbrook et al. (2005)
- 4 Flow meters used to measure and regulate flow throughout the study
- 5 Pump used to create vacuum to draw air over slurry in dynamic chambers

Figure 5.1 Photograph of dynamic chamber apparatus

5.3. Materials and Methods

5.3.1. Soil sample collection and analysis

Intact soil samples were collected from a dairy farm in Athenry, Co. Galway (53°21'N, 8°34' W). 120-mm-high, 100-mm-diameter Al coring rings were used to collect undisturbed soil core samples (n=18). Soil samples, taken to a depth of 100 mm below the ground surface from the same location, were air dried at 40°C for 72 h, crushed to pass a 2 mm sieve, and analysed for Morgan's P using Morgan's extracting solution (Byrne, 1979). Soil pH (n=3) was determined using a pH probe and a 2:1 ratio of deionised water-to-soil. Soil texture was determined by PSD (B.S.1377-2:1990a). Organic matter content of the soil was determined using the LOI test (B.S.1377-3; BSI, 1990b). The soil was a poorly-drained sandy loam (58% sand, 27% silt, 15% clay) with a Morgan's P of 22±3.9 mg P L⁻¹, a pH of 7.45±0.15 and an OM content of 13±0.1%.

Historic applications of organic P from an adjacent commercial sized piggery led to high STP in the soil used in this study.

5.3.2. Dairy slurry collection and analysis

Cattle slurry from dairy replacement heifers was taken from a dairy farm (53°21' N, 8°34' W) in County Galway, Republic of Ireland. Before sample collection, the storage tanks were agitated. Samples were transported to the laboratory in 10-L drums and stored at 4°C. Slurry and amended slurry pH was determined using a pH probe (WTW, Germany) and the WEP of slurry was measured at the time of land application after Kleinman et al. (2007). The TP of the dairy cattle slurry was determined after Byrne (1979). Potassium and Mg were analyzed using a Varian Spectra 400 Atomic Absorption instrument and analyses for N and P were carried out colorimetrically using an automatic flow-through unit. Ammoniacal nitrogen of slurry and amended slurry was extracted from fresh slurry by shaking 10g of slurry in 200 ml 0.1 M hydrochloric acid (HCl) on a peripheral shaker for 1 h and filtering through a No 2 Whatman filter paper.

5.3.3. Chemical amendment of slurry

The six treatments examined in this study, selected based on results of Chapter 3 and 4, were: slurry-only (the study control) and slurry amended with (1) industrial grade alum (8% Al₂O₃, Al₂(SO₄)₃.nH₂O) (2) industrial grade PAC (3) analytical grade FeCl₂ (4) lime (Ca(OH)₂) and (5) charcoal. With the exception of charcoal (analytical grade activated charcoal used as biochar can vary depending on material from which it is made), the amendments were applied at the following stoichiometric rates determined from Chapter 3: alum 1.11:1 (Al: TP); PAC 0.93:1 (Al:TP); FeCl₂ 2:1 (Fe:TP); and lime 10:1 (Ca: TP). Charcoal was applied at a rate equivalent to 3.96 m³ ha⁻¹. This corresponded to a rate above which DM of slurry would become too high to allow landspreading without adding water (Stan Lalor *pers com*, 2010). The amendments were added to the slurry and mixed rapidly using a blender immediately before simulated land application. A grass only background was also examined but values measured were very low compared to

emissions from slurry treated soil cores so these were excluded. Slurry and amended slurry were applied directly to the surface of the intact grassed soil at a rate equivalent to 26 kg TP ha⁻¹ (33 m³ slurry ha⁻¹). Immediately after application, the chambers were sealed and the air flow through the system was started and maintained for 168 h.

5.3.4. Measurement of ammonia

The dynamic chamber used in this experiment was based on a design used by Misselbrook et al. (2005). Eight chambers were connected in parallel (Figure 5.2). Air was drawn through the system via a vacuum pump, with air flow through each chamber regulated at 5.1 L min⁻¹. This was to ensure that the number of headspace exchanges per minute was such that the emission of NH₃ would not be affected by small differences in flow rates between chambers (Kissel et al., 1977).

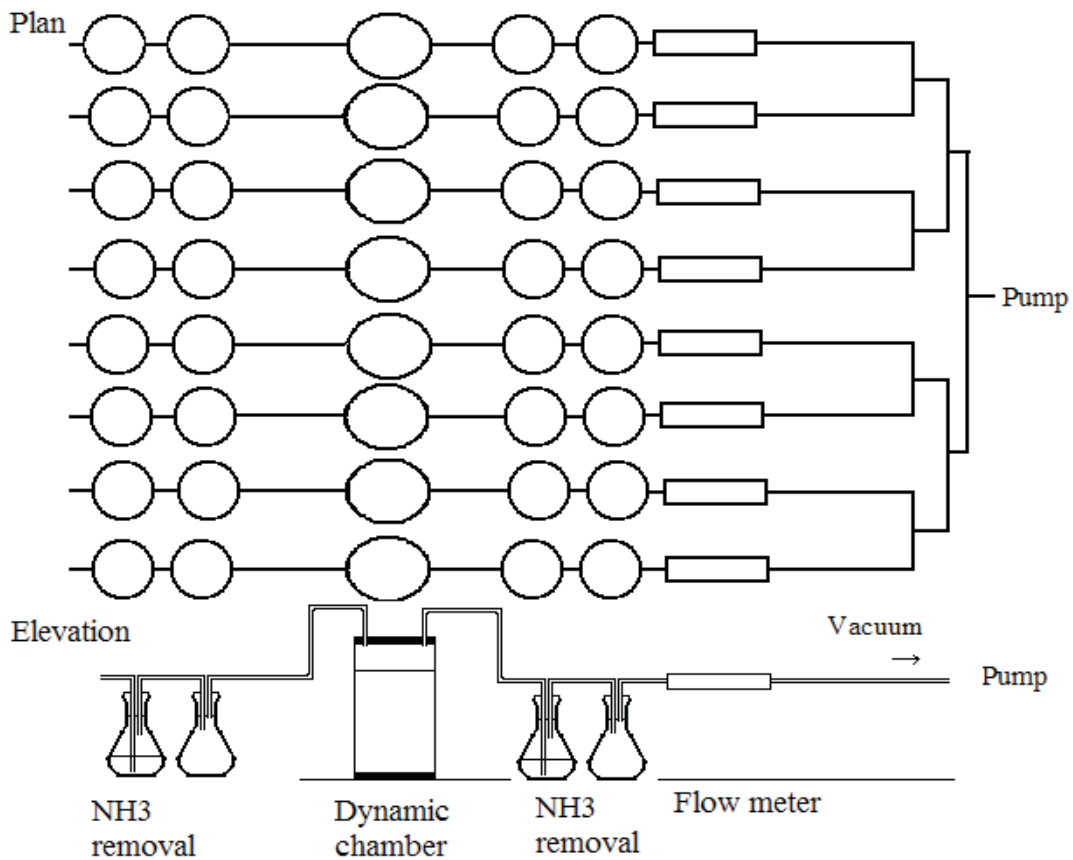

Figure 5.2 Diagram of apparatus used to measure ammonia emissions

Prior to entering each chamber, the ammonia contained in the ambient air was immobilised using an acid trapping method. The air was drawn over the soil surface using a vacuum pump (VTE 10 VACCUM PUMP, Irish Pneumatic Service LTD, Ireland) and gas mass flow meters were used to regulate and measure air flow (Cole-Parmer, Hanwell, UK).

The chambers comprised the same 200-mm-diameter Al cores used to collect the grassed soil samples, fitted with a polypropylene lid and base (Figure 5.3). The samples were saturated for 48 h and then allowed to drain for 48 h. During this time, the surfaces were covered to avoid evaporation losses. After approximate field capacity was achieved, the chambers were sealed at the base using silicon grease to ensure an air-tight seal. Each treatment was applied to the grassed-soil surface and a lid was fitted to each chamber. Each chamber had four inlet and outlet ports to ensure good mixing of air within the chamber (after Misselbrook et al., 2005). During the dynamic phase, the cores were attached to the dynamic chamber for 168 h. During this time, air was drawn through the chambers over the surface of the treated soil and through acid traps, which were used to measure NH_3 .

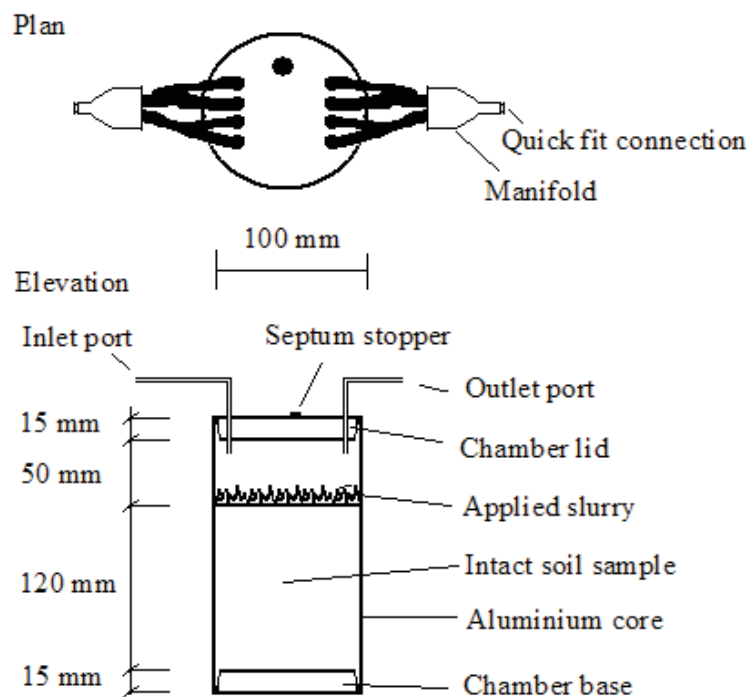

Figure 5.3 Dynamic chamber

5.3.5. Measurement of CH₄, N₂O and CO₂

Air samples were drawn from the head space of the ammonia volatilisation chamber (AVC) and analysed for CH₄, CO₂ and N₂O using a photo-acoustic-analyser (PAA; INNOVA 1412, Lumasense Inc, Denmark) (Figure 5.4). The majority of NH₃ volatilisation arising from spreading of slurry occurs in initial 48 h after spreading (Gary Lanigan *pers com*, 2011), while N₂O and CH₄ losses take place over a much longer time period (Gary Lanigan *pers com*, 2011). Therefore, it was only necessary to use the AVC for the first 168 h and then continue CH₄, CO₂ and N₂O sampling for a further 10 d. During the first 168 h (during which time NH₃ was measured), the chamber was disconnected from the AVC apparatus and the inlet and outlets were connected to the PAA for 6 min at t = -1 (1 h before treatment), 0, 2, 6, 24, 48, 72, 96, 144, 168. After 168 h, NH₃ measurement was discontinued and the AI cores, containing intact soil samples, were removed from the apparatus and incubated in the laboratory. During this time, a portable cap was fitted to each chamber and the PAA was used to measure fluxes at t = 9, 11, 13, 15 and 17 d. The mass of the sample, and therefore water content, was kept constant throughout the experiment by periodically adding deionised water to the surface of the soil samples.

5.3.6. Statistical analysis

Data (Appendix D) were checked for normality and homogeneity of variance by histograms, qq plots, and formal statistical tests as part of PROC UNIVARIATE procedure of SAS (SAS, 2004). The data were analysed using the PROC GLM procedure (SAS, 2004). The linear model included the fixed effects of treatment and, with the exception of slurry pH, CH₄ and CO₂, data were logarithmically transformed prior to analysis. A multiple comparisons procedure (Tukey) was used to compare means.



Figure 5.4 Photograph of PAA during carbon dioxide, methane and nitrous oxide measuring period

5.4. Results

5.4.1. Slurry and amended slurry results

The slurry had TN of $4430 \pm 271 \text{ mg L}^{-1}$, TP of $1140 \pm 76 \text{ mg L}^{-1}$, TK of $4480 \pm 218 \text{ mg L}^{-1}$ and a pH of 7.5 ± 0.05 . The slurry TP and TK remained relatively constant, while the WEP was lowered significantly by all chemical amendments (Table 5.1). Alum, FeCl_2 and PAC addition reduced slurry pH from approximately 7.5 to 5.4, 6.7, and 6.4, respectively ($p < 0.005$). The pH of alum-amended slurry was significantly different to all other treatments, while FeCl_2 and PAC were not significantly different to each other. Addition

of lime increased slurry pH to 12.2 ($p<0.001$), while charcoal did not have a significant effect on slurry pH.

Table 5.1 Dairy cattle slurry and amended dairy cattle slurry properties

Treatment	DM (%)	pH	WEP (g/kg DM)
Slurry-control	10.5 (0.04)	7.5 (0.05)	1.81 (0.112)
Alum	9.4 (0.16)	5.4 (0.12)	0.008 (0.002)
Lime	8.2 (0.29)	12.2 (0.12)	0.014 (0.001)
FeCl ₂	10.1 (0.22)	6.7 (0.06)	0.017 (0.001)
PAC	9.6 (0.28)	6.4 (0.05)	0.011 (0.002)
Charcoal	12.57 (0.45)	7.3 (0.4)	1.78 (0.23)

(Standard deviation in brackets)

5.4.2. Ammonia

Alum ($p<0.001$), FeCl₂ ($p<0.005$), PAC ($p<0.005$) and charcoal ($p<0.01$) reduced NH₃ emissions by 92, 54, 65 and 77% compared to the slurry-control, while lime increased emissions by 114% ($p<0.001$). Lime amendment resulted in the loss of 84% of TAN applied. Alum, PAC, FeCl₂ and char were not statistically different to each other. The NH₃ emissions from untreated and chemically amended slurry, expressed as a percentage of TN and NH₄-N in the applied slurry, are shown in Figure 5.5.

Ammonia release from slurry for all treatments followed a Michaelis-Menten response curve, with the majority of emissions occurring within the first six hours following application. With the exception of the lime treatment, chemical amendment of slurry prior to land application increased the time for half of ammonia losses to occur ($T_{0.5}$). Alum ($p<0.005$), FeCl₂ ($p<0.05$), PAC ($p<0.006$) and charcoal ($p<0.05$) increased $T_{0.5}$, compared to the slurry-control, from 1.5 to 4.1, 3.5, 4.3 and 3.4 h, respectively ($p<0.05$). The $T_{0.5}$ of lime-amended slurry was not significantly different to the slurry-control. Cumulative ammonia release from untreated slurry was 40% of TAN.

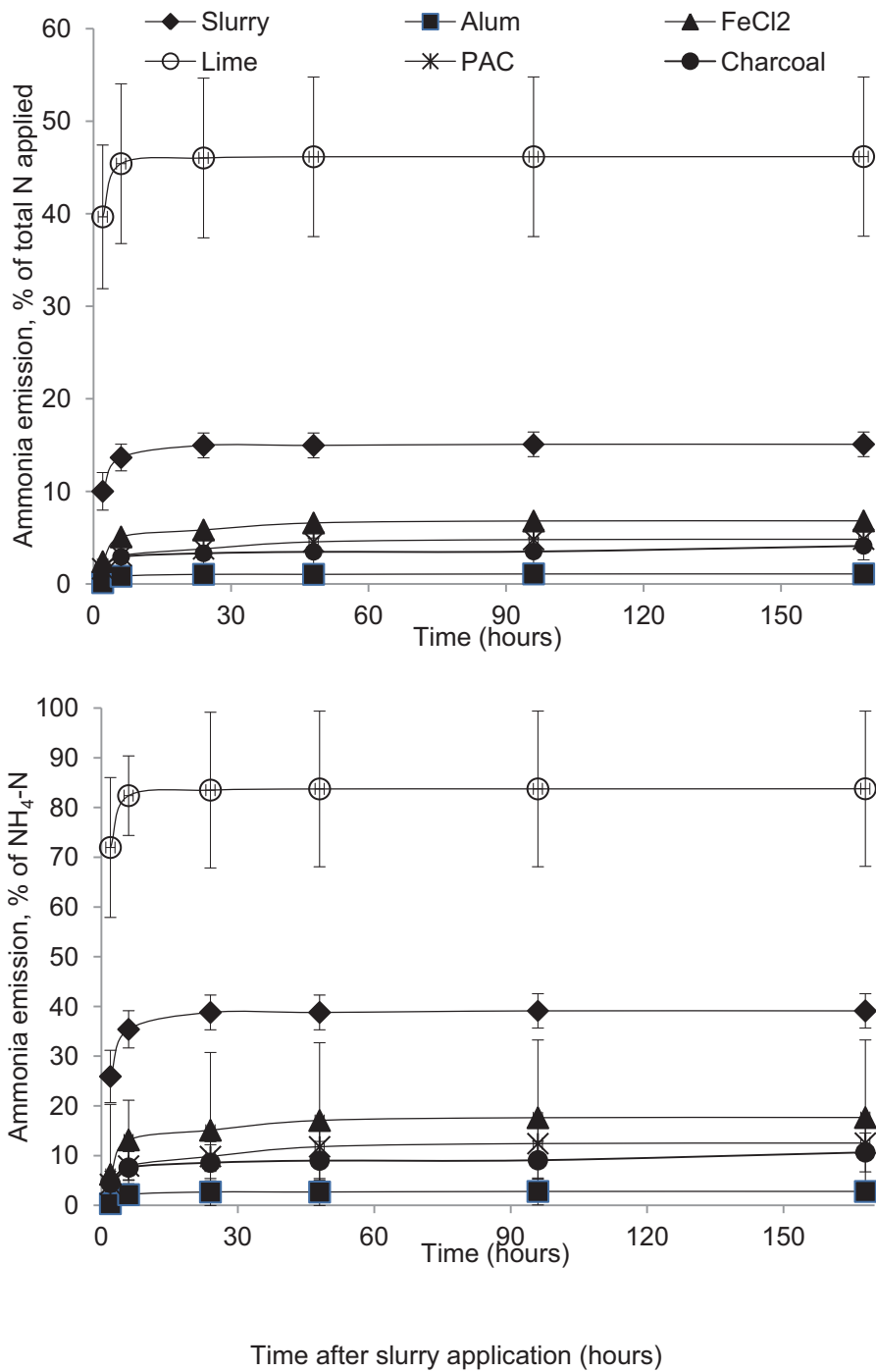

Figure 5.5 Cumulative ammonia emissions from untreated and chemically amended slurry expressed as a percentage of total nitrogen in slurry and ammoniacal nitrogen in slurry

5.4.3. Nitrous oxide

Cumulative N₂O emissions of dairy cattle slurry increased when amended with alum ($p<0.2$) and FeCl₂ ($p<0.2$) by 202 and 154 % compared to the slurry-control. Lime ($p<0.5$), PAC ($p<0.01$) and charcoal ($p<0.01$) resulted in a reduction of 44, 29 and 63% in cumulative direct N₂O loss compared to the slurry-control.

In this study, nitrous oxide emissions following land application of dairy cattle slurry were observed to increase from 0.18 g N₂O-N ha⁻¹ h⁻¹ to a peak of 4 g N₂O-N ha⁻¹ h⁻¹ at 24 h post application (Figure 5.6). Emissions of N₂O from alum were similar in magnitude and temporal dynamics to those from the slurry-control. Ferric chloride addition resulted in no increase in N₂O emissions until the 72 h sampling event, and a peak flux of 4.7 g N₂O-N ha⁻¹ h⁻¹ was measured at 96 h. Lime, PAC and charcoal addition resulted in much lower emissions, with peak emissions occurring after 24-48 h.

5.4.4. Carbon dioxide

In general, addition of amendments to slurry did not significantly affect soil CO₂ release during the study (Figure 5.7), with cumulative emissions for the period ranging from 320 – 380 kg CO₂ ha⁻¹ (Figure 5.8). However, significant reductions in CO₂ efflux were observed upon charcoal addition, with an 84% reduction in cumulative CO₂ emissions observed ($p<0.05$).

Immediately following land application of dairy cattle slurry and chemically amended slurry, there was generally a peak in CO₂ emissions followed by a steady release for the duration of the study. The lime amended slurry behaved differently to the other treatments and the slurry-control, and acted as a CO₂ sink immediately after land application. However, the cumulative emissions were similar to PAC and FeCl₂ treated slurry.

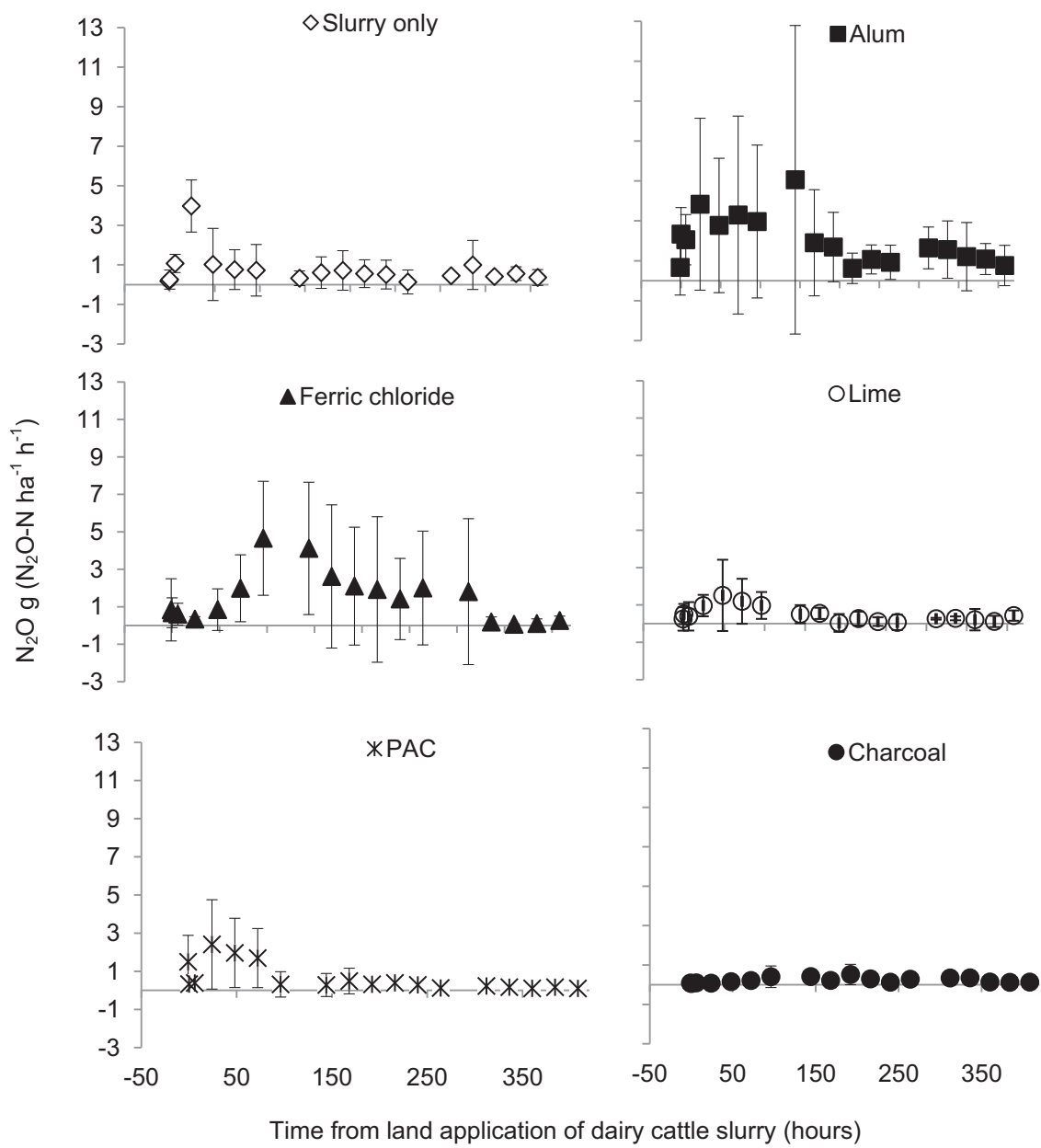

Figure 5.6 Nitrous oxide emissions from slurry and amended slurry in chambers (Mean ± standard error)

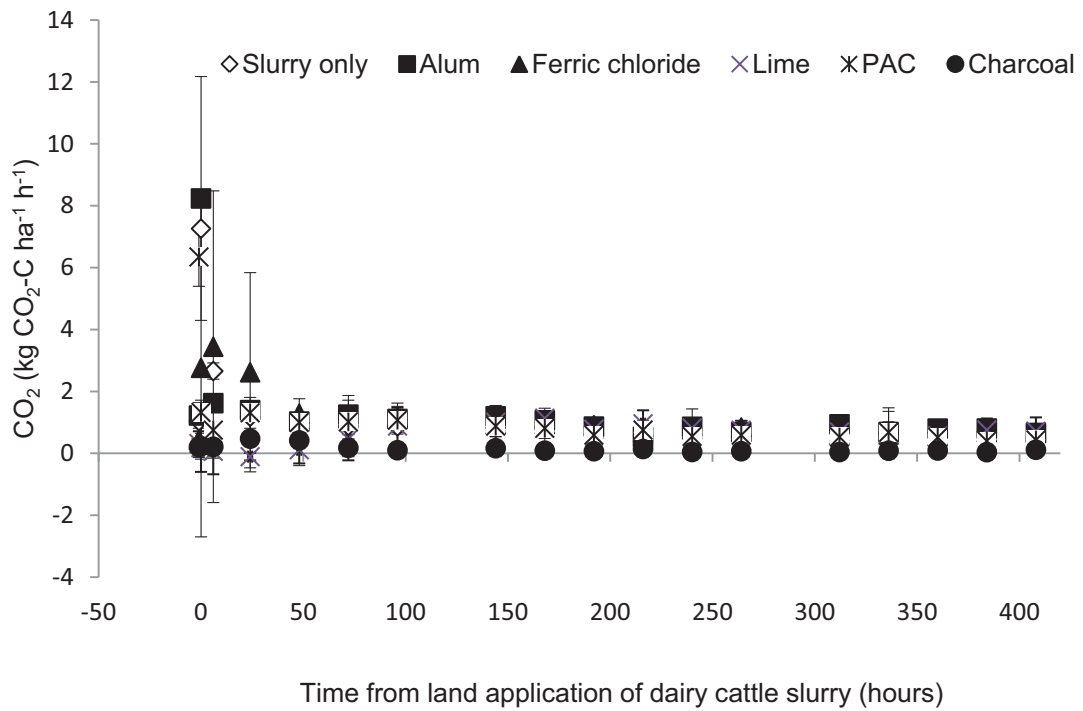

Figure 5.7 Carbon dioxide emissions from slurry and amended slurry in chambers. (Mean ± standard error)

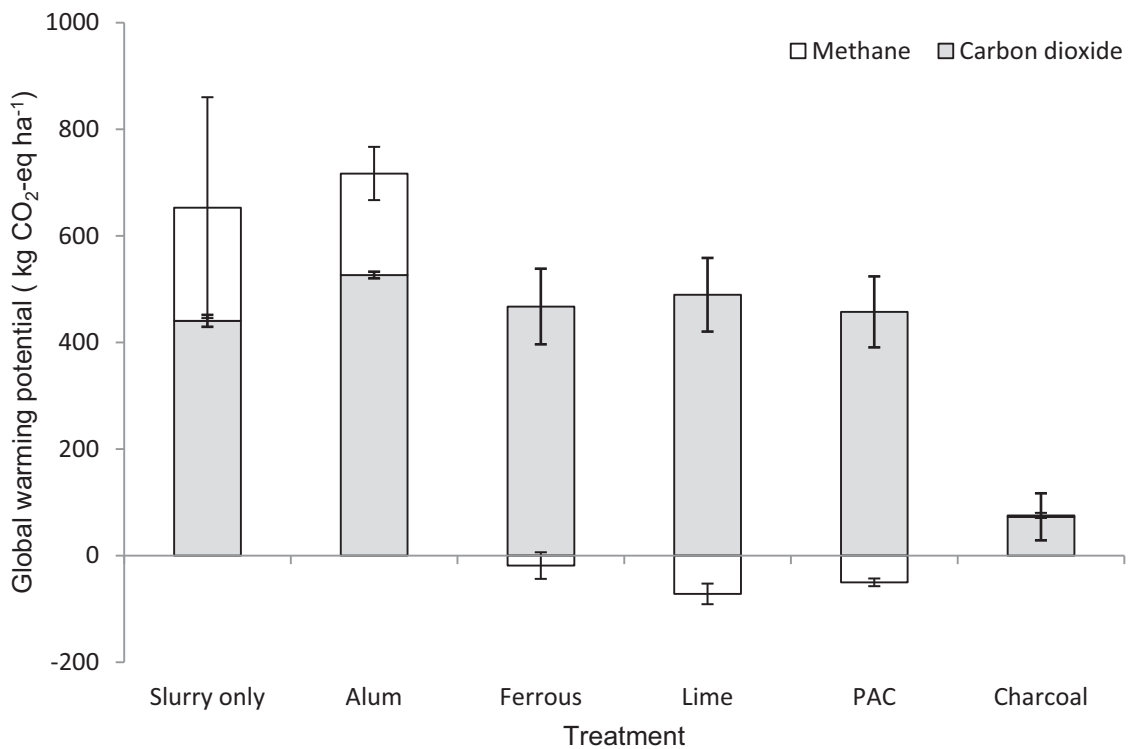

Figure 5.8 Cumulative carbon dioxide emissions from chambers for duration of study. (Mean ± standard error)

5.4.5. Methane emissions

Methane emissions increased from $-0.18 \text{ g CH}_4\text{-C ha}^{-1} \text{ h}^{-1}$ to $94 \text{ g CH}_4\text{-C ha}^{-1} \text{ h}^{-1}$ upon application of dairy cattle slurry (Figure 5.9). These levels decreased rapidly to approximately $7 \text{ g CH}_4\text{-C ha}^{-1} \text{ h}^{-1}$ by 48 h and remained relatively constant until the 312 h sampling event. Following this, methane losses were much more variable. There was a similar trend for all of the amended slurries applied with an initial increase in losses followed by a rapid decrease and then steady release for the duration of the study. All of the amendments examined reduced the initial peak in CH_4 emissions compared to the slurry-control ($p < 0.0001$). Lime ($p < 0.05$), PAC ($p < 0.08$) and FeCl_2 ($p < 0.09$) reduced cumulative CH_4 emissions compared to the slurry-control by 134, 121 and 99%, respectively. Alum, charcoal and the slurry-control were not significantly different to each other.

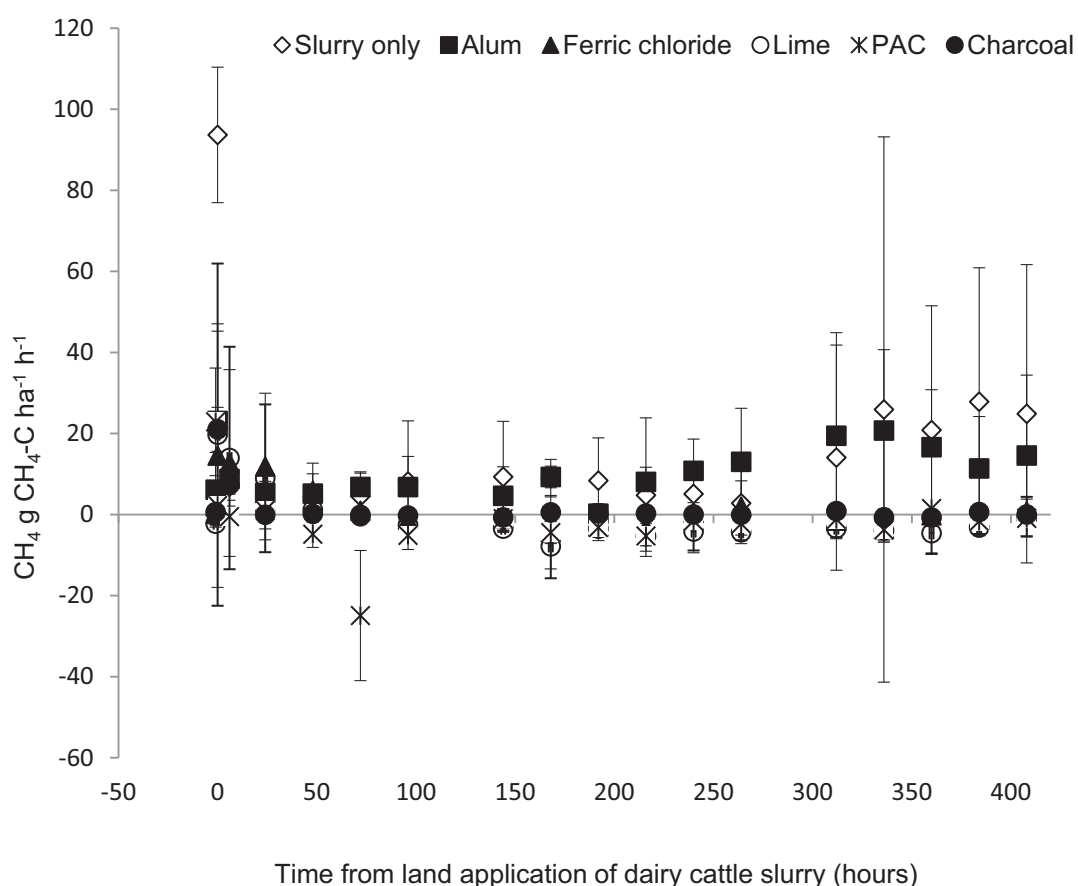

Figure 5.9 Methane emissions from slurry and amended slurry in chambers. (Mean \pm standard error)

5.4.6. Impact of amendments on global warming potential

Chemical amendment of dairy cattle slurry has been proposed as a possible P mitigation measure for the control of P solubility in dairy cattle slurry (Chapters 3 and 4). In order to assess the pollution swapping potential of the treatments, all emissions were expressed in CO₂ equivalents. Cumulative direct and indirect N₂O emissions from slurry and amended slurry in the chambers during the study are shown in Figure 5.10.

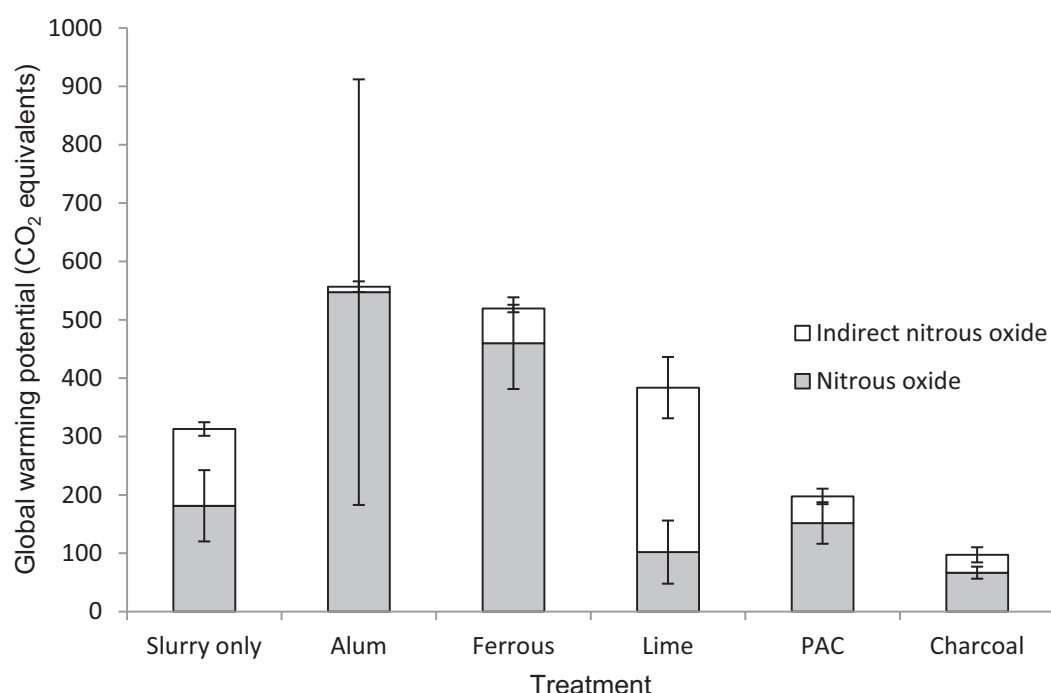

Figure 5.10 Nitrogen cumulative emissions (Nitrous oxide and indirect emissions resulting from ammonia losses) expressed in CO₂ equivalents. (Mean ± standard error)

Indirect N₂O emissions were calculated based on the assumption that all the NH₃ would be re-deposited within a 2 km radius of the point of application, which allowed use of an emission factor of 1% (IPCC, 2006). Alum, FeCl₂, lime and PAC have no significant effect on the sum of the cumulative direct and indirect N₂O emissions, while charcoal reduced total N₂O emissions from by 69% compared to the slurry-control ($p < 0.01$). The total N₂O emissions from charcoal treated slurry – with the exception of PAC - were

statistically different to slurry ($p<0.01$), alum ($p<0.01$), FeCl_2 ($p<0.001$), lime ($p<0.001$) treatments. Cumulative carbon dioxide and methane emissions are shown in Figure 5.8. Charcoal reduced total cumulative CO_2 and CH_4 emissions compared to the control ($p<0.001$) and was significantly different to alum ($p<0.001$), FeCl_2 ($p<0.05$), lime ($p<0.01$) and PAC ($p<0.05$). All gases measured have been expressed in CO_2 equivalents and are plotted in Figure 5.11. Amendment of slurry with charcoal significantly reduces greenhouse warming potential (GWP) following land application of dairy cattle slurry ($p<0.001$). In this study, there was no significant effect of any amendment of slurry on GWP caused by land application of dairy cattle slurry, with the exception of charcoal.

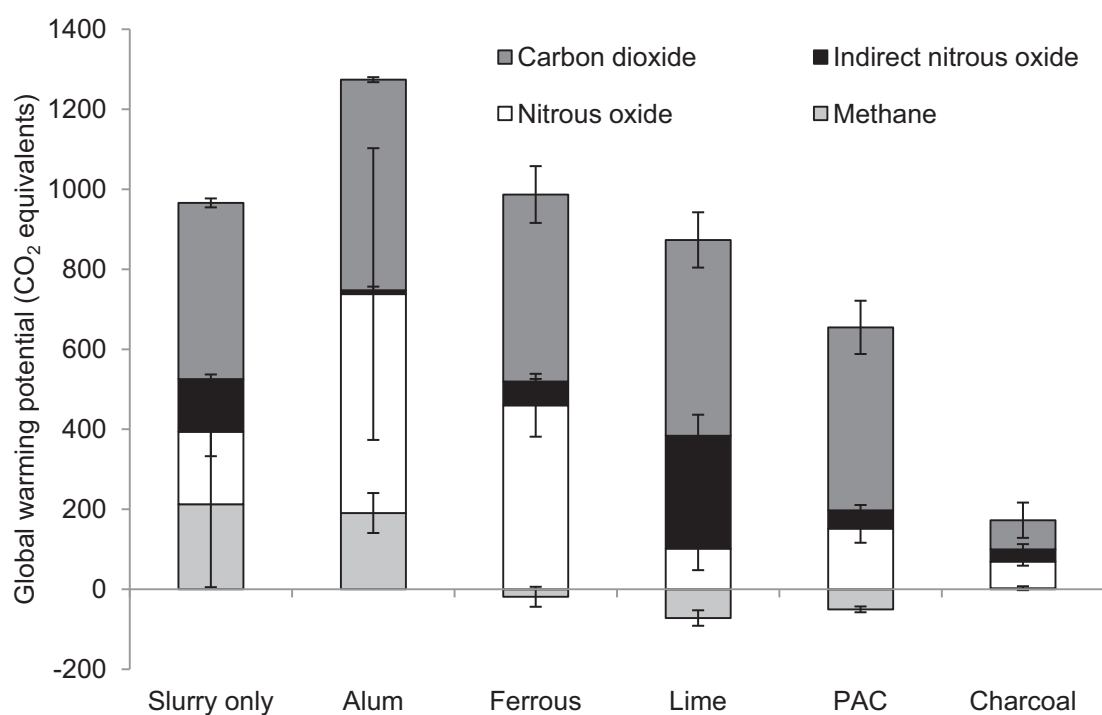

Figure 5.11 Cumulative carbon dioxide (CO_2), indirect nitrous oxide (N_2O), direct N_2O and methane (CH_4) measured during the study expressed in CO_2 equivalents. (Mean \pm standard error)

5.5. Discussion

5.5.1. Ammonia emissions

Ammonia volatilisation from dairy cattle slurry following land application is controlled by: humidity, temperature, wind speed at the time, method of application, and the degree of infiltration of the slurry into the soil (Søgaard et al., 2002, Sommer et al., 2003, Sommer et al., 2006). In addition, slurry pH, DM and TAN content greatly influence the rate and amount of NH₃ volatilisation (Smith et al., 2000; Misselbrook et al., 2000; Meisinger et al., 2001). It is estimated that between 60-80% of TAN applied can be lost during broadcast land spreading of cattle slurry, particularly during the first 12 h post application (Pain et al., 1989, Hyde et al., 2003). In the present study, cumulative NH₃ loss from land applied dairy cattle slurry was 22.6 kg NH₃-N ha⁻¹, with approximately 39% of NH₄-N applied lost in initial 24 h; this was equivalent to 15% of TN applied.

With the exception of lime, all amendments used reduced NH₃ losses compared to the slurry-control. This reduction was expected as chemical amendments, such as alum, have been used extensively in the USA to reduce NH₃ emissions from poultry litter (Moore et al., 1999) and from dairy cattle slurry (Table 5.2). Meisinger et al. (2001) reported a 60% reduction in NH₃ loss from dairy cattle slurry when 2.5% by weight of alum was added in a laboratory batch experiment. In a field study, Shi et al. (2001) reported a 92% reduction in NH₃ loss. The results of the present study were in agreement with previous findings for alum, PAC and FeCl₂, and the ammonia abatement by alum, PAC and FeCl₂ was primarily due to reductions in pH (ie. N was held in the ammonium form).

The large reductions in ammonia emissions associated with charcoal addition (74%) may have been due to both ammonia gas and ammonium ion adsorption, as biochar can act as a cation exchange medium (Asada et al., 2002). During pyrolysis of woody material for biochar production, thermolysis of lignin and cellulose occurs, exposing acidic functional groups, such as carboxyl groups. This has been shown to result in an 80-100% removal efficiency for ammonia gas (Oya and Iu, 2002; Iyobe et al., 2004). Biochar addition

during the composting of poultry litter reduced ammonia losses by 64%, even though pH increased (Steiner et al., 2010). As a result, the mechanism was thought to be due to the adsorption of ammonium ions as opposed to the immobilization of ammonia (Steiner et al., 2008). In addition, biochar has also been found to reduce N leaching by 15% due to adsorption of the ammonium ion predominantly by cation exchange (Ding et al., 2011).

Table 5.2. Summary of amendments used to reduce ammonia emissions in previous studies

Reference	Chemical	Amount added to slurry	Slurry type	Study type	% NH ₃ reduction	pH slurry	Comments
Meisinger et al. (2001)	alum	2.5% (w/w)	Dairy	Lab	60	4.5	Simulated storage experiment
	zeolite	6.25% (w)			55	7.8	
Kai et al. (2007)	H ₂ SO ₄	5 kg m ⁻³	Swine	Field	70	6.3	Farm scale storage and application
Smith et al. (2001a)	Alum	0.75% (v/v)	Swine	Plot	52		6-week study
Molloy and Tunney, (1983)	FeSO ₄	0.8 g to 25 g	Dairy	Batch	81		Batch scale experiment
	MgCl ₂	0.8 g to 25 g			23		
	CaCl ₂	0.8 g to 25 g			50	7.8	
Shi et al. (2001)	Alum	4500 kg ha ⁻¹	Dairy	Field	92	5.98 ^a	Applied to surface of feedlot
	CaCl ₂	4500 kg ha ⁻¹			71	6.99 ^a	
Husted et al. (1991)	HCL	240 m Eq	Dairy		90		
	CaCl ₂	300 m Eq		Lab	15		

^apH referred to is the pH of soil and slurry mixture

Lime increased slurry pH to 12.2 and increased the NH₃ loss compared to the slurry-control. Molloy and Tunney (1983) reported an increase in pH to 7.8 and a 50% decrease in NH₃ loss when CaCl₂ was added to dairy cattle slurry. This suggests that, although there may be potential to reduce NH₃ loss using Ca-compounds such as lime, it is not feasible at application rates high enough to reduce P solubility in dairy cattle slurry. There was a linear relationship between slurry pH at time of application and NH₃ loss from slurry and amended slurry in this study ($R^2=0.86$) (Figure 5.12). This would indicate that the change in slurry pH was the main process responsible for the reduction in NH₃ loss from dairy cattle slurry. In addition, there was a significant relationship ($R^2=0.98$) between slurry pH at the time of application and the log of the T_{0.5} (Figure 5.12). This

would indicate that if large NH_3 losses do not occur in the short-term after land spreading, the potential for loss is significantly reduced i.e. chemical treatments are not just delaying NH_3 loss, but mitigating it completely.

In addition to environmental problems caused by NH_3 losses, such losses reduce the nutrient value of the fertiliser and increase NH_3 emissions from slurry. The value of N lost via ammonia and N_2O emissions from the slurry-control for the duration of the study amounted to approximately €0.63 per m^3 slurry applied based on cost of €1.10 per kg N (Stan Lalor *pers com*, 2011). Alum, FeCl_2 , PAC and charcoal increased the fertiliser value of slurry by €0.56, €0.32, €0.41 and €0.48 per m^3 of slurry compared to the slurry-control.

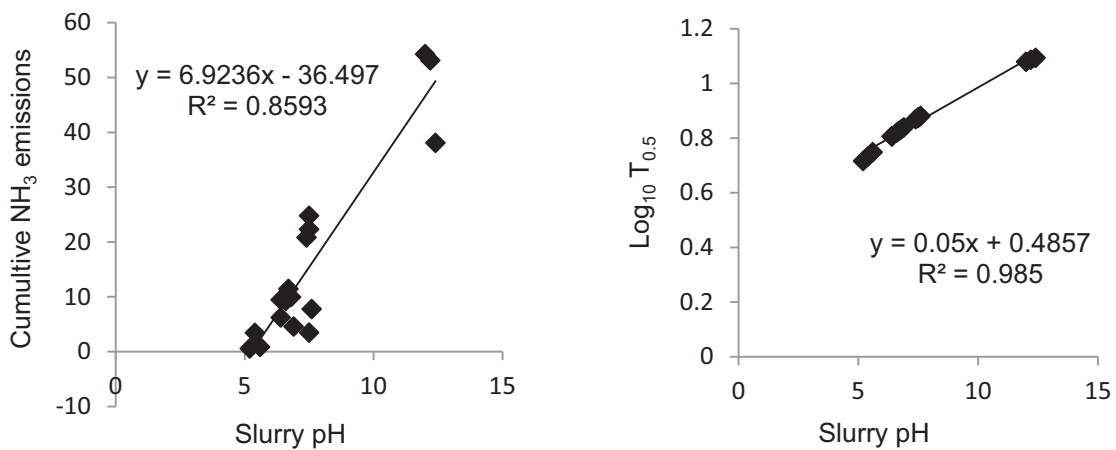

Figure 5.12 Relationship between slurry and amended slurry pH at time of application and (a) cumulative NH_3 emissions and (b) and log of time for half of ammonia emissions to occur ($T_{0.5}$)

5.5.2. Nitrous oxide

Land application of agricultural wastes results in an increase in N_2O emissions from soil (Velthof and Oenema, 1997). Nitrous oxide is of environmental importance as it contributes to global warming and the depletion of the ozone layer. It is produced by nitrification and denitrification processes. Nitrous oxide emissions are influenced by: soil

moisture status, soil temperature; soil nitrate content and organic carbon content (Velthof et al., 2002). It was hypothesised that any reduction in NH_3 loss would result in a concomitant increase in N_2O in soil due to higher soil N available for nitrification/denitrification. Alum amendments were shown to double cumulative N_2O losses compared to the slurry only treatment, whilst lime addition resulted in a decrease in N_2O emissions. Although N_2O emissions of the treatments examined were not significantly different to the control, alum and charcoal were significantly different to each other ($p < 0.01$). The low direct N_2O losses associated with lime addition were merely due to the fact that most of the available mineral N had been already lost during volatilisation. Ammonia volatilisation can also lead to indirect N_2O emissions as the majority of ammonia volatilised in the field is re-deposited within 2 – 5km *via* wet and dry deposition, and a proportion (1%) is re-emitted as N_2O (IPCC, 2006). When these indirect losses were calculated, lime addition accounted for an increase in indirect N_2O emissions from 283 g N_2O ha⁻¹ for the slurry-control to 606 g N_2O ha⁻¹. These results highlight the need to account for all gaseous N losses as an analysis of ammonia or N_2O in isolation would give skewed results.

In terms of abating total N emissions, biochar was the most effective amendment reducing total N_2O losses by 63%. There is currently sparse information on the effect of biochar on N_2O emissions. Some laboratory studies have indicated that biochar may reduce N_2O by increasing soil aeration and hence reduce water-filled pore space (Yanai et al., 2007). Alternatively, if pH is increased upon charcoal addition, this may induce a shift towards total de-nitrification to N_2 , thus reducing N_2O (Clough and Condron, 2010).

5.5.3. Carbon emissions

The majority of amendments had little effect on soil CO_2 respiration, demonstrating that the amendments neither stimulated nor retarded soil microbial processes. The reduction in CO_2 emissions associated with charcoal was surprising considering that a C source was added. Previous studies on charcoal application to organic manures have shown an

increase in C emissions in the short-term (Steiner et al., 2010), while biochar addition to soils have also indicated a simulation of soil microbial respiration (Wardle et al. 2008).

After land application, CH₄ emissions are of minor importance compared to NH₃ and N₂O emissions (Wulf et al., 2002a, b). Methane is produced mainly by microbial decomposition of OM under anaerobic conditions. The highest efflux was for untreated slurry and alum, immediately post manure application would indicate CH₄ formation during manure storage, as there would not be sufficient time for its formation in the soil. It is produced during slurry storage and shortly after slurry application, after which time the OM is oxidised to CO₂ and H₂O as aerobic conditions prevail. Initial CH₄ emissions in the following few hours most likely originate from CH₄ contained in the manure diffusing from the viscous layer, while subsequent emissions were likely to be produced during the degradation of labile carbon compounds (Chadwick et al., 2000; Sherlock et al., 2002). Kasimir-Klemedtsson et al. (1997) reported similar base-line CH₄ soil emission levels of 1.1 kg CH₄-C ha⁻¹ day⁻¹ (3.01 g CH₄-C ha⁻¹ day⁻¹) from Swedish cereal cropped soils, while Rodhe et al. (2006) recorded similar peak CH₄ emissions of approximately 75 g CH₄-C ha⁻¹ day⁻¹ immediately post application of cattle slurry to grassland. Chadwick and Pain (1997) also reported high emission levels following pig and dairy manure application to grassland soil in laboratory experiments.

5.5.4. Impacts of pollution swapping

Chemical amendment of dairy cattle slurry provides an opportunity to immediately reduce P solubility in dairy cattle slurry and could be included as a low capital cost management tool to reduce P solubility in manure and reduce farm P status in the short-term, as other management practices come into effect. This study allows for the effect of chemical amendment on gaseous emissions to be incorporated into the feasibility analysis of Chapter 3. The ranking system, determined in Chapter 3, was based on effectiveness, efficiency, potential barriers to use and cost of implementation. A new feasibility analysis was developed to include the results of this study and to give recommendations for the best amendment to mitigate DRP losses with the least potential for pollution swapping.

The results of this feasibility analysis are shown in Table 5.3. Charcoal was excluded as there is insufficient data on P sequestration potential to date. In order of decreasing feasibility, the amendments were ranked from best to worst as follows: PAC, alum, FeCl₂ and lime. Therefore, the amendments selected for recommendation for further study are, from best to worst: PAC, alum and lime. Ferric chloride was excluded due to risk of stability of Fe-P bonds in soil. Although there are similar concerns with lime, it is currently added to soil in Ireland to reduce acidity in soils and for this reason, it was decided to recommend lime over FeCl₂.

Table 5.3 Summary of feasibility of amendments (Adapted from Chapter 3). Marks for feasibility and pollution swapping are from 1 to 5. 1 = best 5 = worst.

Chemical	Ratio used Chapter 3	Feasibility score P	Pollution swapping	Combined feasibility	Notes
Alum	0.98:1 Al: P	1	5	6	Risk of effervescence Risk of release of H ₂ S due to anaerobic conditions and reduced pH Cheap and used widely in water treatment
AlCl ₃ (PAC)	0.98:1 Al: P	2	2	4	Reduced ammonia emissions No risk of effervescence (Smith et al., 2004) AlCl ₃ increased handling difficulty Expensive
FeCl ₂ (FeCl ₃)	2:1 Fe: P	3	4	7	Reduced ammonia emissions Potential for Fe bonds to break down in anaerobic conditions Increased release of N ₂ O
Ca(OH) ₂	5:1 Ca: P	4	3	7	Reduced ammonia emissions Increased NH ₃ loss Strong odour Hazardous substance
Charcoal			1		Potential to reduce P solubility limited work to date Improve soil microbial health Reduced GHG emissions Reduced ammonia emissions

5.6. Conclusions

This study showed that P mitigating amendments can result in pollution swapping. The amendments selected for recommendation for further study are, from best to worst, PAC,

alum and lime. Charcoal has excellent potential to reduce GHG losses caused by the land application of dairy cattle slurry. There is a need to develop biochars which are efficient in sorbing P and can improve soil quality and reduce GHG emissions. In addition, at the current cost of treatment, the increase in fertiliser value of the slurry due to some treatments is not sufficient to offset the cost of treatment. In this study, there was no significant effect of any amendment of slurry on GWP caused by land application dairy cattle slurry, with the exception of charcoal

5.7. Summary

It is critical that when evaluating the feasibility of these amendments, ‘pollution swapping’ is considered. This study has identified the need for a field study to examine the effect of the amendments on gaseous losses. In addition, there is a need to examine the effect of amendments using different soil types and wetting and drying regimes. Chapter 6 details the results of a runoff study following the landspreading of chemically amended slurry at field-plot scale and Chapter 7 examines the impact of chemically amended slurry on soil properties over a 9-mo study duration.

Chapter 6 Plot-scale rainfall simulation study

6.1. Overview

This plot-scale runoff experiment was designed to develop an understanding of the performance of amendments under more realistic conditions. In this experiment, natural drainage occurred, which did not occur in the runoff box experiments. The plot and runoff characteristics such as soil volumetric water content, time to runoff and runoff volume were also measured to investigate potential adverse effects of amendments on runoff at a larger scale.

6.2. Introduction

The present study examines the effect of chemical amendment of dairy cattle slurry with alum, PAC and lime on both P and N losses to runoff, whereas plot and runoff-box experiments which have examined chemical amendment of dairy cattle slurry to date have focused almost entirely on P losses. Although P is the limiting nutrient in freshwater systems (Correll, 1998), N losses also pose a significant risk to water quality (Johnes et al., 2007; Vitousek et al., 2009). When chemical amendments are used to reduce P losses, it is important that the effects of amendments on N losses through runoff, leaching and volatilisation are also examined to ensure that ‘pollution swapping’ does not occur.

The experimental set-up of the present study tested the efficacy and feasibility of using a variety of chemical amendments in the field, but still under controlled conditions. The objectives of this study were to investigate the effect of chemical amendment of dairy cattle slurry on: (1) average FWMC of DRP, DUP, PP and TP (2) average FWMC of

NO₃, NO₂ and NH₄-N; and (3) plot and runoff characteristics such as soil volumetric water content, time to runoff and runoff volume.

6.3. Materials and Methods

6.3.1. Study site

This study was conducted on a 0.6 ha isolated plot on a beef farm located at Teagasc, Johnstown Castle, Environmental Research Centre (latitude 52° 17'N, longitude 6° 29'W), in the southeast of Ireland (Figure 6.1). This area has a cool maritime climate, a mean annual precipitation of 1002 mm (effective rainfall from between 400 to 500 mm), and a mean annual temperature of 9.6°C (Ryan and Fanning., 1996). The location of 25 experimental plots within the 0.6 ha site was determined by: topography/slope, soil texture/drainage, depth to watertable and soil analysis. For textural analysis, 100 mm-deep soil samples (n=3) were taken from a 1 m² area at the top, middle and bottom of the plot (Figure 6.1). Soil texture was determined using PSD analysis after B.S.1377-2:1990 (BSI, 1990a). An electromagnetic conductivity and resistivity survey was also used to infer textural and drainage characteristics.

The site had undulating topography with a 6.7% slope along its length and an average slope of 3.6% across the site. The topsoil was classified as a Haplic Stagnosol (Rachel Creamer *pers com*, 2011). Combining PSD and geophysical data together, textural classes ranged from a fine loam-to-clay loam within the plot. The top of the plot comprised gravelly clay with pockets of silty/clayey gravel underlain by silt/gravel (20 to 26 mSm⁻¹) and was relatively well-drained compared to the lower part of the site, which comprised silt/clay and was poorly drained (>26 mS m⁻¹). The median perched watertable depth in three piezometers (top, middle and bottom) was 0.6 m below ground level (bgl) on site. The nutrient status of the soil at these locations was determined using Morgan's P extractant (Morgan, 1941) and, together with K and Mg, are presented in Table 6.1. The soil was classified as P index 3 (>5.1 mg L⁻¹ for grassland soils in accordance with SI 610 of 2010) throughout the site, meaning that it represented minimum risk of P loss to water.

Soil pH (n=3) was determined using a pH probe and a 2:1 ratio of deionised water to soil (Table 6.1).

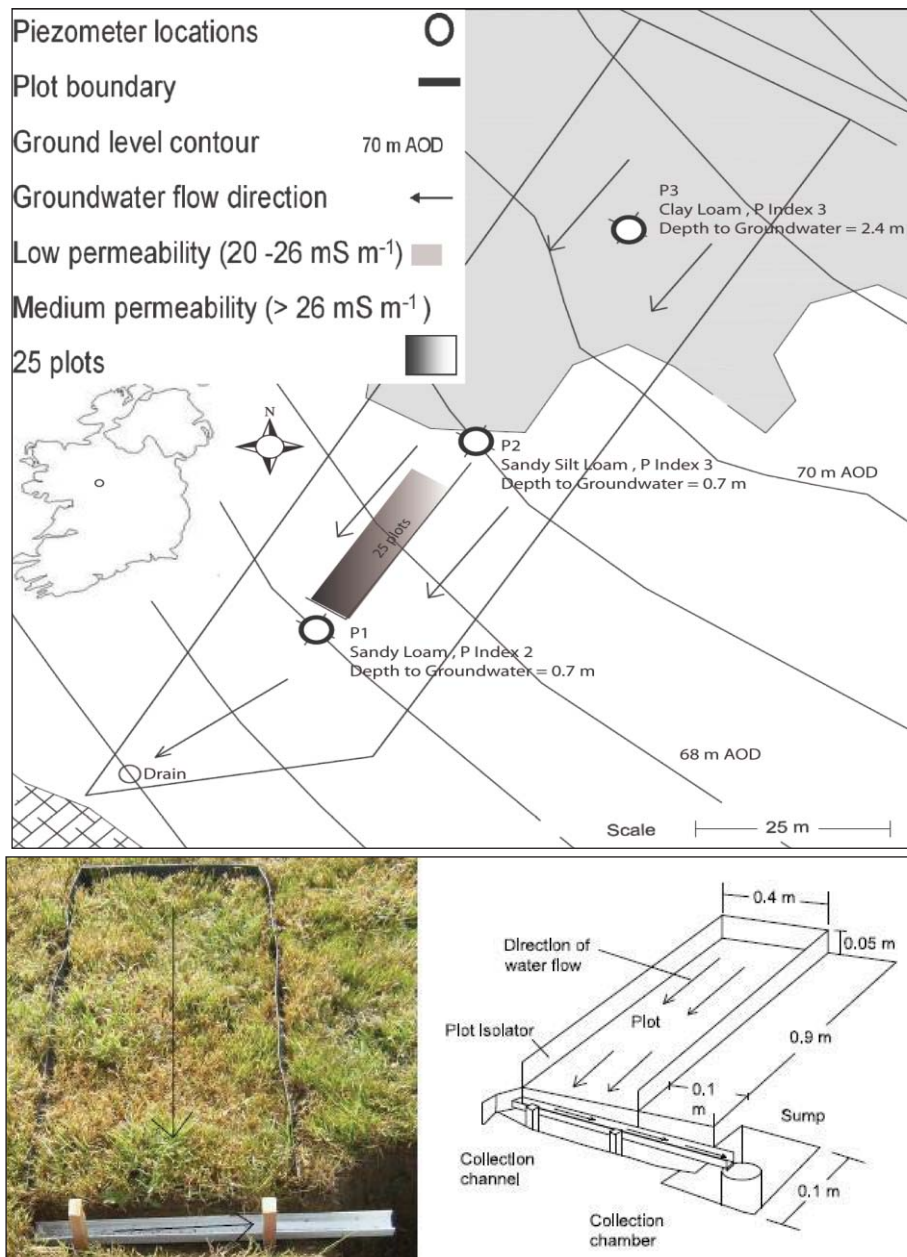

Figure 6.1 Map of study site showing ground elevation, topography, slope, soil conductivity, groundwater flow direction, location of subplots and of groundwater wells.

The location selected was of uniform topography, soil classification, texture and drainage characteristics. In addition, it was in the location of the site with the highest water table

and had relatively constant soil nutrient status. Once the study location was selected, each plot was isolated and instrumented with a runoff collection channel (Figure 6.1).

Table 6.1 Soil pH, Morgan’s extractable P, K and Mg, sand silt, clay fractions, and textural class of soil used in this study. The location of the piezometers is illustrated in Figure 6.1

Position	Piezometer No.	pH	Morgan’s P mg L ⁻¹	P index ^a	K mg L ⁻¹	Mg mg L ⁻¹	Sand %	Silt %	Clay %	Textural Class
Lower	1	5.8	2.6	2	173	171	52	30	18	Sandy Loam
Middle	2	5.9	3.2	3	140	195	47	36	18	Sandy Silt Loam
Upper	3	6.1	3.6	3	96	151	44	36	21	Clay Loam
Average		5.9	3.1		136	172	47.7	34.0	19.0	
Std dev		0.2	0.5		38.6	22	4	3.5	1.7	

^aP index is the classification system used in Ireland to classify soil P status of soils (Schulte et al, 2010b)

The treatments were randomly assigned to twenty-five plots (0.9 m by 0.4 m) which were orientated along a line. Composite soil samples (100 mm) were taken from each plot and WEP was determined (n=3). Soil pH and Morgan’s P were determined, and the slope of each plot was surveyed. Soil pH (5.96±0.22) was consistent across the 25 plots (Table 6.2). Soil test P (4.95±1.75 mg P L⁻¹) and WEP (7.24±4.52 mg P kg⁻¹) appeared to vary across the site, with lower values observed close to the location of the piezometers. Figure 6.2 shows photographs of site setup, plot installation and runoff collection troughs.

6.3.2. Slurry analysis

Cattle slurry was taken from the dairy farm at the Teagasc, Environmental Research Centre, Johnstown Castle, in August of 2010. The storage tanks were agitated and slurry samples were transported to the laboratory in 25-L drums. Slurry samples were stored at 4°C prior to land application. Slurry pH was determined using a pH probe (WTW, Germany). The TP of the dairy cattle slurry was determined after Byrne (1979). Total potassium, TN and TP were carried out colorimetrically using an automatic flow-through unit (Varian Spectra 400 Atomic Absorption instrument). The WEP of slurry and amended slurry was measured at the time of land application after Kleinman et al. (2007), and NH₄-N of slurry and amended slurry was extracted by shaking 50 g of slurry in 1 L

of 0.1 M HCl on a peripheral shaker for 1 h and filtering through No. 2 Whatman filter paper at the time of application. The results of the slurry analysis are shown in Table 6.3. The slurry sample was typical of slurry found on farms in Ireland (SI 610 of 2010). The slurry TN, TP, NH₄-N and TK were constant with the exception of the lime-treated slurry, which had high TN, TP and TK. The WEP of slurry was lowered significantly by all alum and PAC amendments. Alum addition reduced the slurry pH from approximately 7.1 to 6.5, while lime addition increased the slurry pH to 8.8.

Table 6.2 The average slope for each block, soil pH, water extractable phosphorus (WEP), Morgan’s extractable P, potassium (K), and magnesium (Mg) before application of treatments.

Block	Slope %	pH	WEP g kg ⁻¹	P mg L ⁻¹	K mg L ⁻¹	Mg mg L ⁻¹
1	4.7 (1.5)	6.1 (0.22)	5.5 (2.3)	3.25 (0.82)	49.6 (5.7)	123 (4.5)
2	3.2 (1.8)	5.9 (0.14)	7.5 (3.3)	4.9 (1.9)	55.2 (8.2)	150 (5.7)
3	2.3 (1.9)	6.06 (0.26)	11.4 (5.9)	6.9 (0.83)	59.5 (7.8)	184 (6.7)
4	3.3 (1.7)	6.02 (0.22)	6.8 (5.1)	6.07 (0.85)	58.4 (6.57)	230 (1.2)
5	4.4 (1.1)	5.77 (0.16)	5 (3.6)	3.59 (0.72)	60.8 (4.5)	218 (5.7)
Average	3.58	5.97	7.24	4.94	56.7	181
Std deviation	0.97	0.13	2.53	1.6	4.5	45

(Standard deviations in brackets)

Table 6.3 Slurry DM, pH, water extractable phosphorus (WEP), total nitrogen (TN), total phosphorus (TP) and total potassium (TK) and average concentrations of NH₄- N (n=5)

Treatment	DM	pH	WEP g kg ⁻¹	TN mg L ⁻¹	TP mg L ⁻¹	TK mg L ⁻¹	NH ₄ ⁺ -N mg L ⁻¹
Slurry	9.1 (0.54)	7.1 (0.62)	3.19 (0.37)	3960 (741)	1240 (145)	5170 (870)	1200 (260)
Alum	9.6 (0.58)	6.5 (0.44)	0.0028 (0.001)	4410 (590)	1260 (190)	5210 (640)	1160 (270)
PAC	9.42 (0.64)	6.9 (0.47)	0.0074 (0.008)	3980 (1280)	1200 (270)	4330 (1290)	1180 (290)
Lime	9.4 (0.38)	8.8 (0.67)	2.48 (0.99)	5010 (725)	1390 (150)	5610 (840)	1210 (300)
Average	9.38	7.325	1.4	4340	1270	5080	1190
Std dev	0.2	1.01	1.7	492	82.2	538	22.2

(Standard deviations in brackets)



Grass cut and plots isolated



Plot during micro-plot installation



Plot isolation



Runoff collection. Shield removed to allow photo to be taken

Figure 6.2 Plot set up and runoff collection photograph

6.3.3. Treatments

The five treatments examined in this study were: (1) grassed soil-only, (2) slurry-control (3) industrial grade liquid alum ($\text{Al}_2(\text{SO}_4)_3 \cdot n\text{H}_2\text{O}$), comprising 8% Al_2O_3 (4) industrial grade liquid poly-aluminium chloride hydroxide (PAC) ($\text{Al}_n(\text{OH})_m\text{Cl}_{3n-m}$) comprising 10% Al_2O_3 and (5) lime ($\text{Ca}(\text{OH})_2$). Amendments were added to the slurry and mixed rapidly by shaking in 2-L containers immediately prior to land application. Two days

before the first rainfall simulation, slurry and amended slurry were applied directly to the surface of the grassed soil. Slurry application rates were equivalent to 33 m³ slurry ha⁻¹ (42 kg TP ha⁻¹), the rate most commonly used in Ireland (Coulter and Lalor, 2008). Amendments were applied at stoichiometric ratios determined in Chapter 3. Alum was applied at a rate of 1:1 (Al: TP); poly-aluminium chloride at a rate of 0.85:1 (Al: TP); and lime at a rate of 3.9:1 (Ca: TP). Appendix E shows photographs of amended slurry.

6.3.4. Rainfall simulation

Two identical portable multi-drop ‘Amsterdam type’ rainfall simulators, described by Bowyer-Bower and Burt (1989), were used in this study. These rainfall simulators have been used on similar permanent grassland sites and soil types (Kurz et al, 2006; Kramers et al., 2009; O’Rourke et al, 2010). The rainfall simulators were designed to distribute rainfall over a surface area of 0.5 m² and were calibrated to deliver rainfall at an intensity of 11 mm h⁻¹. In order to ensure the absence of edge effects, the study plots – each measuring 0.36 m² in area - were positioned directly under the rainfall simulator. The plots were isolated using 2.2 m-long, 100 mm-deep rigid plastic sheets, which were pushed 50 mm into the soil to isolate three sides of the plot. The runoff collection channel was placed at the bottom of the slope (Figure 6.1). Plots were orientated with longest dimension in the direction of the slope (average 3.6 %). The runoff collector comprised a polypropylene plastic U-shaped channel piece, which was cut in half and wedged against the soil at a depth of approximately 25 mm below the soil surface (Figure 6.1).

A 400 mm-wide edging tool was used to ensure a good seal between soil and collector. The plots were left uncovered for two weeks prior to first rainfall simulation to allow natural rainfall to wash away soil disturbed by inserting the isolators. The grass on all plots was clipped to a height of 50 mm two days prior to the first simulated rainfall event. Figure 6.3 shows one of the rainfall simulators used in this study. Land application of treatments was staggered over three days and applied in blocks to allow for the first rainfall event (RS1) two days after land application of slurry. The second event (RS2) was 10 d after the original application (t = 12 d) and the third (RS3) after 28 d (t = 30 d).

Rainfall simulations were carried out between 17th September 2010 and 18th October 2010 (Figure 6.4).



Wind shield used to prevent rain from blowing rain



View of rainfall simulator before rainfall starts

Figure 6.3 Photographs of rainfall simulator

The allocation of the rainfall simulators was randomised between blocks and alternated for treatments. Runoff was judged to occur once 50 ml of water was collected from the runoff collection channel and the time from start of rainfall simulation to runoff of 50 ml being the time to runoff (TR). Samples were collected every 5 min for RS1, and every 10 min for RS2 and RS3. Surface runoff was collected for 30 min once runoff commenced to allow the FWMC to be calculated (Kurz et al., 2006). Rainfall simulator input water had the following average concentrations: 0.05 mg $\text{NH}_4\text{-N L}^{-1}$, 4.61 mg $\text{NO}_3\text{-N L}^{-1}$, 0.001 mg DRP L^{-1} and 0.004 mg TP L^{-1} ; 0.00 mg $\text{NH}_4\text{-N L}^{-1}$, 4.53 mg $\text{NO}_3\text{-N L}^{-1}$, 0.004 mg DRP L^{-1} and 0.00 mg TP L^{-1} ; 0.00 mg $\text{NH}_4\text{-N L}^{-1}$, 4.51 mg $\text{NO}_3\text{-N L}^{-1}$, 0.00 mg DRP L^{-1} and 0.00 mg TP L^{-1} for RS1, RS2 and RS3 respectively.

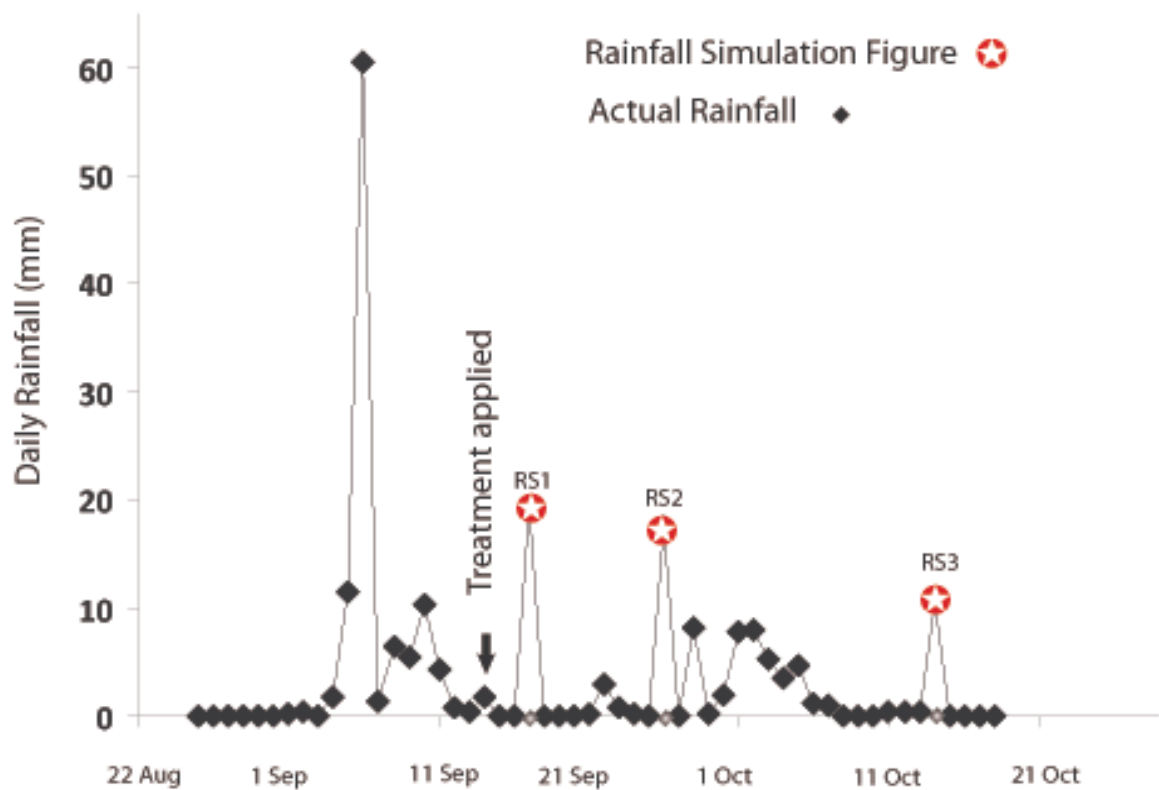

Figure 6.4 Natural rainfall and average depth of simulated rainfall received by the plots for each event

The volumetric water content of soil in each plot was measured immediately prior to each rainfall simulation event using time domain reflectometry (Delta-T Devices Ltd., Cambridge, UK) (Figure 6.5), which was calibrated to measure resistivity in upper the 50 mm of the soil in each plot. Three readings were taken in each plot and the average was calculated.



Figure 6.5 Photo of the measurement of volumetric water content of soil using time domain reflectometry

Immediately after collection, runoff water samples were filtered through 0.45 μ m filter paper and a subsample was analysed colorimetrically for DRP, total oxidized nitrogen (TON), NO₂-N and NH₄-N using a nutrient analyser (Konelab 20, Thermo Clinical Labsystems, Finland). Nitrate was calculated by subtracting NO₂-N from TON. A second filtered sample was analysed for TDP using acid persulphate digestion. Unfiltered runoff water samples were analysed for TP with an acid persulphate digestion. Particulate phosphorus was calculated by subtracting TDP from TP. The DRP was subtracted from the TDP to give the DUP. All samples were tested in accordance with the Standard Methods (APHA, 1995).

6.3.5. Statistical analysis

The structure of the data (Appendix F) set was a blocked one-way classification (treatments) with repeated measures over time (events). The analysis was conducted using Proc Mixed in SAS software (SAS, 2004) with the inclusion of a covariance model to estimate the correlation between events. A large number of covariates were recorded, including measurements on the simulators. For each analysis, this set of covariates was screened for any effects that should be included in an analysis of covariance. The

interpretation was conducted as a treatment x time factorial. Comparisons between means were made with compensation for multiple testing effects using the Tukey adjustment to p-values. Significant interactions were interpreted using simple effects before making mean comparisons. In order to ensure that STP variation did not affect the experiment, STP was included as a variable in the statistical analysis. Slurry concentration, which was of much greater significance in terms of P concentrations in runoff following slurry application, was uniform within each block.

6.4. Results

6.4.1. Phosphorus (FWMC of DRP, DUP, PP and TP)

The average FWMC of DRP, DUP and PP, which comprise TP in runoff, are shown in Figure 6.6. During RS1, alum ($p<0.05$) and PAC ($p<0.001$) reduced DRP in runoff water compared to the slurry-control by 95 (0.13 mg P L⁻¹) and 98% (0.05 mg P L⁻¹), respectively. Alum and PAC, at $p<0.02$ and $p<0.01$, also reduced TP concentrations in runoff from the plots during RS1 by 92 (0.61 mg P L⁻¹) and 83% (1.37 mg P L⁻¹), respectively, compared to the slurry-control. None of the amendments examined reduced FWMC of DRP or TP losses to below the MAC during the study.

The FWMC of TP and DRP for the alum-amended plots did not show any discernable trend, although the average reduction in FWMC, compared to the slurry-control, over the three rainfall events, for TP and DRP was 81 and 77%, respectively. Comparatively, the FWMC of TP continued to reduce over the three rainfall events for the PAC-amended plots, although the DRP concentrations were still over the MAC for all runoff events. Alum-treated slurry and PAC-treated slurry were not significantly different to each other throughout the study. However, there was a significant difference in FWMC of TP in runoff during RS1 between soil-only ($p<0.05$), alum ($p<0.05$) and PAC ($p<0.01$) compared to the slurry-control.

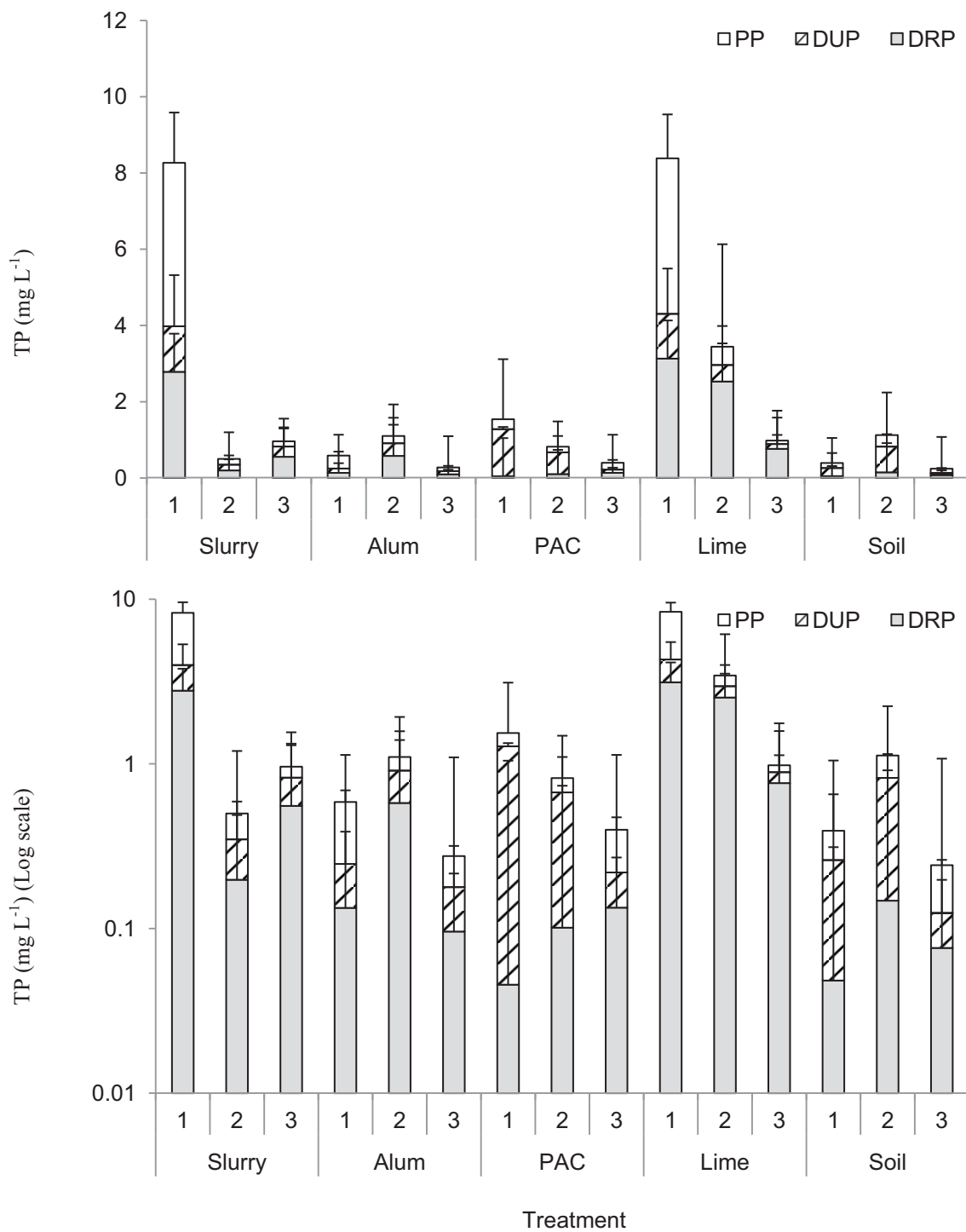

Figure 6.6 Average flow-weighted mean concentrations of dissolved reactive phosphorus (DRP), dissolved un-reactive P (DUP) and particulate P (PP) comprising total P (TP) for three rainfall simulation events, and maximum allowable concentrations (MAC) in waterways.

The addition of lime increased the average FWMC of DRP and TP over the three rainfall events, compared to the slurry-control, by 82 and 38%, respectively. This increase in P loss as a result of lime amendment may be due to the pH of the lime-amended slurry. Penn et al (2011) found that in order for Ca-phosphate bonds to remain stable, the pH must remain in a range of 6.5 to 7.5. The average pH of the soil on the site was 5.97 and the pH of the lime-amended slurry was 8.8 at the time of application. Chapter 3 showed that the pH of lime-amended dairy cattle slurry increased in the first 24 h following land application. The slurry pH was too high for Ca-P bonds to be stable during RS1 and when the slurry and soil interacted and reached equilibrium, the soil pH was lower than the optimal pH for the formation of Ca-P bonds. This may be why reductions were not observed during RS2 and RS3.

6.4.2. Nitrogen

The average FWMC of $\text{NO}_3\text{-N}$, $\text{NO}_2\text{-N}$ and $\text{NH}_4\text{-N}$ in runoff water for grassed soil-only plots for the three simulated rainfall events were $3.98 \text{ mg NO}_3\text{-N L}^{-1}$, $0.03 \text{ mg NO}_2\text{-N L}^{-1}$ and $0.22 \text{ mg NH}_4\text{-N L}^{-1}$ compared to $3.6 \text{ mg NO}_3\text{-N L}^{-1}$, $0.02 \text{ mg NO}_2\text{-N L}^{-1}$ and $0.82 \text{ mg NH}_4\text{-N L}^{-1}$ for the slurry-control (Figure 6.7). The $\text{NO}_3\text{-N}$ and $\text{NO}_2\text{-N}$ concentrations in runoff water from soil only plots were not in excess of the MAC of $11.3 \text{ mg NO}_3\text{-N L}^{-1}$ (EEC, 1988) and $0.1 \text{ mg NO}_2\text{-N L}^{-1}$ (OJEC, 2006) for salmonidal rivers. The addition of amendments had no significant effect on NO_3 concentration in runoff water. Ammonium concentrations in runoff from plots receiving alum-amended dairy cattle slurry, averaged across the rainfall events, were in excess of lower drinking water standards of $0.2 \text{ mg NH}_4\text{-N L}^{-1}$, but below the upper limit of $4 \text{ mg NH}_4\text{-N L}^{-1}$ (EEC, 1989).

The alum amendment increased $\text{NH}_4\text{-N}$ in runoff by 84% from $2.4 \text{ mg NH}_4\text{-N L}^{-1}$ in the slurry-control to $4.3 \text{ mg NH}_4\text{-N L}^{-1}$ during RS1, while PAC reduced $\text{NH}_4\text{-N}$ in runoff by 80% ($0.4 \text{ mg NH}_4\text{-N L}^{-1}$) compared to slurry-control during RS1. Lime had no significant effect on $\text{NH}_4\text{-N}$ concentrations in runoff water. The peak in NH_4 loss during RS1 was a result of the application of dairy cattle slurry, which was high in NH_4 .

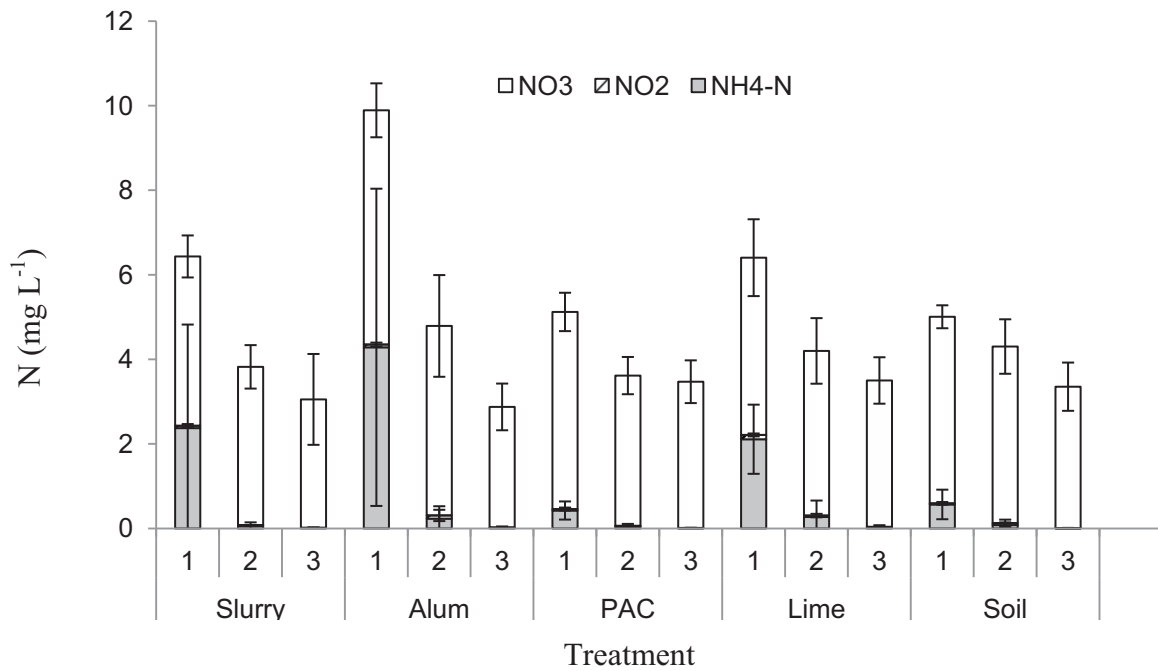

Figure 6.7 Average flow-weighted mean concentrations of ammonium nitrate (NH₄-N), nitrite (NO₂-N) and nitrate (NO₃-N) for three rainfall simulation events, and maximum allowable concentrations (MAC) in waterways.

6.4.3. Time to runoff, soil volumetric water content and runoff volume

The rainfall intensity, volume of runoff (converted to equivalent depth), time from start of rainfall application to start of runoff event, and volumetric water content of the soil at the start of each rainfall simulation are shown in Figure 6.8. Almost 90% of all rainfall applied drained away or leached through the soil, with 7.8% of water applied to soil-only being collected as runoff from the upper 25 mm of the soil surface, 9% for the slurry-control, 9.4% for alum-amended slurry, 15% for PAC-amended slurry and 14.3% for lime-amended slurry. The runoff volumes were not statistically different to each other.

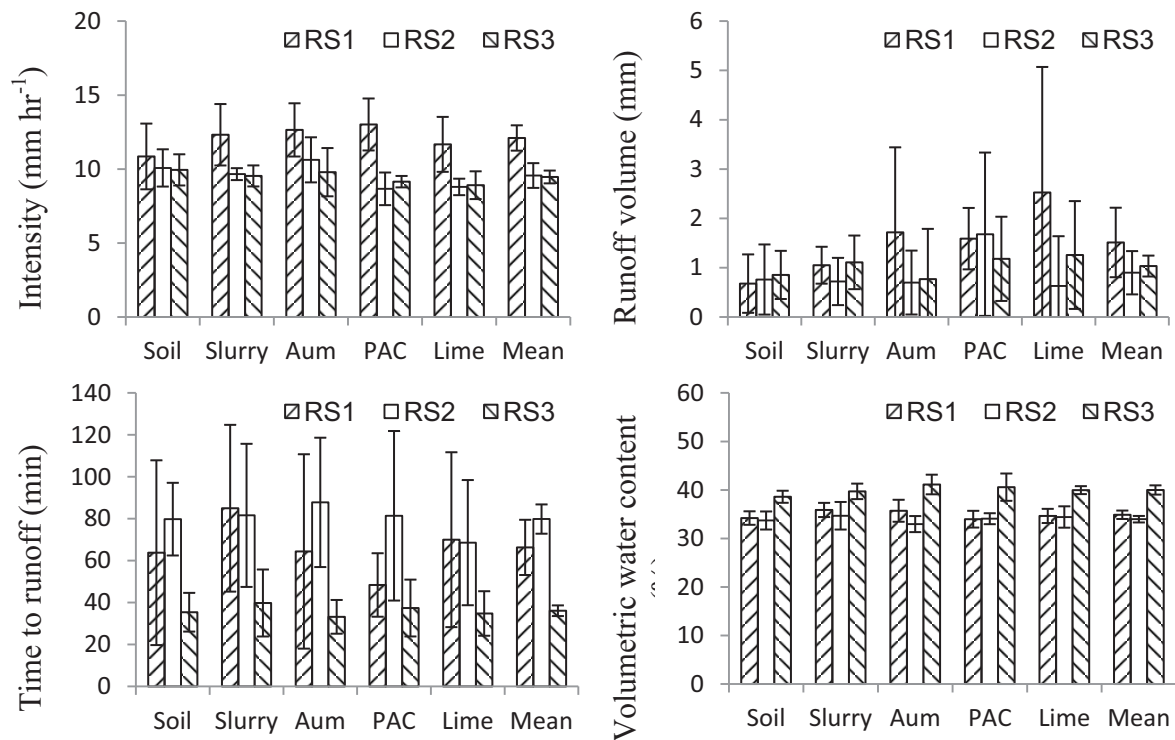

Figure 6.8 Average rainfall intensity, runoff volume, time to runoff and soil volumetric water content for the first (RS1), second (RS2) and third (RS3) rainfall events.

There was no statistical evidence of any effect of rainfall simulator on the experimental outcome. The average intensity for each rainfall simulation event for the two simulators was 10 ± 1.8 mm h⁻¹ and 10.7 ± 1.93 mm h⁻¹, respectively. Rainfall intensity and soil water content did not have a significant effect on TR, runoff volume, or P and N losses. Covariate analysis of the logarithmic of the TR showed that event ($p < 0.001$) and slope ($p < 0.01$) of plots affected TR.

6.5. Discussion

6.5.1. Phosphorus (FWMC of DRP, DUP, PP and TP)

Throughout the study, the DRP concentrations in runoff water from soil-only plots were in excess of the MAC of 0.03 mg DRP L⁻¹ for surface waterbodies in Ireland (Flanagan, 1990). The average FWMC of TP for the soil only treatment was in excess of water quality limit of 0.025-0.1 mg TP L⁻¹ (USEPA, 1986) for surface water in the USA. The concentrations in runoff from the slurry-control plots were also all in excess of the MAC for DRP and TP for the duration of the study. However, the buffering capacity of water means that the concentration of the water in a surface waterbody will not be as high as the concentration of runoff, provided runoff from slurry flows over soil which has not received dairy cattle slurry (McDowell and Sharpley, 2002b).

The results of the present study show that chemical amendments can be used to reduce P solubility in dairy cattle slurry and thus reduce P loss to a surface waterbody. Alum and PAC reduced P losses significantly compared to the slurry-control. Possible reasons for this failure to achieve runoff concentrations below the MAC may be insufficient chemical amendment of slurry, rainfall intensity and insufficient contact time to achieve adsorption of P. Incidental P losses accounted for the majority of P losses from the slurry-control plot during the study, with approximately 75% of DRP, 72% of DUP, 94% of PP and 83% of TP losses, measured over the three rainfall events, occurring during RS1. While incidental losses were significantly reduced in the alum and PAC-amended plots, the effect of amendments on chronic loss of P from the plots was not clear as differences in runoff concentrations during RS3 and were not statistically significantly to slurry control.

The results show that even in low P Index soils, there is risk of DRP concentrations, which are in excess of the MAC in runoff, entering drains. In a similar plot study with simulated rainfall applied at 25 mm h⁻¹, Kruz et al. (2006) observed an average FWMC of DRP of 0.99 mg L⁻¹ from soil with a Morgan's P varying between 5 mg P L⁻¹ and 7 mg P L⁻¹. These concentrations are all similar to the soil only treatment in this study.

The results in this study were similar to previous work (Preedy et al., 2001; Kleinman and Sharpley, 2003; Hanrahan et al., 2009). Kleinman and Sharpley (2003) applied dairy cattle slurry to grassed runoff boxes at 50 kg TP ha⁻¹. Runoff boxes were subjected to simulated rainfall at 70 mm h⁻¹ three days after application, and DRP in runoff was 3.2 mg DRP L⁻¹. We have therefore shown that even when slurry was applied within guideline application rates, concentrations of P in runoff were still in excess of limits. In practice, runoff from fields receiving slurry will pass through a buffer area and undergo dilution before it enters a waterway. This means that the concentrations measured in this paper were higher than the actual concentration of the water that would enter the waterway if these treatments were used in practice. Timing of slurry application and incorporation of slurry may be a much more feasible way to reduce incidental P losses.

6.5.2. Nitrogen

On a low permeability soil, infiltration of N is unlikely and at this location N will predominantly be lost in runoff to rivers. Dairy cattle slurry is high in NH₄-N, which may explain the high NH₄-N in runoff during RS1. The reduction in NH₄ concentrations in runoff between RS1 and RS2 across all treatments, including the slurry-control, was likely due to nitrification occurring in the soil following slurry application, and interaction with the soil. Nitrification occurs when microbes use enzymes to convert NH₄ to NO₂ and then NO₃ to obtain energy (Ketterings et al., 2011). This also explains why there was so little NO₂ in the runoff water in comparison to NO₃.

Land application of dairy cattle slurry resulted in an increase in NH₄-N compared to soil only. Smith et al. (2001b) reported similar findings. Smith et al. (2001b) added dairy cattle slurry at a rate 75 m³ ha⁻¹ to grassed plots and reported soluble N (NH₄-N+NO₃-N) concentrations ranging from 2 mg L⁻¹ to 14 mg L⁻¹, which was comparable to the average FWMC of soluble N observed in this study (6.3 mg L⁻¹). Nitrite losses were not significant and were equivalent to approximately 1.9% of NO₃ for most samples. Land application of dairy cattle slurry did not have a significant effect on NO₃ loss to runoff water; this was in agreement with results from Smith et al. (2001b). Alum increased NH₄-

N loss during first rainfall event, while PAC reduced $\text{NH}_4\text{-N}$ loss compared to the slurry-control. These results indicate that chemical amendments could potentially increase N in runoff from dairy cattle slurry.

It is critical that the potential for ‘pollution swapping’ is examined when evaluating chemical amendment of dairy cattle slurry. In particular, the effects of any amendments on GHG emissions must be examined. Under the 1997 Kyoto Protocol of the United Nations Framework Convention on Climate Change (UN, 1998), participating nations agreed to publish national inventories of anthropogenic emissions of several GHG and to reduce future emissions below 1990 levels. In Ireland, agricultural activities were responsible for approximately 26% of total GHG emissions in 2008 (McGettigan et al., 2010) and account for virtually all NH_3 emissions, with animal manure alone responsible for 92% of NH_3 emissions (EPA, 2010). While NH_3 is not a GHG, it contributes to acidification of soils, atmospheric pollution, and the eutrophication of surface and ground water systems (Goulding et al., 1998). An estimated 5% of global N_2O emissions results from the conversion of NH_3 into N_2O in the atmosphere (Ferm, 1998). In addition to gaseous N losses (Amon et al., 2006), agricultural activities, such as land application of dairy cattle slurry, contribute to the production of NH_3 and GHG, such as CO_2 , N_2O (Ellis et al., 1998) and CH_4 (Chadwick et al., 2000). Therefore, any chemical amendments which alter slurry properties may have an effect on GHG emissions.

6.5.3. Rainfall intensity, soil volumetric water content, time to runoff and runoff volume

Land spreading of dairy cattle slurry at high rates may result in sealing of the soil surface by slurry solids. Smith et al. (2001b) reported a 16% increase in runoff volume compared to soil-only control when dairy cattle slurry was applied to the soil surface at $40 \text{ m}^3 \text{ ha}^{-1}$. This is similar to an 11.5% increase in runoff volume observed in the present study, this increase was not, however, statistically significant. Chemical amendments of slurry appeared to increase runoff volume compared to the slurry-control, but the differences in runoff volume were not statistically significant. The rainfall simulation event was found

to have the greatest impact on runoff volume ($p < 0.05$). There was a difference between plots, but the differences were not statistically significant.

There was no statistically significant effect of treatment on runoff or TR. This indicated that the effect of amendment on any surface sealing which may have occurred was minimal. However, the lack of a relationship between soil water content and runoff properties may be a result of scale effects. The soil around the plots received no rainfall; this may also have resulted in an artificially high TR. In a similar plot study, Kleinman et al. (2006) examined the role of rainfall intensity and hydrology in nutrient transport *via* surface runoff and observed that despite significant differences in runoff generation processes (volume of runoff and TR), the concentrations of DRP in runoff were related to the STP of the grassed soil. Similar results were observed in the present study, however the DRP concentrations were dependent on the WEP of the slurry applied and not STP of the soil.

Although amendments increased runoff at plot-scale, the effect of such an increase at field-scale cannot be fully known. There is potential that if runoff increased at a larger scale, increased erosion and loss of PP could occur. The variation observed in runoff has significant implications for comparing the results of this work with field-scale studies. Potential scale effects which must be considered include: (1) dilution due to different runoff volumes and TR (2) differing soil texture/permeability in between plots and (3) length of collection period, as the FWMC of the various measured water quality parameters may be artificially high since the water samples were not collected after rainfall stopped.

6.5.4. Outlook for future implementation of chemical amendment of dairy cattle slurry as a management practice for high P soils

This study demonstrated that PAC was the most effective chemical amendment to reduce incidental DRP losses from dairy cattle slurry, with alum being most effective at reducing DUP and TP losses. Alum and PAC significantly reduced P losses, particularly in RS1,

while lime resulted in increased P losses and is not a suitable amendment at the rates examined in this study.

The estimated cost of chemical amendment, calculated in Chapter 3, and based on the estimated cost of chemical, chemical delivery to farm, addition of chemical to slurry, increases in slurry agitation, and slurry spreading costs as a result of increased volume of slurry, increases the cost of land application from approximately €1.90 m⁻³ for slurry only to €6.5 m⁻³ for alum-, €7.60 m⁻³ for PAC-, and 4.90 m⁻³ for lime-amended slurry. The TP lost from slurry-control plots during the study period had an approximate P fertiliser value of €5.48 ha⁻¹ compared to €0.82 ha⁻¹ lost from grass-only. Alum and PAC reduced the value of P lost to €1.45 ha⁻¹ and €2.50 ha⁻¹, respectively, while lime increased the value of TP lost to €14.7 ha⁻¹. The value of TP applied to plots receiving dairy cattle slurry and un-amended slurry was €82.7 ha⁻¹.

Chemical amendment could be used in strategic areas (e.g. on farms with surplus P) to reduce P solubility in manure and P transfer to a surface and ground waters, whilst allowing farmers to utilise other nutrients in slurry on farms with high STP. In certain U.S states (Arkansas, Alabama, Tennessee and South Carolina), alum amendment of poultry litter is used as a standard conservation practice (Moore and Edwards, 2005). At present, there is no provision for a licence to landspread any of these amendments in Europe and if chemical amendment were to be used, a licensing system would have to be introduced by the relevant bodies. The plant availability of P in chemically amended manure is a major concern for stakeholders. Moore and Edwards (2005) has shown that chemical amendment improves yields due to increased N efficiency. In addition, in this study, chemical amendment is proposed for use to reduce P solubility where farmers have a short-term P surplus, and is recommended for strategic use within a catchment. Therefore, it should not be used in a site with low STP. Further work is required to assess the long-term availability of P bound in Al bonds and if STP would decline as a result of chemical amendment of dairy cattle slurry prior to land spreading.

6.6. Conclusions

The results of this plot-scale study validated results from micro-scale and meso-scale studies conducted in the laboratory. Treatment was not found to have a significant effect on time to runoff or volume of runoff. When compared to the slurry-control, alum and PAC reduced DRP by 95 and 98%, respectively, in runoff following RS1. Alum and PAC also reduced TP losses during RS1 by 85 and 92%, respectively. Lime increased P losses compared to the slurry-control. Addition of amendments had no significant effect on $\text{NO}_3\text{-N}$ in runoff water. Alum and lime increased the FWMC of $\text{NO}_2\text{-N}$ in runoff by 120 and 114% compared to the slurry-control. Alum amendment increased $\text{NH}_4\text{-N}$ in runoff by 84% compared to the slurry-control, while PAC reduced $\text{NH}_4\text{-N}$ in runoff by 80% compared to the slurry-control. Lime had no effect on $\text{NH}_4\text{-N}$ concentrations in runoff water. Alum amendment significantly increased average FWMC of $\text{NH}_4\text{-N}$ in runoff water during the first rainfall event after slurry was applied. This indicates that amendment on a large scale could increase soluble N losses and that large scale disposal to land may pose a problem.

6.7. Summary

At the scale of the present study, alum and PAC provide the best value in reducing the TP loss from slurry; however, they are still very expensive. The next step is to examine the effects of long-term use of these amendments at field-scale and to quantify their effect on plant availability of P and GHG emissions. In addition, there is a need for a much greater examination of pollution swapping of N, with a focus on transfer of N to groundwater via leaching. Chapter 7 will examine the impact of chemically-amended slurry on soil WEP, plant available P and soil pH over a study with duration of 9 months.

Chapter 7 The long-term impact of the addition of chemically amended dairy slurry on phosphorus content and pH of five soil types

7.1. Overview

In this chapter, the impact of chemically amended dairy slurry application to land on soil WEP, plant available P and soil pH was examined across 5 different soil types in Ireland.

7.2. Introduction

A number of studies have examined the effect of chemical amendments on reducing P solubility in slurry (Dao, 1999), reducing P solubility in soil and slurry mixtures (Dao and Daniel, 2002), and reducing P in runoff from soils receiving amended slurry (Chapter 4). With the exception of Kalbasi and Karthikeyan (2004), there has been little research on the effect of chemical amendments on long-term P dynamics in soil following application of chemically amended dairy cattle slurry. Kalbasi and Karthikeyan (2004) examined three silt loam soils with different STPs in an incubation experiment conducted over a 24-mo period. Kalbasi and Karthikeyan (2004) amended the soils with either untreated dairy manure, alum-treated dairy manure, ferric chloride-treated dairy manure, or lime-treated dairy manure. Results showed the effect of chemical amendment depended on treatment type, P application rate and background STP. Kalbasi and Karthikeyan (2004) concluded that more work was needed to investigate the effects of soils varying in physical and chemical characteristics.

7.3. Materials and methods

7.3.1. Soil collection and analysis

Soils were selected from the upper 100 mm of 5 sites to represent some common soil types used in dairy farming in Ireland (Figure 7.1). The 5 soils collected were in the optimum range (5.1-8 mg L⁻¹) of STP for productive grasslands with the exception of soil from Site C (Table 7.1), which was P deficient, and the peaty soil (soil E), which had a high STP. The peat soil was included as there is a particular risk of P loss from peat soils as they have poor capacity to store P (Cummins and Farrell, 2003) and could represent a critical source if P was applied in excess of agronomic requirements of crops. Fay et al. (2007) reported that 50% of mineral and organic soils had respective STPs lower than 6.4 mg L⁻¹ and 9.3 mg L⁻¹ in the upper 100 mm. Soils with different texture, OM, and pH were selected to test the effectiveness of the amendments in a variety of conditions. The selected soils give an indication of the stability of metal-phosphate bonds formed as a result of chemical amendment in a wide variety of conditions.

Laboratory analysis was conducted to characterise the soil used in this study. The soil was air dried and crushed to pass a 2 mm sieve. Sub-samples were taken, dried at 40 °C for 72 h, and analysed for Morgan's P using Morgan's extracting solution (Morgan, 1941). Soil WEP (100:1 deionised water: soil) was determined after McDowell and Sharpley (2001). Soil pH (n=3) was determined using a pH probe and a 2:1 ratio of deionised water-to-soil. Particle size distribution was determined using B.S.1377-2:1990 (BSI, 1990a) and OM of the soil was determined using the LOI test (B.S.1377-3; BSI, 1990b). The results are presented in Table 7.1. Soil pH (n=3) was determined using a pH probe and a 2:1 ratio of deionised water-to-soil.

7.3.2. Slurry collection and analysis

Dairy cattle slurry from dairy replacement heifers was taken from a farm (53°18' N, 8°47' W) in County Galway, Republic of Ireland, in Summer (June), 2010. The storage

tanks were agitated and slurry samples were transported to the laboratory in 10-L drums. Slurry samples were stored at 4°C prior to testing. Slurry pH was determined using a pH probe (WTW, Germany). The TP of the dairy cattle slurry was determined after Byrne (1979). Total potassium was analyzed using a Varian Spectra 400 Atomic Absorption instrument, and analyses for TN and TP were carried out colorimetrically using an automatic flow-through unit. The slurry application used in this experiment was based on an application rate of 33 m³ ha⁻¹, which is common practice in Ireland (Coulter and Lalor, 2008). In order to facilitate randomisation, the same slurry application rate was selected for all soils. Amendment application rates to reduce soluble P in slurry were based on the results of Chapter 3.

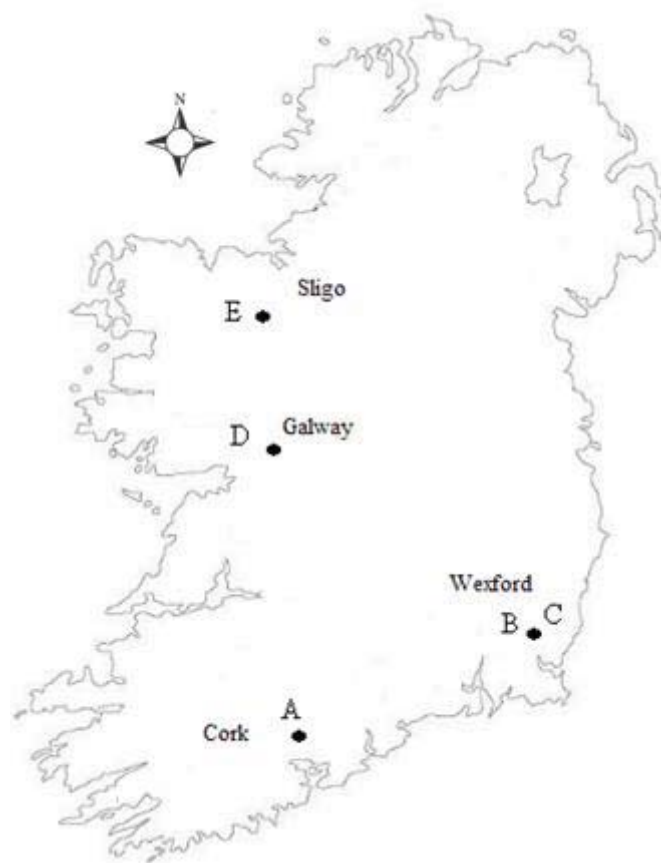

Figure 7.1 Site locations shown on map of Ireland

The slurry characterisation is shown in Table 7.2. The pH of slurry decreased for each of the acidifying amendments and increased for lime. The slurry sample was typical of slurry found on farms in Ireland (SI 610 of 2010). The slurry TN, TP, NH₄-N and TK were relatively constant with the exception of the lime-treated slurry, which had high TN, TP and TK. Alum, PAC and FeCl₃ addition reduced the slurry pH from approximately 7.2 to 5.1, 5.7 and 5.4 ($p < 0.001$), respectively, while lime addition increased slurry pH to 12 ($p < 0.001$).

7.3.3. Incubation experiment

This 9-mo incubation study comprised six treatments, conducted in triplicate ($n=3$), at a fixed temperature of 11°C on: (1) soil only (to take account of the effects of incubation) (2) soil mixed with dairy cattle slurry (the study control); and soil mixed with dairy cattle slurry, which was amended with either (3) alum (4) lime (5) PAC, or (6) FeCl₃ (In this study FeCl₃ was used instead of FeCl₂ as FeCl₃ is the most commercially available form).

First, 100 g samples of air dried soil, passed through a 2 mm sieve, were placed in 0.5-L containers. A volume of deionised water required to achieve 50% approximate field capacity was added and mixed with the soil using a spatula. Soil container capacity (CC), which is an approximate measurement of field capacity, was determined for each soil after Bond et al. (2006). To determine approximate field capacity, 100g of air-dried soil was placed in a container (with holes in the bottom) and saturated with deionised water. The container was then covered with para-film (perforated to allow air to circulate) and allowed to drain for 48 h through the drainage ports in the bottom of the container. It was then dried at 105° C and reweighed. This difference in weight was the CC (kg water kg⁻¹ soil).

Table 7.1 Soil physical and chemical properties.

Site	Soil A	Soil B	Soil C	Soil D	Soil E
Coordinates	52°07' N, 8°16' W	52°17' N, 6°31' W	52°17' N, 6°31' W	53°21' N, 8°34' W	54°04' N, 8°52' W
Location	Cork	Wexford	Wexford	Galway	Sligo
Soil texture	Sandy loam	Clay loam	Clay loam	Silty loam	Peat soil (na)
Sand content	56.2 (1.1)	51.8 (4.2)	37.8 (1.1)	15 (1.4)	-
Silt content	25.8 (1.3)	28.1 (4.9)	31.1 (1.0)	72 (1.1)	-
Clay content	18 (2.4)	20.1 (2.2)	31.1 (2.1)	13 (1.2)	-
Water extractable phosphorus	7.2 (1.2)	6.2 (2.1)	2.7 (0.9)	3.2 (1.5)	42.5 (4.5)
Organic matter content	7.9 (0.6)	7.8 (0.26)	6.7 (0.5)	13.3 (0.23)	77.4 (0.2)
Soil pH	6.1 (0.85)	5.7 (0.08)	6.5 (0.02)	5.1 (0.04)	5.6 (0.05)
Potassium	136 (5.4)	248 (2.9)	106 (1.1)	102 (6.1)	126 (6.4)
Magnesium	217 (9.1)	377 (19.4)	225 (2.1)	124 (2.9)	527 (48.7)
Lime requirement of soil	2 (0.6)	5 (0.3)	XLS	3 (0.3)	12 (0.3)
Soil test phosphorus (Morgan's)	5.8 (0.34)	5.7 (0.1)	2.6 (0.2)	5.1 (0.42)	24.6 (0.2)
P Index ^a	3	3	1	3	4
Container capacity	675 (32)	634 (12)	539 (8)	825 (43)	2110 (59)
Soil bulk density	1.29	1.15	1.08	0.93	0.27

(Standard deviations in brackets), XLS: no lime requirement; ^aP Index: soils in Ireland ranked based on risk of P loss (Index 1 being low risk and 4 being the highest);

Table 7.2 Slurry properties

Treatment	Rate metal to TP	DM %	pH	TN mg L ⁻¹	TP mg L ⁻¹	TK mg L ⁻¹
Slurry		10.45 (0.78)	7.2 (0.34)	4860 (425)	1140 (93)	3110 (254)
Alum	1.5:1 (Al:TP)	10.1 (0.35)	5.1 (0.35)	4660 (201)	1120 (19)	2840 (167)
Lime	16:1 (Ca:TP)	13.8 (0.17)	12 (0.25)	3590 (459)	944 (79)	2620 (430)
PAC	1.4:1 (Al:TP)	9.9 (0.35)	5.7 (0.4)	5320 (379)	1280 (154)	3060 (617)
FeCl ₃	1.5:1 (Fe:TP)	11.4 (0.69)	5.4 (0.1)	5020 (283)	1180 (84)	3100 (153)

(Standard deviation in brackets)

The bulk density of each soil used in this study was determined based on the volume of 100g of sieved soil occupied in a container after field capacity was achieved (Table 7.1). Following this, slurry, or amended slurry, was added and mixed thoroughly (using a spatula) before being compacted to volume which was determined based on bulk density of soil and volume of slurry applied and water added. A packer was custom made (Figure 7.2) to compress soil to the approximate height. This height was determined based on soil bulk density, volume of water added and volume of slurry added (if added).

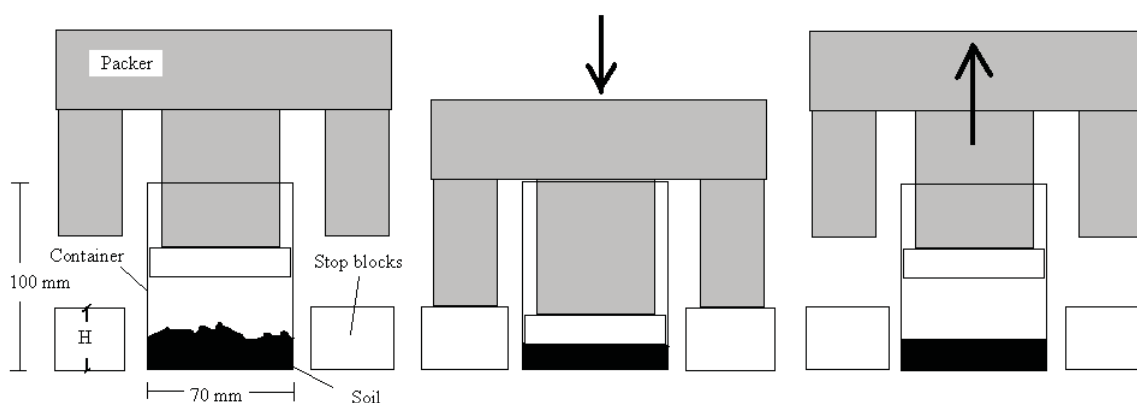

First, the soil, slurry and deionised water were mixed in the container. The height of the stop blocks required to achieve appropriate bulk density was selected and placed beside the container

The mixture was then compacted to an appropriate bulk density.

The packer was then removed and cleaned using deionised water and drying paper before being used again.

Figure 7.2 Schematic of packer used to achieve approximate bulk density

The amendments were applied at a stoichiometric rate based on the TP of the slurry (Table 7.2). The mineral soils examined have a mean bulk density of $1.12 \pm 0.15 \text{ g cm}^{-3}$ in the containers used to calculate field capacity and for the purpose of selecting slurry application rate, it was assumed that land applied slurry only interacts with the upper 20 mm of soil. Studies have shown that the STP in the upper 20 mm of grassland soils tends to be higher than for the equivalent depth in tillage soils receiving the same manure. This is due to the absence of tilling, which ploughs the nutrients into the soil (Andraski et al., 2003). Although the peat had a significantly different bulk density, it was decided to apply the same rate to the peat. The containers were covered with para-film. Throughout this study, water was added intermittently to ensure that approximately 50% field capacity was always maintained.

After 1, 3, 6 and 9 mo, the DM and WEP of the wet soil was first determined. The remaining soil sample was air dried and crushed to pass a 2 mm sieve. Sub-samples were taken, dried at 40 °C for 72 h, and analysed for soil pH and Morgan's P using Morgan's extracting solution.

7.3.4. Statistical analysis

The data (Appendix G) were analysed as a factorial design with soil type, month and treatment as factors. All interactions were examined. Soil type was a blocking effect in this structure, but its interactions with the randomised factors were of interest. The interactions were interpreted in the first instance by testing simple effects and then making comparisons of means, with adjustment for multiplicity of testing. The GLIMMIX procedure of SAS 9.2 was used to fit the analysis model. This procedure allowed the addition of heterogeneous variance structures and a number of options for examining a large number of means. Residual checks were made to check the assumptions of the analysis method.

7.4. Results

7.4.1. Water extractable phosphorus

There was a significant interaction between soil type, month and treatment for WEP ($p < 0.001$). The WEP of incubated soil samples at each sampling time is shown in Figure 7.3. The WEP of the soil-only treatments for the four mineral soils examined was lower after 1 mo of incubation than the WEP of the soil before the start of the experiment. This was in agreement with Kalbasi and Karthikeyan (2004) and Penn and Bryant (2006). This was likely due to the effect of drying and re-wetting, and breaking down of soil as a result of sieving (Penn and Bryant, 2006). In general, the WEP of the soil-only treatment did not vary significantly during the study for soils A, B and E. The WEP of soil C was significantly higher at the 6 mo sampling event than at any other time in the study. The WEP of soil D increased significantly between mo 1 and 3, and stayed steady for the remainder of the study. In contrast, the WEP of the peat soil increased initially as a result of incubation; however, there was no significant variation during the study.

Addition of slurry increased the WEP of soil compared to the soil-only treatment for all soils. This was in agreement with result of other studies (Kalbasi and Karthikeyan, 2004; Murphy, 2007). However, in general, these increases were not statistically significant. The WEP of soil A, when amended with slurry, was significantly different to the soil-only treatment at the 3 mo sampling event. There were also significant differences for soil B (at the 1 and 3 mo sampling times) and for soil D (mo 1) ($p < 0.05$).

For the four mineral soils, alum-amended slurry reduced the average WEP of soil compared to the study control (average of 4 sampling events) by between 52 and 73%, lime by between 50 and 83%, PAC by between 21 and 64%, and FeCl_3 by between 0 and 38%. These reductions in WEP were not consistently statistically significant. After 1 mo of incubation, the WEP of alum-amended slurry was significantly different to the slurry-control for soil B (89%), soil C (98%) and soil D (94%). Lime addition was also effective at reducing WEP compared to the slurry-control and there were significant reductions

after 1 mo for soils B (94%), C (98%) and D (97%) and after 3 mo for soils C (88%) and D (78%). Poly-aluminium chloride was less effective than alum or lime at reducing the WEP compared to the slurry-control with the only significant reductions occurring for soils C (81%) and D (54%) at the 1 mo sampling event. Ferric chloride was less effective than other amendments and much more variable: in soil C, WEP was significantly lower for soil which was mixed with FeCl_3 treated slurry than the slurry-control after 1 mo ($p < 0.05$). After 3 mo, soils A and D were significantly different to the slurry-control ($p < 0.05$). There were no significant differences between WEP of the slurry-control and the soil amended with chemically amended slurry at the 6 and 9 mo sampling event.

7.4.2. Soil test phosphorus

There was a significant interaction between soil type, month and treatment for the STP of the soil ($p < 0.001$). The STP of incubated soil samples at each sampling time are shown in Figure 7.4. The STP of the soil only was observed to be much more stable than the WEP, and did not vary significantly during the course of the experiment. This was consistent with the results of Kalbasi and Karthikeyan (2004). The STP of soils which received dairy cattle slurry also remained relatively stable throughout the course of the experiment and although there were observed differences in STP between the control and soil-only treatments, these differences were not all statistically significant ($p < 0.05$).

For the four mineral soils, during the first month, alum reduced average STP of soil amended with alum-treated slurry compared to the slurry-control by between 13 to 58%, lime by between 0 and 62%, and PAC by between 13 and 46%. Ferric chloride increased STP by up to 30% at 1 mo; this was in agreement with the findings of Kalbasi and Karthikeyan (2004). The STP of the soil amended with alum, lime, PAC and FeCl_3 was greater than the STP for each un-amended soil during the study. Chemical amendments did not have a significant effect on STP of the peat soil. These results indicated that there was no negative effect on plant available P with the use of a chemical amendment, with the exception of soil receiving FeCl_3 amended slurry, the STP of which was significantly different to the slurry-control for soil A (mo 9) and soil B (mo 6 and 9).

Tunney et al. (2000) found a strong association between STP (measured using Morgan's extracting solution) and DRP concentrations in overland flow in Irish grassland soils. This relationship can vary between different hydrological conditions (Kurz et al, 2005) and soil types (Daly et al., 2001). Daly et al (2001) examined 11 soils chosen to best represent important agricultural grassland soils in Ireland varying in parent material, drainage, soil type and soil chemical properties. Daly et al (2001) found that, although STP was an important factor controlling P desorption, soil type also affected levels of sorption and desorption. Regan et al. (2010) found a similar relationship for tillage soils.

7.4.3. Soil pH

There was a significant interaction between soil type, month and treatment for pH of soil ($p < 0.001$). The pH of incubated soil samples at each sampling time are shown in Figure 7.5. The pH of the soil-only treatments did not significantly change as a result of the incubation experiment. Addition of dairy cattle slurry did not significantly alter soil pH for any of the soils examined. With the exception of FeCl_3 (soil A, mo 9) ($p < 0.05$), none of the amendments examined appeared to significantly affect soil pH.

7.5. Discussion

7.5.1. WEP

The results of this study show that although there was an interaction with soil type, treatment and incubation duration, the WEP of soils mixed with chemically amended slurry was generally lower than the un-amended slurry-control. There were some instances where the WEP of soil which was incubated with FeCl_3 amended slurry was greater than the control. Although these increases were not statistically significant, this may indicate that FeCl_3 is not as stable as other amendments examined. These results indicate that chemical amendment may have beneficial impacts on the mitigation of long-term losses of P to surface runoff.

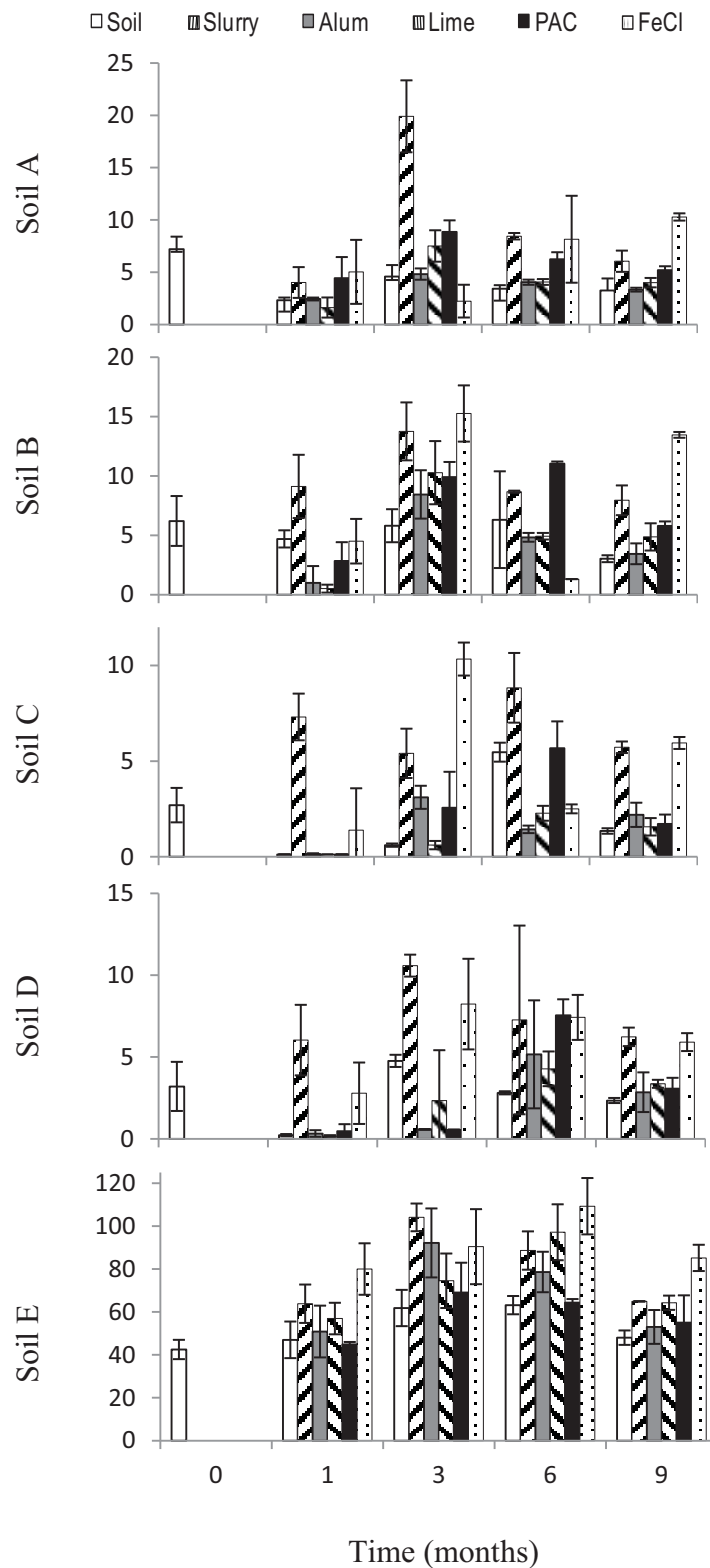

Figure 7.3 Water extractable phosphorus (WEP) of incubated soil samples at each sampling time (n=3)

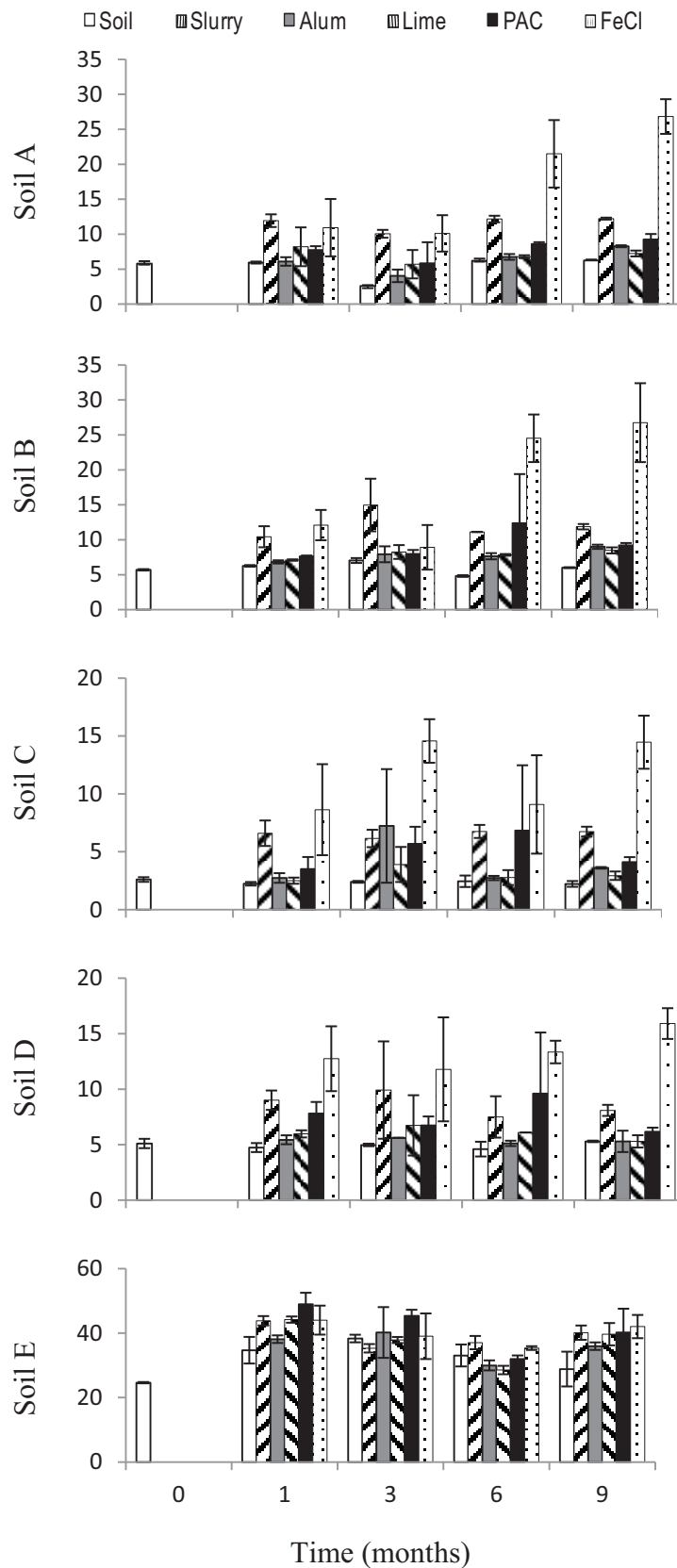

Figure 7.4 Soil test P of incubated soil samples at each sampling time (n=3)

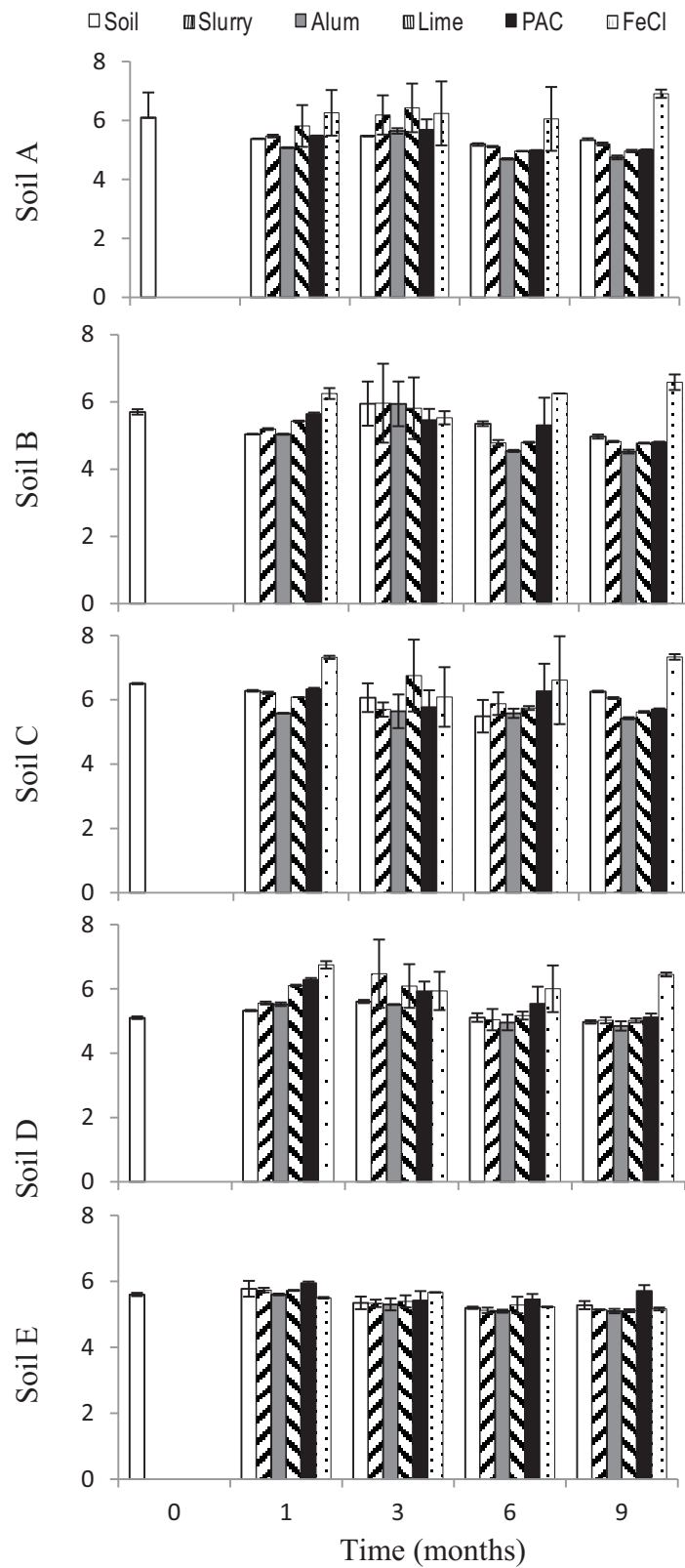

Figure 7.5 pH of incubated soil samples at each sampling time (n=3)

In a similar study, Kalbasi and Karthikeyan (2004) found that application of alum and FeCl_3 decreased P solubility in silt loam soil, while lime amendments increased WEP. This study found that Al-compounds (alum and PAC) reduced WEP in mineral soils. However, FeCl_3 was as effective as the Al compounds, and lime addition resulted in the greatest reduction in WEP. In this study, lime was applied at a higher rate (16:1 compared to 10:1 (Ca:TP) in the Kalbasi and Karthikeyan (2004) study) and this may explain the difference in effectiveness. Anderson et al. (1995) amended soils - with a history of receiving dairy manure - with calcium carbonate (with the slurry pH adjusted to 7.5), gypsum (0 to 100 g kg⁻¹ soil), ferrous sulphate (0 to 1 g kg⁻¹ as Fe) and alum (0 to 1 g kg⁻¹ as Al) in an incubation experiment. Calcium carbonate effectiveness was limited to soils with pH < 7.0 and gypsum was effective over a broad range of manure loading, pH and redox conditions. Although Al and Fe amendments to soil increased P retention by 400% relative to an un-amended control, Anderson et al. (1995) acknowledged elevated costs associated with amendments and the potential for biological toxicity.

Runoff studies have been used to examine the addition of amendments to high STP soils to reduce P losses (McFarland et al, 2003; Novak and Watts, 2005; Brauer et al., 2005). Brauer et al. (2005) incorporated alum (127 kg Al ha⁻¹) and gypsum at two rates (349 and 1163 kg Ca ha⁻¹) into the upper 10 cm of a high STP soil on an annual basis for three years. Only the high gypsum treatment was observed to reduce WEP and STP values significantly during the study. A limited number of runoff studies have been carried out with chemical amendment of dairy cattle slurry (Elliot et al, 2005; Torbert et al, 2005) and swine slurry (Smith et al, 2001b), but little work has focused on the long-term effects of chemical amendments to slurry on the nutrient content of soil.

Although this study gives a good indication of the stability of these amendments in the soil used in this study, it did not examine the effect of chemical amendments on the rate of mineralisation of fixed P to soluble WEP following loss of soluble P in runoff, or in drainage water.

7.5.2. Soil test phosphorus

This study shows that one application of chemically amended slurry does not reduce plant availability of P in the soils examined in this study. In fact, in the case of FeCl_3 , STP was significantly increased for certain soils at the end of the study. This indicates that chemical amendment of dairy cattle may be a short-term management practice to control P surplus on a farm, but does not pose a risk to plant availability of P. In addition, it validates the work of Kalbasi and Karthikeyan (2004) for a range of soils found in Ireland using commercially available amendments. The amendments were buffered by organics in the peat soil examined in this study. In a high OM soil with a pH of 5.5, there is no free Al available, and any metals in the amendments are immediately buffered by organics, which reduces their effectiveness in reducing P solubility. There is a need to examine the effect of repeated applications of slurry amended with chemical amendments on STP and other soil properties.

7.5.3. Soil pH

The pH of the mineral soils receiving FeCl_3 -amended dairy cattle slurry was consistently higher than the slurry-control (Figure 7.5), background and all other treatments. The Cl^- in the FeCl_3 treatment may have replaced OH^- ions on the variable charge exchange sites in these soils, resulting in an increase in pH. This mechanism has been shown on HCl-treated mineral soils with low starting pH and free iron oxides (Wang and Yu, 1998). An elevated soil pH was not measured in soil E. This was likely due to the high buffering capacity and lack of free iron sites in this organic soil.

The national average soil pH is 5.5 for grasslands (Fay et al., 2007), which is below the recommended pH for optimum production of grass (6.3 for mineral soils and 5.5 for peat soils; Coulter and Lalor, 2008). Therefore, the soils examined in this study are representative of the pH range found in Ireland. The pH of a soil has a significant influence on nutrient availability (Tunney et al., 2010), and changes in pH can alter community composition and activity of microbes in soil (Sylvia et al., 2005). In addition,

if the amendments adversely affect the microbes, the microbes could potentially change the pH by their activity. Therefore, pH was examined as a means of determining if the amendments had the potential to have a significant effect on soil microbiology.

7.6. Conclusions

This study found that although there were variations in the reductions in WEP of soil amended with dairy cattle slurry across soil types, the WEP of soil receiving chemically treated dairy cattle slurry was consistently, although not significantly, lower than the slurry-control. Soil test phosphorus and soil pH were not significantly affected by application of amended slurry, with the exception of FeCl_3 amended slurry in some instances. Therefore, chemical amendment of dairy cattle slurry as a short-term management practice to control P loss does not pose a risk to plant availability of soil. There is a need to examine long-term effects of repeated applications of chemically amended dairy cattle slurry to develop an understanding of how amendments affect soil P release processes over time.

7.7. Summary

This study indicates that the use of chemical amendment as a once-off management practice reduced WEP in soil compared to soil amended with slurry, but did not result in immobilisation of STP or have any significant effect on soil physical and chemical properties. Therefore, chemical amendment of dairy cattle slurry as a short-term management practice to control P loss does not pose an immediate risk to plant availability of soil.

Chapter 8 Conclusions and Recommendations

8.1. Overview

The objective of this study was to identify possible mitigation methods to prevent P loss to the environment during the land application of dairy cattle slurry. To address this, experiments were designed and conducted to evaluate the effectiveness, feasibility and pollution swapping potential of chemically amended dairy cattle slurry. The main conclusions of the study are now presented.

8.2. Conclusions

1. Experiments conducted at laboratory micro- and meso-scale, and micro plot-scale showed that chemical amendment was very successful in reducing incidental losses of DRP, TP, PP, TDP, DUP and SS from land-applied slurry. The results of the study demonstrate that PAC was the most effective amendment for decreasing DRP losses in runoff following slurry application, while alum was the most effective for TP and PP reduction. Incidental loss of metals (Al, Ca and Fe) from chemically amended dairy cattle slurry was below the MAC for receiving waters.
2. Although these treatments are expensive, they may be feasible if used strategically to mitigate P loss from dairy slurry in critical source areas within a farm.
3. The results of this study show that even with chemical amendment, P concentration in runoff was above the MAC. Therefore, amendments may not be

the best option for minimising incidental P losses, as timing of applications may be just as effective at controlling incidental P losses and may be much more cost effective.

4. This study showed that P mitigating amendments can result in pollution swapping. The amendments selected for recommendation for further study are, from best to worst, PAC, alum and lime (Table 8.1). In addition, at the current cost of treatment, the increase in fertiliser value of the slurry due to some treatments is not sufficient to offset the cost of treatment. In this study, there was no significant effect of any amendment, with the exception of charcoal, of slurry on GWP caused by the land application dairy cattle slurry.

5. Although there were variations in the reductions in WEP of soil amended with dairy cattle slurry across soil types, the WEP of soil receiving chemically treated dairy cattle slurry was consistently, although not significantly, lower than the slurry-control. Soil test phosphorus and soil pH were not significantly affected by the application of amended slurry, with the exception of FeCl_3 -amended slurry in some instances. Therefore, chemical amendment of dairy cattle slurry as a short-term management practice to control P loss does not pose a risk to plant availability of soil.

Table 8.1 Summary of feasibility of amendments (adapted from Chapter 3). Marks for feasibility, pollution swapping, incubation study and plot study are from 1 to 5. 1 = best; 5 = worst.

Chemical	Agitator score P	Pollution swapping	Incubation study	Plot	Combined feasibility score	Notes
Alum	1	4	1	1	8	Risk of effervescence Risk of release of H ₂ S due to anaerobic conditions and reduced pH Cheap and used widely in water treatment Reduced ammonia emissions
AlCl ₃ (PAC)	2	1	3	2	7	No risk of effervescence (Smith et al., 2004) AlCl ₃ increased handling difficulty Expensive Reduced ammonia emissions
FeCl ₂ (FeCl ₃)	3	3	4	4	14	Potential for Fe bonds to break down in anaerobic conditions Increased release of N ₂ O Reduced ammonia emissions Not examined in plot study
Ca(OH) ₂	4	2	2	3	11	Increased NH ₃ loss Strong odour Hazardous substance Not effective in plot study

8.3. Recommendations for future work

1. This work indicates that if amendments are to be implemented, extensive catchment-scale experiments, carried out over a number of years, are necessary to examine how amendments affect N leaching, plant availability of P, soil microbiology and structure, metal build-up in the soil, long-term release of P to runoff, gaseous emissions and pollution swapping. Such work should use land spreading equipment at farm-scale.
2. These results suggest that chemical amendment of dairy cattle slurry with PAC could be used to control P solubility and thus reduce incidental P losses from soils

receiving dairy cattle slurry without adversely affecting metal and N losses. Future work must examine the long-term stability of metal-to-P bonds formed as a result of chemical amendment of dairy cattle slurry following land application. There is a need to examine the use of chemical amendments to slurry under a wide range of conditions.

3. Results show that a once-off application of any of the chemical amendments examined will not result in a significant change in chemical and chemical properties, an increase in GHG emissions, a release of metals to runoff, or significant pollution swapping. It is, however, critical that the long-term effect of repeated applications of amendments on STP, soil pH, soil WEP, soil microbiology and macro-biology be examined.
4. The results of the gas experiment indicated that if a biochar could be engineered to sequester P as effectively as alum and PAC, it would be the ideal amendment, as charcoal has the potential to dramatically reduce GHG emissions.

8.4. Context

Ireland has committed to meeting the requirements of the European Union Water Framework Directive (EU WFD; 2000/60/EC, OJEC, 2000) to achieve at least ‘good status’ of all surface and groundwater by 2015. It is expected that the current programmes of measures (POM) will not reduce P losses sufficiently within this timeframe and that that substantial measures will be required to fulfil these obligations. While current practices are effective, there will be a time-lag before current changes in farming practices will result in an observable reduction in nutrient losses and reduction in risk to water quality. This study showed that amendments are effective and that there is no major risk of pollution swapping associated with alum and PAC. This is a significant finding as there is now potential to use amendments strategically, in combination with existing programme of measures (POM), to mitigate P losses. The next step will be to examine the use of chemical amendments at catchment-scale.

In future, farm nutrient management in Ireland must focus on examining all farms within a catchment and identifying areas which pose the greatest risk. It is hoped that there will be economic incentives given to farmers to reduce nutrient losses. It is possible that P mitigating methods, such as chemical amendment of dairy cattle slurry, may be used strategically within a catchment to bind P in cow and pig slurries.

REFERENCES

- Abu-Zreig M. Factors affecting sediment trapping in vegetated filter strips: simulation study using VFSMOD. *Hydrological Processes* 2001; 15: 1477-1488.
- Ahuja LR, Sharpley M, Yamamoto M, Menzel RG. The depth of rainfall-runoff soil interaction as determined by ³²P. *Water Resources Research* 1981; 17: 969-974.
- Allen BL, Mallarino AP. Effect of liquid swine manure rate, incorporation, and timing of rainfall on phosphorus loss with surface runoff. *Journal of Environmental Quality* 2008; 37: 125-137.
- Amon B, Kryvoruchko V, Amon T, Zechmeister-Boltenstern S. Methane, nitrous oxide and ammonia emissions during storage and after application of dairy cattle slurry and influence of slurry treatment. *Agriculture, Ecosystems and Environment* 2006; 112: 153-162.
- Anderson DL, Tuovinen OH, Faber A, Ostrokowski I. Use of soil amendments to reduce soluble phosphorus in dairy soils. *Ecological Engineering* 1995; 5: 229-246.
- Andraski TW, Bundy LG, Kilian KC. Manure history and long-term tillage effects on soil properties and phosphorus losses in runoff. *Journal of Environmental Quality* 2003; 32: 1782-1789.
- Anon. Joint committee on communications, energy and natural resources forth report: The development of anaerobic digestion in Ireland. Available at: <http://www.oireachtas.ie/viewdoc.asp?DocID=17463&CatID=78>, verified 12th July 2011.
- Anon. Management data for Farm Planning 2008, Teagasc, Oak Park, Carlow, 2008.
- APHA. Standard methods for the examination of water and wastewater. American Public Health Association (APHA), Washington 1995.
- Asada T, Ishihara S, Yamane T, Toba A, Yamada A, Oilkawa K. Science of bamboo charcoal: study on carbonizing temperature of bamboo charcoal and removal capability of harmful gases. *Journal of Health Science* 2002; 48: 473-479.
- Barrow JT, Van Horn HH, Anderson DL, Nordstedt RA. Effects of Fe and Ca additions to dairy wastewaters on solids and nutrient removal by sedimentation. *Applied Engineering in Agriculture* 1997; 13: 259-267.

- Batchelor GK. An introduction to Fluid Dynamics. Cambridge University Press. ISBN 0521663962 1967)
- Bond CR, Maguire RO, Havlin JL. Change in soluble phosphorus in soils following fertilisation is dependent on initial Mehlich-3 phosphorus. *Journal of Environmental Quality* 2006; 35: 1818-1824.
- Borin M, Vianello M, Morari F, Zanin G. Effectiveness of buffer strips in removing pollutants in runoff from a cultivated field in North-East Italy. *Agriculture, Ecosystems and Environment* 2005; 105: 101-114.
- Bowyer-Bower TAS, Burt TP. Rainfall simulators for investigating soil response to rainfall. *Soil Technology* 1989; 2: 1-16.
- Brauer D, Aiken GE, Pote DH, Livingston SJ, Norton LD, Way TR, Edwards JH. Amendment effects on soil test phosphorus. *Journal of Environmental Quality* 2005; 34: 1682-1686.
- Bray RH, Kurtz LT. Determination of total, organic, and available forms of P in soils. *Soil Science* 1945; 59: 39-45.
- British Standards. British standard methods of test for soils for civil engineering purposes. Determination of particle size distribution. BS 1377:1990:2. BSI, London, 1990a.
- British Standards. Determination by mass-loss on ignition. British standard methods of test for soils for civil engineering purposes. Chemical and electro-chemical tests. BS 1377:1990:3. BSI, London, 1990b.
- Bryant RB, Anthony Buda PA, Kleinman P, Church C, McGrath J, Grubb K, Bose S. Using FGD Gypsum to remove soluble phosphorus from agricultural drainage waters. (Ed. Buda AR) In: ASA, CSSA, and SSSA 2010 International annual meetings. Symposium-Emerging technologies to remove phosphorus from surface and groundwater, Long Beach, CA, Available at: <http://a-c-s.confex.com/crops/2010am/webprogram/Paper60537.html>, verified 22nd September 2011, 2010.
- Buda AR, Kleinman PJ, Bryant RB, Feyereisen GW. Effects of hydrology and field management on phosphorus transport in surface runoff. *Journal of Environmental Quality* 2009; 38: 2273-2284.

- Buda AR, Koopmans G, Chardon W, Bryant RB. Emerging technologies to remove nonpoint phosphorus sources from surface water and groundwater In: ASA, CSSA, and SSSA 2010 International annual meetings. Symposium-Emerging technologies to remove phosphorus from surface and groundwater, Long Beach, CA, Available at: <http://a-c-s.confex.com/crops/2010am/webprogram/Paper60515.html>, verified 22nd September 2011, 2010.
- Byrne E. Chemical analysis of agricultural materials – methods used at Johnstown Castle Research Centre, Wexford. Published by An Foras Taluntais, 1979.
- Cao X, Harris W. Properties of dairy-manure-derived biochar pertinent to its potential use in remediation. *Bioresource Technology* 2010; 101: 5222-5228.
- Common Agriculture Programme, Rural Development Programme Ireland 2007-2013. Inclusive of amendments of 30th September 2008 and of 15th May 2009. Amendments to Indicators 16th June 2009 and amendments to RDP of 15th July 2009. Inclusive of amendments to RDP of 12th November, 23rd December 2009 and 11th January 2010. Available at: <http://www.environ.ie/en/Publications/Community/RuralDevelopment/FileDownload,26515,en.pdf> verified 28 June 2011. 2011.
- Carney K, Rodgers M, Zhan X, Lawlor P. A sustainable technology for the treatment of piggery wastewaters. In proceedings Global Conference on Global Warming-2011 (GCGW-11), July 11th - 14th 2011, Lisbon, Portugal., 2011.
- Carpenter SR, Caraco NF, Correll DL, Howarth RW, Sharpley AN, Smith VH. Nonpoint pollution of surface waters with phosphorus and nitrogen. *Ecological Applications* 1998; 8: 559-568.
- Chadwick D, Pain BF. Methane fluxes following slurry applications to grassland soils: laboratory experiments. *Agriculture, Ecosystems and Environment* 1997; 63: 51-60.
- Chadwick DR, Pain BF, Brookman SKE. Nitrous oxide and methane emissions following application of animal manures to grassland. *Journal of Environmental Quality* 2000; 29: 277-287.
- Clemens J, Trimborn M, Weiland P, Amon B. Mitigation of greenhouse gas emissions by anaerobic digestion of cattle slurry. *Agriculture, Ecosystems and Environment* 2006; 112: 171-177.

- Clough TJ, Condon LM. Biochar and the Nitrogen Cycle: introduction. *Journal of Environmental Quality* 2010; 39: 1218-1223.
- Correll DL. The role of phosphorus in the eutrophication of receiving waters: a review. *Journal of Environmental Quality* 1998; 27: 261-266.
- Côté C, Massé DI, Quessy S. Reduction of indicator and pathogenic microorganisms by psychrophilic anaerobic digestion in swine slurries. *Bioresource Technology* 2006; 97: 686-691.
- Cottenie A, Kiekens L. Report of results of the inter-laboratory comparison: determination of the mobility of heavy metals in soils. (Eds. Hermite PL, Ott HD). In: *Processing and use of sewage sludge*. Reidel, Publishing, The Netherlands, 1984.
- Coulter BS, Lalor S. Major and micro nutrient advice for productive agricultural crops. 3rd Teagasc Johnstown Castle Wexford. pp. 116, 2008.
- CSO. Crops and Livestock Survey June 2008-Final Results. Central Statistics Office, Skehard Road, Cork, Ireland. 2009: 9.
- CSO. Livestock survey, February 2006. Central Statistics Office. Available at: www.cso.ie, verified 20th September 2011, 2006.
- Cummins T, Farrell EP. Biogeochemical impacts of clearfelling and reforestation on blanket peatland streams. I. Phosphorus. *Forest Ecology Management* 2003; 180: 545-555.
- DAFF. Compendium of Irish agricultural statistics. Department of Agriculture and Food, Wexford, 2008
- Daly K, Casey A. Environmental aspects of soil phosphorus testing. *Irish Journal of Agricultural and Food Research* 2005; 44: 261-279.
- Daly K, Jeffrey D, Tunney H. The effect of soil type on phosphorus sorption capacity and desorption dynamics in Irish grassland soils. *Soil Use and Management* 2001; 17: 12-20.
- Dao TH. Co-amendments to modify phosphorus extractability and nitrogen/phosphorus ration in feedlot manure and composted manure. *Journal of Environmental Quality* 1999; 28: 1114-1121.

- Dao TH, Daniel TC. Particulate and dissolved phosphorus chemical separation and phosphorus release from treated dairy manure. *Journal of Environmental Quality* 2002; 31: 1388-1398.
- Dayton EA, Basta NT. Characterisation of drinking water treatment residuals for use as a soil substitute. *Water Environment Research* 2001; 71: 52-57.
- Dayton EA, Basta NT. Use of drinking water treatment residuals as a potential best management practice to reduce phosphorus risk index scores. *Journal of Environmental Quality* 2005; 34: 2112-2117.
- DeLaune PB, Moore PA, Jr., Carman DK, Sharpley AN, Haggard BE, Daniel TC. Evaluation of the phosphorus source component in the phosphorus index for pastures. *Journal of Environmental Quality* 2004; 33: 2192-2200.
- Ding Y, Liu YX, Wu WX, Shi DZ, Yang M, Zhong ZK. Evaluation of Biochar effects on nitrogen retention and leaching in multi-layered soil columns. *Water, Air and Soil Pollution* 2011; 213: 47-55.
- Dorioz JM, Wang D, Poulenard J, Trévisan D. The effect of grass buffer strips on phosphorus dynamics-A critical review and synthesis as a basis for application in agricultural landscapes in France. *Agriculture, Ecosystems and Environment* 2006; 117: 4-21.
- Dou Z, Zhang GY, Stout WL, Toth JD, Ferguson JD. Efficacy of alum and coal combustion by-products in stabilizing manure phosphorus. *Journal of Environmental Quality* 2003; 32: 1490-1497.
- Dougherty WJ, Nicholls PJ, Milham PJ, Havilah EJ, Lawrie RA. Phosphorus fertilizer and grazing management effects on phosphorus in runoff from dairy pastures. *Journal of Environmental Quality* 2008; 37: 417-428.
- Edwards DR, Daniel TC. Drying interval effects on runoff from fescue plots receiving swine manure. *Transactions of the ASABE* 1993; 36: 1673-1678.
- Edwards DR, Moore PA, Workman SR, Bushee EL. Runoff of metals from alum-treated horse manure and municipal sludge. *Journal of American Water Resources Association* 1999; 35: 155-165.
- EEC. S.I. 293 of 1988 Salmonid water quality standards, 1988.

- EEC. S.I. No. 294/1989 Quality of surface water intended for the abstraction of drinking water, 1989.
- EEC. Council Directive concerning the protection of waters against pollution caused by nitrates from agricultural sources. Council of the European Communities, 91/676/EEC, 1991.
- Eghball B, Gilley JE. Phosphorus and nitrogen in runoff following beef cattle manure or compost application. *Journal of Environmental Quality* 1999; 28: 1201-1210.
- Elliott H, Brandt R, O'Connor GA. Runoff phosphorus losses from surface-applied biosolids. *Journal of Environmental Quality* 2005; 34: 1632-1639.
- Ellis S, Yamulki S, Dixon E, Harrison R, Jarvis SC. Denitrification and N₂O emissions from a UK pasture soil following the early spring application of cattle slurry and mineral fertiliser. *Plant and Soil* 1998; 202: 15-25.
- EPA. Environmental Protection Agency: trends in NH₃ emissions 2008. Environmental Protection Agency. Available at:
<http://www.epa.ie/environment/air/emissions/ammonia/>, verified 22th September 2011, 2010.
- Fay D, Kramers G, Zhang C, McGrath D, Grennan E. Soil geochemical atlas of Ireland. Teagasc and the Environmental Protection Agency, Dublin; 2007.
- Fenton O, Healy MG, Schulte RPO. A review of remediation and control systems for the treatment of agricultural wastewater in Ireland to satisfy the requirements of the Water Framework Directive. *Biology and Environment: Proceedings of the Royal Irish Academy* 2008; 108: 69-79.
- Fenton O, Healy MG, Rodgers M. Use of ochre from an abandoned metal mine in the south east of Ireland for phosphorus sequestration from dairy dirty water. *Journal of Environmental Quality* 2009; 38: 1120-5.
- Ferm M. Atmospheric ammonia and ammonium transport in Europe and critical loads: a review. *Nutrient Cycling in Agroecosystems* 1998; 51: 5-17.
- Fingelton WA, Cushion M. Irish agriculture in Figures 1998. Teagasc, Dublin.
www.teagasc.ie, 1999.

- Flanagan PJ. Water quality regulations are legal guidelines used to safeguard public health. 'Parameters of Water Quality', Environmental Research Unit, Dublin 4. , 1990.
- Frossard E, Condrón LM, Oberson A, Sinaj S, Fardeau JC. Processes governing phosphorus availability in temperate soils. *Journal of Environmental Quality* 2000; 29: 15-23.
- Frost P, Gilkinson S. Interim technical report: first 18 month performance summary for anaerobic digestion of dairy cattle slurry at Hillsborough. Available at: <http://www.afbini.gov.uk/afbi-ad-18-months-v05.pdf>, verified 12th July 2011, 2010.
- Gaunt J, Lehmann J. Energy balance and emissions associated with biochar sequestration and pyrolysis bioenergy production. *Environmental Science and Technology* 2008; 42: 4152-4158.
- Gay SW, Knowlton KF. Ammonia emissions and animal agriculture. Virginia Cooperative Extension. Biological Systems Engineering Publication No. 442-110. Available at: http://pubs.ext.vt.edu/442/442-110/442-110_pdf.pdf verified 7 September 2011, 2005.
- Génermont S, Cellier P. A mechanistic model for estimating ammonia volatilization from slurry applied to bare soil. *Agricultural and Forest Meteorology* 1997; 88: 145-167.
- Gilkinson S, Frost P. Evaluation of mechanical separation of pig and cattle slurries by a decanting centrifuge and a brushed screen separator. AFBI-Hillsborough, September, 2007.
- Goulding KWT, Bailey NJ, Bradbury NJ, Hargreaves P, Howe M, Murphy DV, Poulton PR, Willison TW. Nitrogen deposition and its contribution to nitrogen cycling and associated soil processes. *New Phytologist* 1998; 139: 49-58.
- Güngör K, Karthikeyan KG. Phosphorus forms and extractability in dairy manure: A case study for Wisconsin on-farm anaerobic digesters. *Bioresource Technology* 2008; 99: 425-436.
- Hanrahan LP, Jokela WE, Knapp JR. Dairy diet phosphorus and rainfall timing effects on runoff phosphorus from land-applied manure. *Journal of Environmental Quality* 2009; 38: 212-217.

- Hart MR, Quin BF, Nguyen ML. Phosphorus runoff from agricultural land and direct fertilizer effects. *Journal of Environmental Quality* 2004; 33: 1954-1972.
- Haygarth PM, Hepworth L, Jarvis SC. Forms of phosphorus transfer in hydrological pathways from soil under grazed grassland. *European Journal of Soil Science* 1998; 49: 65-72.
- Healy MG, Cawley AM. Performance of a constructed wetland in western Ireland. *Journal of Environmental Quality* 2002; 17: 1739-1747.
- Healy MG, Rodgers M, Mulqueen J. Recirculating sand filters for treatment of synthetic dairy parlor washings. Vol 33. Madison, WI, ETATS-UNIS: American Society of Agronomy, 2004.
- Healy MG, Rodgers M, Mulqueen J. Treatment of dairy wastewater using constructed wetlands and intermittent sand filters. *Bioresource Technology* 2007; 98: 2268-2281.
- Heathwaite AL, Griffiths P, Parkinson RJ. Nitrogen and phosphorus in runoff from grassland with buffer strips following application of fertilizers and manures. *Soil Use and Management* 1998; 14: 142-148.
- Henry CG, Harner JP, Strahm TD, Reynolds MA. Application and performance of constructed wetlands for runoff from small operations. *Biological Systems Engineering* 2003.
- Hoffmann CC, Kjaergaard C, Uusi-Kämpä J, Hansen HCB, Kronvang B. Phosphorus retention in riparian buffers: review of their efficiency. *Journal of Environmental Quality* 2009; 38: 1942–1955.
- Holm-Nielsen JB, Al Seadi T, Oleskowicz-Popiel P. The future of anaerobic digestion and biogas utilization. *Bioresource Technology* 2009; 100: 5478-5484.
- Horton. The role of infiltration in the hydrological cycle. *Transactions, American, Geophysical Union*, 1933.
- Humphreys J, Tunney H, Duggan P. Soil analyses and comparison of soil phosphorus tests for the Bellsgrave catchment, Cavan. End of project report. Project 4366. Johnstown Castle, Research Center, Wexford, 1999.

- Husted S, Jensen LS, Jørgensen SS. Reducing ammonia loss from cattle slurry by the use of acidifying additives: The role of the buffer system. *Journal of the Science of Food and Agriculture* 1991; 57: 335-349.
- Hyde BP, Carton OT. Manure management facilities on farms and their relevance to efficient nutrient use. The Fertilizer Association of Ireland. Available at: [http://www.fertilizer-
assoc.ie/publications/Manure_management_facilities_B_Hyde_O_Carton.pdf](http://www.fertilizer-
assoc.ie/publications/Manure_management_facilities_B_Hyde_O_Carton.pdf), verified 22th September 2011, 2005.
- Hyde BP, Carton OT, O'Toole P, Misselbrook TH. A new inventory of ammonia emissions from Irish agriculture. *Atmospheric Environment* 2003; 37: 55-62.
- IPCC. Intergovernmental panel on climate change—climate change 1995. (Eds. Houghton JT, Jenkins GJ, Ephraums JJ.) In: *Science of Climate Change*. The Cambridge University Press, Cambridge, UK, 1996.
- Iyobe T, Asada T, Kawata K, Oikawa K. Comparison of removal efficiencies for ammonia and amine gases between woody charcoal and activated carbon. *Journal of Health Science* 2004; 50: 148-153.
- Jamieson TS, Stratton GW, Gordon R, Madani A. Phosphorus adsorption characteristics of a constructed wetland soil receiving dairy farm wastewater. *Canadian Journal of Soil Science* 2002; 82: 97-104.
- Johnes PJ, Foy R, Butterfield D, Haygarth PM. Land use for England and Wales: evaluation of management options to support 'good ecological status' in surface freshwaters. *Soil Use and Management* 2007; 23: 176-196.
- Kai P, Pedersen P, Jensen JE, Hansen MN, Sommer SG. A whole-farm assessment of the efficacy of slurry acidification in reducing ammonia emissions. *European Journal of Agronomy* 2008; 28: 148-154.
- Kalbasi M, Karthikeyan KG. Phosphorus dynamics in soils receiving chemically treated dairy manure. *Journal of Environmental Quality* 2004; 33: 2296-2305.
- Karpiscak MM, Freitas RJ, Gerba CP, Sanchez LR, Shamir E. Management of dairy waste in the Sonoran Desert using constructed wetland technology. *Water Science and Technology* 1999; 40: 57-65.

- Kasimir-Klemedtsson Å, Klemedtsson L, Berglund K, Martikainen P, Silvola J, Oenema O. Greenhouse gas emissions from farmed organic soils: a review. *Soil Use and Management* 1997; 13: 245-250.
- Ketterings Q, Meisinger JJ, Chase L. The Nitrogen Cycle. Nutrient management on dairy farms, Department of Crop and Soil Sciences, Cornell University. Available at: <http://www.dairyn.cornell.edu/pages/20cropsoil/23cycle.shtml>. Verified 7th September 2011, 2011.
- Kissel DE, Brewer HL, Arkin GF. Design and test of a field sampler for ammonia volatilisation. *Soil Science Society of America Journal* 1977; 41: 1133-1138.
- Kleinman PJA, Sharpley AN. Effect of broadcast manure on runoff phosphorus concentrations over successive rainfall events. *Journal of Environmental Quality* 2003; 32: 1072-1081.
- Kleinman PJA, Srinivasan MS, Dell CJ, Schmidt JP, Sharpley AN, Bryant RB. Role of rainfall intensity and hydrology in nutrient transport via surface runoff. *Journal of Environmental Quality* 2006; 35: 1248-1259.
- Kleinman PJA, Sullivan D, Wolf A, Brandt R, Dou Z, Elliott H, Kovar J, Leytem A, Maguire R, Moore P, Saporito L, Sharpley AN, Shober A, Sims T, Toth J, Toor G, Zhang H, Zhang T. Selection of a water extractable phosphorus test for manures and biosolids as an indicator of runoff loss potential. *Journal of Environmental Quality* 2007; 36: 1357-1367.
- Knight RL, Payne JVWE, Borer RE, Clarke JRA, Pries JH. Constructed wetlands for livestock management. *Ecological Engineering* 2000; 15: 41-55.
- Kramers G, Richards KG, Holden NM. Assessing the potential for the occurrence and character of preferential flow in three Irish grassland soils using image analysis. *Geoderma* 2009; 153: 362-371.
- Kronvang B, Jeppesen E, Conley DJ, Søndergaard M, Larsen SE, Ovesen NB, Carstensen J. Nutrient pressures and ecological responses to nutrient loading reductions in Danish streams, lakes and coastal waters. *Journal of Hydrology* 2005; 304: 274-288.
- Kronvang B, Rubaek GH, Heckrath G. International Phosphorus Workshop: Diffuse phosphorus loss to surface water bodies - risk assessment, mitigation options, and

- ecological effects in river basins. *Journal of Environmental Quality* 2009; 38: 1924-1929.
- Krumpleman BW, Daniel TC, Edwards FG, McNew RW, Miller DM. Optimum coagulant and flocculant concentrations for solids and phosphorus removal from pre-screened flushed dairy manure. *Applied Engineering in Agriculture* 2005; 21: 127-135.
- Kurz I, Coxon C, Tunney H, Ryan D. Effects of grassland management practices and environmental conditions on nutrient concentrations in overland flow. *Journal of Hydrology* 2005; 304: 35-50.
- Kurz I, O'Reilly CD, Tunney H. Impact of cattle on soil physical properties and nutrient concentrations in overland flow from pasture in Ireland. *Agriculture, Ecosystems and Environment* 2006; 113: 378-390.
- Kwapinski W, Byrne C, Kryachko E, Wolfram P, Adley C, Leahy JJ, Novotny EH, Hayes MHB. Biochar from biomass and waste. *Journal Waste and Biomass Valorization* 2010; 1: 177-189.
- Lalor S. Economical costs and benefits of adoption of the trailing shoe slurry application method on grassland farms in Ireland. (Ed. Koutev V) In: 13th RAMIRAN International conference: Potential for simple technology solutions in organic manure management, pp. 75–80. Albena, Bulgaria, 2008, pp. 75-80.
- Lalor STJ, Schulte RPO. Low-ammonia-emission application methods can increase the opportunity for application of cattle slurry to grassland in spring in Ireland. *Grass and Forage Science* 2008a; 63: 531-544.
- Lalor STJ, Schulte RPO. Nitrogen fertilizer replacement value of cattle slurry applied to grassland. Teagasc, Johnstown Castle, Booklet of 'Slurry and nutrient efficiency display', 1 May 2008, 2008b.
- Lefcourt AM, Meisinger JJ. Effect of adding alum or zeolite to dairy slurry on ammonia volatilisation and chemical composition. *Journal of Dairy Science* 2001; 84: 1814-1821.
- Lehmann J, Joseph S. Biochar for environmental management: science and technology. In: Earthscan, London. Available at:

- http://www.biochar-international.org/images/Biochar_book_Chapter_1.pdf, verified 13th September 2011, 2009.
- Little JL, Nolan SC, Casson JP, Olson BM. Relationships between soil and runoff phosphorus in small Alberta watersheds. *Journal of Environmental Quality* 2007; 36: 1289-1300.
- Luederitz V, Eckert E, Lange-Weber M, Lange A, Gersberg RM. Nutrient removal efficiency and resource economics of vertical flow and horizontal flow constructed wetlands. *Ecological Engineering* 2001; 18: 157-171.
- Mantovi P, Marmiroli M, Maestri E, Tagliavini S, Piccinini S, Marmiroli N. Application of a horizontal subsurface flow constructed wetland on treatment of dairy parlor wastewater. *Bioresource Technology* 2003; 88: 85-94.
- Martínez-Suller L, Provolo G, Brennan D, Howlin T, Carton OT, Lalor STJ, Richards KG. A note on the estimation of nutrient value of cattle slurry using easily determined physical and chemical parameters. *Irish Journal of Agricultural and Food Research* 2010; 49: 93-97.
- Massé DI, Gilbert Y, Topp E. Pathogen removal in farm-scale psychrophilic anaerobic digesters processing swine manure. *Bioresource Technology* 2010; 102: 641-646.
- Massé DI, Talbot G, Gilbert Y. On farm biogas production: A method to reduce GHG emissions and develop more sustainable livestock operations. *Animal Feed Science and Technology* 2011; 166: 436-445.
- Mayer PM, Reynolds SK, McCutchen MD, Canfield TJ. Riparian buffer width, vegetative cover, and nitrogen removal effectiveness: a review of current science and regulations. EPA/600/R-05/118. Cincinnati, OH, U.S. Environmental Protection Agency. Available at: <http://www.epa.gov/nrmrl/pubs/600R05118/600R05118.pdf>, verified 12th July 2011, 2006.
- McBride MB. Chemisorption and precipitation reactions. (Eds. Sumner ME) In: *Handbook of Soil Science*. CRC Press. Boca Raton, FL, 2000; p. B-265 - B-302.
- McDowell R, Sharpley A. Phosphorus transport in overland flow in response to position of manure application. *Journal of Environmental Quality* 2002a; 31: 217-227.

- McDowell RW, Sharpley AN. Soil phosphorus fractions in solution: influence of fertiliser and manure, filtration and method of determination. *Chemosphere* 2001; 45: 737-748.
- McDowell RW, Sharpley AN. Effect of plot-scale and an upslope phosphorus source on phosphorus loss in overland flow. 18. Blackwell Publishing Ltd, 2002b, pp. 112-119.
- McDowell RW, Sharpley AN, Bourke W. Treatment of drainage water with industrial by-products to prevent phosphorus loss from tile-drained land. *Journal of Environmental Quality* 2008; 37: 1575-1582.
- McFarland AMS, Hauck LM, Kruzic AP. Phosphorus reductions in runoff and soils from land-applied dairy effluent using chemical amendments: An observation. *The Texas Journal of Agriculture and Natural resource* 2003: 47-59.
- McGarrigle M, Lucey J, O Cinneide M. Water quality in Ireland 2007-2009. Environmental Protection Agency, Johnstown Castle, Wexford, Ireland, 2011.
- McGettigan M, Duffy P, Hyde B, Hanley E, O'Brien P, Ponzi J, Black K. National inventory report 2009: Greenhouse gas emissions 1990 – 2010 reported to the United Nations framework convention on climate change. Environmental Protection Agency, Co. Wexford, Ireland. Available at: <http://coe.epa.ie/ghg/nirdownloads.jsp>, 2010, verified 12th June 2011.
- McKergow LA, Weaver DM, Prosser IP, Grayson RB, Reed AEG. Before and after riparian management: sediment and nutrient exports from a small agricultural catchment, Western Australia. *Journal of Hydrology* 2003; 270: 253-272.
- Mehlich A. Mehlich 3 soil test extractant: A modification of the Mehlich 2 extractant. *Communications in Soil Science and Plant Analysis* 1984; 15: 1409-1416.
- Meisinger JJ, Lefcourt AM, Van Kessel J, Ann S., Wilkerson V. Managing ammonia emissions from dairy cows by amending slurry with alum or zeolite or by diet modification. *Proceedings of the 2nd International Nitrogen Conference on Science and Policy*, 2001.
- Miller JJ, Olson ECS, Chanasyk DS, Beasley BW, Larney FJ, Olson BM. Phosphorus and nitrogen in rainfall simulation runoff after fresh and composted beef cattle manure application. *Journal of Environmental Quality* 2006; 35: 1279-1290.

- Misselbrook T, Powell JM, Broderick GA, Grabber JH. Dietary manipulation in dairy cattle: Laboratory experiments to assess the influence on ammonia emissions. *Journal of Dairy Science* 2005; 88: 1765-1777.
- Misselbrook TH, Van Der Weerden TJ, Pain BF, Jarvis SC, Chambers BJ, Smith KA, Phillips VR, Demmers TGM. Ammonia emission factors for UK agriculture. *Atmospheric Environment* 2000; 34: 871-880.
- Moller HB, Hansen JD, Sorensen CAG. Nutrient recovery by solid-liquid separation and methane productivity of solids. *Transactions of the ASABE* 2007; 50: 193-200.
- Möller K, Stinner W. Effects of different manuring systems with and without biogas digestion on soil mineral nitrogen content and on gaseous nitrogen losses (ammonia, nitrous oxides). *European Journal of Agronomy* 2009; 30: 1-16.
- Möller K, Stinner W, Deuker A, Leithold G. Effects of different manuring systems with and without biogas digestion on nitrogen cycle and crop yield in mixed organic dairy farming systems. *Nutrient Cycling in Agroecosystems* 2008; 82: 209-232.
- Molloy SP, Tunney H. A laboratory study of ammonia volatilization from cattle and pig slurry. *Irish Journal of Agricultural Research* 1983; 22: 37-45.
- Moore PA, Jr., Daniel TC, Edwards DR. Reducing phosphorus runoff and inhibiting ammonia loss from poultry manure with aluminum sulfate. *Journal of Environmental Quality* 2000; 29: 37-49
- Moore PA, Jr., Daniel TC, Gilmour JT, Shreve BR, Edwards DR, Wood BH. Decreasing metal runoff from poultry litter with aluminium sulphate. *Journal of Environmental Quality* 1998; 27: 92-99.
- Moore PA, Edwards DR. Long-term effects of poultry litter, alum-treated litter and ammonium nitrate on aluminium availability in soils. *Journal of Environmental Quality* 2005; 34: 2104-2111.
- Moore PA, Jr., Daniel TC, Edwards DR. Reducing phosphorus runoff and improving poultry production with alum. *Poultry Science* 1999; 78: 692-698.
- More SJ. Global trends in milk quality: implications for the Irish dairy industry. *Irish Veterinary Journal* 2009; 62: 5-14.

- Morgan MF. Chemical soil diagnosis by the Universal Soil Testing System. Connecticut. Connecticut agricultural Experimental Station Bulletin 450 Connecticut. New Haven, 1941.
- Mulqueen J, Rodgers M, Scally P. Phosphorus transfer from soil to surface waters. *Agricultural Water Management* 2004; 68: 91-105.
- Narvanen A, Jansson H, Uusi-Kamppa J, Jansson H, Perala P. Phosphorus load from equine critical source areas and its reduction using ferric sulphate. *Boral Environment Research* 2008; 13: 265-274.
- Novak JM, Busscher WJ, Watts DW, Laird DA, Ahmedna MA, Niandou MAS. Short-term CO₂ mineralization after additions of biochar and switchgrass to a Typic Kandiudult. *Geoderma* 2010; 154: 281-288.
- Novak JM, Watts DW. An alum-based water treatment residual can reduce extractable phosphorus concentrations in three phosphorus-enriched coastal plain soils. *Journal of Environmental Quality* 2005; 34: 1820-1827.
- O'Rourke SM, Foy RH, Watson CJ, Ferris CP, Gordon A. Effect of varying the phosphorus content of dairy cow diets on losses of phosphorus in overland flow following surface applications of manure. *Journal of Environmental Quality* 2010; 39: 2138-2146.
- O'Connor G, Elliott H, Agyin-Birikorang S. Amendments to Control Phosphorus Mobility. (Ed. Turtola E) In: Proceedings of the COST 869 WG2 / WG3 meeting in Jokioinen, Finland, 14th-16th June 2010. Available at: <http://www.cost869.alterra.nl/Finland/OConnor.pdf>, verified 8th September 2011, 2010.
- O'Neill B, Grossman J, Tsai M, Gomes J, Lehmann J, Peterson J, Neves E, Thies JE. Bacterial community composition in Brazilian Anthrosols and adjacent soils characterized using culturing and molecular identification. *Microbial Ecology* 2009; 58: 23-35.
- OJEC. Official Journal of the European Communities, 2000. Directive 2000/60/EC of the European Parliament and of the council of 23th October 2000 establishing a framework for Community action in the field of water policy 2000.

- OJEC. Official Journal of the European Community. Directive 2006/118/EC of the European Parliament and of the council of 12th December 2006 on the pollution of ground water against pollution and deterioration, 2006.
- Olsen SR, Cole CV, Watanabe FS, Dean LA. Estimation of available phosphorus in soils by extraction with sodium bicarbonate. U.S. Dept of Agriculture Washington D.C. 1954.
- Olsen SR, Watanabe FS. A method to determine a phosphorus absorption maximum of soils as measured by the Langmuir isotherm. *Soil Science Society Proceedings* 1957; 31: 144-149.
- Oya A, Iu WG. Deodorization performance of charcoal particles loaded with orthophosphoric acid against ammonia and trimethylamine. *Carbon* 2002; 40: 1391-1399.
- Pain BF, Misselbrook TH, Clarkson CR, Rees YJ. Odour and ammonia emissions following the spreading of anaerobically-digested pig slurry on grassland. *Biological Wastes* 1990; 34: 259-267.
- Pain BF, Phillips VR, Clarkson CR, Klarenbeek JV. Loss of nitrogen through ammonia volatilisation during and following the application of pig or cattle manure to grassland. *Journal of the Science of Food and Agriculture* 1989; 47: 1-12.
- Parkinson R, Gibbs P, Burchett S, Misselbrook T. Effect of turning regime and seasonal weather conditions on nitrogen and phosphorus losses during aerobic composting of cattle manure. *Bioresource Technology* 2004; 91: 171-178.
- Pattey E, Trzcinski M, Desjardins R. Quantifying the reduction of greenhouse gas emissions as a result of composting dairy and beef cattle manure. *Nutrient Cycling in Agroecosystems* 2005; 72: 173-187.
- Penn CJ, Bryant RB. 'Incubation of dried and sieved soils can induce calcium phosphate precipitation/adsorption'. *Communications in Soil Science and Plant Analysis* 2006; 37:9,1437-1449.
- Penn CJ, Bryant RB, Callahan MA, McGrath JM. Use of industrial by-products to sorb and retain phosphorus. *Communications in Soil Science and Plant Analysis* 2011; 42: 633-644.

- Penn CJ, McGrath JM. Predicting phosphorus sorption onto steel slag using a flow-through approach with application to a pilot scale system. *Journal of Water Resource and Protection* 2011; 3: 235-244.
- Pionke HB, Gburek WJ, Sharpley AN. Critical source area controls on water quality in an agricultural watershed located in the Chesapeake Basin. *Ecological Engineering* 2000; 14: 325-335.
- Pote DH, Lory JA, Zhang H. Does initial soil P level affect water-extractable soil P response to applied P? *Advances in Environmental Research* 2003; 7: 503-509.
- Power JF, Schepers JS. Nitrate contamination of groundwater in North America. *Agriculture, Ecosystems and Environment* 1989; 26: 165-187.
- Powers WJ, Montoya RE, Van Horn HH, Nordstedt RA, Bucklin RA. Separation of manure solids from simulated flushed manures by screening or sedimentation. *Applied Engineering in Agriculture* 1995; 11: 431-436.
- Pratt PF, Blair FL. Buffer method for estimating lime and sulphur applications for pH control of soils. *Soil Science* 1963; 93: 329.
- Preedy N, McTiernan K, Matthews R, Heathwaite L, Haygarth P. Rapid incidental phosphorus transfers from grassland. *Journal of Environmental Quality* 2001; 30: 2105-12.
- Regan JT, Rodgers M, Healy MG, Kirwan L, Fenton O. Determining phosphorus and sediment release rates from five Irish tillage soils. *Journal of Environmental Quality* 2010; 39: 1-8.
- Rodhe L, Pell M, Yamulki S. Nitrous oxide, methane and ammonia emissions following slurry spreading on grassland. *Soil Use and Management* 2006; 22: 229-237.
- Rogovska N, Fleming P, Laird D, Cruse R, Parkin T, Meek D. Impact of biochar on manure carbon stabilization and greenhouse gas emissions. *Soil Science Society of America Journal* 2011; 75: 871-879.
- Rose CW. *An introduction to the environmental physics of soil, water and watersheds.* Cambridge University Press, Cambridge, UK, 2004.
- Rose CW, Williams JR, Snader GC, D.A. B. A mathematical model of soil erosion and deposition processes. I. Theory for plane and land element. *Soil Science Society of America Journal* 1983; 147: 991-995.

- Ruane E, Murphy P, Clifford E, O'Reilly E, French P, Rodgers M. Treatment of dairy soiled water using a woodchip filter. CIGR 17th World Congress of the International Commission of Agricultural and Biosystems Engineering, Quebec City, Canada. 14th-17th June 2010, 2010.
- Ryan D. A slurry spreader to meet farming needs and enviromental concerns. Crops Research Centre, Oak Park, Carlow. End of project report, 2005.
- Ryan D, Holden N, Carton O, Fitzgerald D, Murphy F. Pathways for nutrient loss to water; slurry and fertiliser spreading Teagasc Report. Available at: <http://www.teagasc.ie/research/reports/crops/4924/eopr4924.pdf> verified 30th June 2011, 2008.
- Ryan M, Fanning A. Effects of fertiliser N and slurry on nitrate leaching 'lysimeter studies on 5 soils'. Irish Geography 1996; 29: 126-136.
- SI 610. European communities (Good agricultural practice for protection of waters) Regulations 2010. Statutory Instruments. SI No. 610 of 2010. Available at: <http://www.environ.ie/en/Legislation/Environment/Water/FileDownload,25133,en.pdf> verified 13th June 2011., 2010.
- SAS. SAS for windows. Version 9.1. SAS/STAT® User's Guide. Cary, NC. SAS Institute Inc., 2004.
- Schroeder PD, Radcliffe DE, Cabrera ML, Belew CD. Relationship between soil test phosphorus and phosphorus in runoff: effects of soil series variability. Journal of Environmental Quality 2004; 33: 1452-63.
- Schulte R, Fenton O, Lalor S, Melland AR, Richards KG, Wall D, et al. Nitrates action plan for agriculture: expectations for water quality Available at: <http://www.epa.ie/downloads/pubs/other/events/oe/water2010/3.%20Dr%20Rogier%20chulte.pdf>, 2010b, verified August 20th 2010.
- Schulte RPO, Melland AR, Fenton O, Herlihy M, Richards KG, Jordan P. Modeling soil phosphorus decline: Expectations of Water Frame Work Directive policies. Environmental Science & Policy 2010b; 13: 472-484.
- Schulte R, Richards KG, Daly K, Kurz I, McDonald EJ, Holden N. Agriculture, meteorology and water quality in Ireland: a regional evaluation of pressures and

- pathways of nutrient loss to water. *Biology and Environment Proceedings of the Royal Irish Academy* 2006; 106: 117-133.
- Sharpley AN. Assessing phosphorus bioavailability in agricultural soils and runoff. *Nutrient Cycling in Agroecosystems* 1993; 36: 259-272.
- Sharpley AN. Soil phosphorus dynamics: agronomic and environmental impacts. *Ecological Engineering* 1995; 5: 261-279.
- Sharpley AN. Soil mixing to decrease surface stratification of phosphorus in manured soils. *Journal of Environmental Quality* 2003; 32: 1375-1384.
- Sharpley AN, McDowell RW, Kleinman PJA. Phosphorus loss from land to water: integrating agricultural and environmental management. *Plant and Soil* 2001a; 237: 287-307.
- Sharpley AN, McDowell RW, Kleinman PJ. Amounts forms, and solubility of phosphorus in soils receiving manure. *Soil Science Society of America* 2004; 68:2048-2057.
- Sharpley AN, McDowell RW, Weld JL, Kleinman PJ. Assessing site vulnerability to phosphorus loss in an agricultural watershed. *Journal of Environmental Quality* 2001b; 30: 2026-2036.
- Sharpley AN, Rekolainen S. Phosphorus in agriculture and its environmental implications. Phosphorus loss from soil to water. (Eds Tunney H, Carton OT, Brookes PC, Johnston AE) In: *Proceedings of a workshop, Wexford, Irish Republic, 29-31 September 1995*. 1997 pp. 1-53.
- Sharpley AN, Sims JT, Lemunyon J, Stevens RJ, Parry R. Agricultural Phosphorus and Eutrophication. In: *Department of Agriculture ARS-149*, Available at: <http://www.ars.usda.gov/is/np/Phos&Eutro2/agphoseutro2ed.pdf>, verified 13th September 2011, 2003.
- Sharpley AN, Smith SJ, Jones OR, Berg WA, Coleman GA. The transport of bioavailable phosphorus in agricultural runoff. *Journal of Environmental Quality* 1992; 21: 30-35.
- Sharpley AN, Tunney H. Phosphorus research strategies to meet agricultural and environmental challenges of the 21st century. *Journal of Environmental Quality* 2000; 29: 176-181.

- Sherlock RR, Sommer SG, Khan RZ, Wood CW, Guertal EA, Freney JR, Dawson CO, Cameron KC. Ammonia, methane and nitrous oxide emissions from pig slurry applied to a pasture in New Zealand. *Journal of Environmental Quality* 2002; 3: 1491-1501.
- Shi Y, Parker DB, Cole NA, Auvermann BW, Mehlhorn JE. Surface amendments to minimise ammonia emissions from beef cattle feedlots. *American Society of Agricultural Engineers* 2001; 44: 677-682.
- Shipitalo MJ, Bonta JV, Dayton EA, Owens LB. Impact of grassed waterways and compost filter socks on the quality of surface runoff from corn fields. *Journal of Environmental Quality* 2010a; 39: 1009-1018.
- Shipitalo MJ, Faucette B, Bonta J, Owens LB. Use of sorbent-amended compost filter socks in grassed waterways to reduce nutrient losses in surface runoff. (Eds. Buda AR) In: ASA, CSSA, and SSSA 2010 International annual meetings. Symposium-Emerging technologies to remove phosphorus from surface and groundwater, Long Beach, CA, 2010b.
- Singh A, Smyth BM, Murphy JD. A biofuel strategy for Ireland with an emphasis on production of biomethane and minimization of land-take. *Renewable and Sustainable Energy Reviews* 2010a; 14: 277-288.
- Singh BP, Hatton BJ, Singh B, Cowie AL, Kathuria A. Influence of biochars on nitrous oxide emission and nitrogen leaching from two contrasting soils. *Journal of Environmental Quality* 2010b; 39: 1224-1235.
- Smith DR, Moore PA, Griffis CL, Daniel TC, Edwards DR, Boothe DL. Effects of alum and aluminium chloride on phosphorus runoff from swine manure. *Journal of Environmental Quality* 2001a; 30: 992-998.
- Smith DR, Owens PR, Leytem AB, Warnemuende EA. Nutrient losses from manure and fertilizer applications as impacted by time to first runoff event. *Environmental Pollution* 2007; 147: 131-137.
- Smith KA, Jackson DR, Misselbrook TH, Pain BF, Johnson RA. PA-Precision agriculture: Reduction of ammonia emission by slurry application techniques. *Journal of Agricultural Engineering Research* 2000; 77: 277-287.

- Smith KA, Jackson DR, Pepper TJ. Nutrient losses by surface run-off following the application of organic manures to arable land. 1. Nitrogen. *Environmental Pollution* 2001b; 112: 41-51.
- Smith KA, Jackson DR, Withers PJA. Nutrient losses by surface run-off following the application of organic manures to arable land. 2. Phosphorus. *Environmental Pollution* 2001c; 112: 53-60.
- Søgaard HT, Sommer SG, Hutchings NJ, Huijsmans JFM, Bussink DW, Nicholson F. Ammonia volatilization from field-applied animal slurry-the ALFAM model. *Atmospheric Environment* 2002; 36: 3309-3319.
- Sommer SG, Générmont S, Cellier P, Hutchings NJ, Olesen JE, Morvan T. Processes controlling ammonia emission from livestock slurry in the field. *European Journal of Agronomy* 2003; 19: 465-486.
- Sommer SG, Jensen LS, Clausen SB, Søgaard HT. Ammonia volatilization from surface-applied livestock slurry as affected by slurry composition and slurry infiltration depth. *Journal of Agricultural Science, Cambridge* 2006; 144: 229-235.
- Stark CH, Richards KG. The continuing challenge of agricultural nitrogen loss to the environment in the context of global change and advancing research. *Dynamic Soil, Dynamic Plant* 2008; 2: 1-12.
- Steiner C, Das KC, Melear N, Lakly D. Reducing nitrogen loss during poultry litter composting using biochar. *Journal of Environmental Quality* 2010; 39: 1236-1242.
- Steiner C, Glaser B, Geraldtes Teixeira W, Lehmann J, Blum WEH, Zech W. Nitrogen retention and plant uptake on a highly weathered central Amazonian Ferralsol amended with compost and charcoal. *Journal of Plant Nutrition and Soil Science* 2008; 171: 893-899.
- Stewart JWB, Sharpley AN. Controls on the dynamics of soil and fertilizer phosphorus and sulphur. (Eds. Follett RF). In: *Soil and organic matter as critical components of production systems*. 19. Soil Science Society of America and American Society of Agronomy, Madison, Wisconsin, SSSA, 1987, pp. 101-121.
- Stout WL, Sharpley AN, Pionke HB. Reducing soil phosphorus solubility with coal combustion by-products. *Journal of Environmental Quality* 1998; 17: 111-118.

- Streubel J, Collins H, Granatstein D, Krugerand C. Biochar Sorption of Phosphorus From Dairy Manure Lagoons. (Ed. Ippolito J) In: ASA, CSSA, and SSSA 2010 International annual meetings. Biochar effects on the environment and agricultural productivity: I, Long Beach, CA. Available at: <http://a-c-s.confex.com/crops/2010am/webprogram/Paper58223.html>, verified 22th September 2011, 2010.
- Sun G, Zhao Y, Allen S. Enhanced removal of organic matter and ammoniacal-nitrogen in a column experiment of tidal flow constructed wetland system. *Journal of Biotechnology* 2005; 115: 189-197.
- Sylvia DM, Fuhrmann JF, Hartel PG, Zuberer DA. Principles and applications of soil microbiology. Pearson Education Inc. New Jersey, 2005.
- Tabbara H. Phosphorus loss to runoff water twenty-four hours after application of liquid swine manure or fertilizer. *Journal of Environmental Quality* 2003; 32: 1044-1052.
- Tanner CC, Kloosterman VC. Guidelines for constructed wetland treatment of farm dairy wastewaters in New Zealand. NIWA Science and Technology Series No. 48. Hamilton, New Zealand. 1997.
- Tanner CC, Nguyen ML, Sukias JP. Constructed wetland attenuation of nitrogen exported in subsurface drainage from irrigated and rain-fed dairy pastures. *Water Science and Technology* 2005; 51: 55-61.
- Tchobanoglous G, Burton FL, Stensel HD. Wastewater engineering treatment and reuse. Forth edition. McGraw-Hill, Boston. 2003, pp 1848.
- Toet S, Van Logtestijn RSP, Schreijer M, Kampf R, Verhoeven JTA. The functioning of a wetland system used for polishing effluent from a sewage treatment plant. *Ecological Engineering* 2005; 25: 101-124.
- Torbert HA, Daniel TC, Lemunyon JL, Jones RM. Relationship of soil test phosphorus and sampling depth to runoff phosphorus in calcareous and noncalcareous soils. *Journal of Environmental Quality* 2002; 31: 1380-1387.
- Torbert HA, King KW, Harmel RD. Impact of soil amendments on reducing phosphorus losses from runoff in sod. *Journal of Environmental Quality* 2005; 34: 1415-1421.
- Tunney H. A Note on a balance sheet approach to estimating the phosphorus fertiliser Needs of Agriculture. *Irish Journal of Agricultural Research* 1990; 29: 149-154.

- Tunney H. Phosphorus needs of grassland soils and loss to water. (Eds. Steenvoorden J, Claesses F, Willems J.). In: International conference on agricultural effects on ground and surface waters. International association of hydrological sciences, Wageningen, Netherlands, 2000, pp. 63-69.
- United Nations. Kyoto protocol to the United Nations framework convention on climate change. Available at: <http://unfccc.int/resource/docs/convkp/kpeng.pdf>, verified 27th June 2011, 1998.
- USEPA. United States environmental protection agency. Office of water regulations and standards, DC 20460 1986. Available at: http://water.epa.gov/scitech/swguidance/standards/criteria/aqlife/upload/2009_01_13_criteria_goldbook.pdf, verified 12th April 2011, 1986.
- USEPA. United States Environmental Protection Agency. Office of water, science and technology. National recommended water quality criteria for priority pollutants. 2009. Available at: <http://water.epa.gov/scitech/swguidance/standards/current/index.cfm>. Verified 8th September 2011, 2009.
- Uusi-Kämpä J, Braskerud B, Jansson H, Syversen N, Uusitalo R. Buffer zones and constructed wetlands as filters for agricultural phosphorus. *Journal of Environmental Quality* 2000; 29:151-158.
- Uusi-Kämpä J, Turtola E, Närvänen A, Jauhiainen L, Uusitalo R. A preliminary study on buffer zones amended with P-binding compounds. (Eds. Turtola E, Ekholm P, Chardon W) In: Novel methods for reducing agricultural nutrient loading and eutrophication: Meeting of COST 869, 14-16 June, Jokioinen, Finland. Available at: http://www.cost869.alterra.nl/Finland/abs_Uusi.pdf, verified 8th September 2011, 2010; p. 19.
- Vaananen R, Nieminen M, Vuollekoski M, Ilvesniemi H. Retention of phosphorus in soil and vegetation of a buffer zone area during snowmelt peak flow in southern Finland. *Water, Air, and Soil Pollution* 2006; 177: 103-118.
- Van Zwieten L, Kimber S, Morris S, Chan K, Downie A, Rust J, Joseph S, Cowie A. Effects of biochar from slow pyrolysis of papermill waste on agronomic performance and soil fertility. *Plant and Soil* 2010; 327: 235-246.

- Velthof G, Kuikman P, Oenema O. Nitrous oxide emission from soils amended with crop residues. *Nutrient Cycling in Agroecosystems* 2002; 62: 249-261.
- Velthof G, Oenema O. Nitrous oxide emission from dairy farming systems in the Netherlands. *Netherlands Journal of Agricultural Science* 1997; 45: 347-360.
- Verhoeven JTA, Meuleman AFM. Wetlands for wastewater treatment: Opportunities and limitations. *Ecological Engineering* 1999; 12: 5-12.
- Vitousek PM, Naylor R, Crews T, David MB, Drinkwater LE, Holland E, Johnes PJ, Katzenberger J, Martinelli LA, Matson PA, Nziguheba G, Ojima D, Palm CA, Robertson GP, Sanchez PA, Townsend AR, Zhang FS. Nutrient imbalances in agricultural development. *Science* 2009; 324: 1519-1520.
- Wang JH, Yu TR. Release of hydroxyl ions during adsorption of chloride by variable charge soils. *Z. Pflanzenernähr Bodenkd* 1998; 161: 109-113.
- Wardle DA, Nilsson MC, Zackrisson O. Fire-derived charcoal cause's loss of forest humus. *Science* 2008; 320:629.
- Watts DB, Torbert HA. Impact of gypsum applied to grass buffer strips on reducing soluble P in surface water runoff. *Journal of Environmental Quality* 2009; 38: 1511-1517.
- Wild A. Russell's soil conditions and plant growth. Eleventh edition. Longman Group UK Limited Harlow, 1988.
- Williams JD, Wilkins DE, McCool DK, Baarstad LL, Klepper BL, Papendick RI. A new rainfall simulator for use in low-energy rainfall areas. *Applied Engineering in Agriculture* 1998; 14: 243-247.
- Winsley P. Biochar and bioenergy production for climate change mitigation. *New Zealand Science Review* 2007; 64: 5-10.
- Withers PJA, Bailey GA. Sediment and phosphorus transfer in overland flow from a maize field receiving manure. *Soil Use and Management* 2003; 19: 28-35.
- Withers PJA, Clay SD, Breeze VG. Phosphorus transfer in runoff following application of fertilizer, manure, and sewage sludge. *Journal of Environmental Quality* 2001; 30: 180-188.

- Wulf S, Maeting M, Clemens J. Application technique and slurry co-fermentation effects on ammonia, nitrous oxide, and methane emissions after spreading: I. Ammonia volatilization. Vol 31. Madison, WI: American Society of Agronomy, 2002a.
- Wulf S, Maeting M, Clemens J. Application technique and slurry co-fermentation effects on ammonia, nitrous oxide, and methane emissions after spreading: II. Greenhouse gas emissions. *Journal of Environmental Quality* 2002b; 31: 1795-1801.
- Yanai Y, Toyota K, Okazaki M. Effects of charcoal addition on N₂O emissions from soil resulting from rewetting air-dried soil in short-term laboratory experiments. *Soil Science and Plant Nutrition* 2007; 53: 181-188.
- Zhang GY, Dou Z, Toth JD, Ferguson J. Use of flyash as environmental and agronomic amendments. *Environmental Geochemistry and Health* 2004; 26: 129-134.

APPENDIX

Appendix A List of publications

JOURNAL PAPERS (Accepted)

Brennan RB, Fenton O, Rodgers M, Healy MG. 2011. Evaluation of chemical amendments to control phosphorus losses from dairy slurry. *Soil Use and Management* 27: 238-246.

Brennan RB, Fenton O, Grant J, Healy MG. 2011. Impact of chemical amendment of dairy cattle slurry on phosphorus, suspended sediment and metal loss to runoff from a grassland soil. *Science of the Total Environment* 409(23):5111-8.

MANUSCRIPTS IN PREPARATION

Brennan RB, Fenton O, Healy MG, Lanigan G. Effect of chemical amendment of dairy cattle slurry on greenhouse gas and ammonia emissions (Submitted: *Biological Engineering*)

Brennan RB, Fenton O, Grant J, Healy MG. Rainfall simulation study investigating the effect of chemical amendment of dairy cattle slurry on runoff characteristics and nutrient loss from grassland plots (Target journal: *Science of the Total Environment*).

Brennan RB, Fenton O, Grant J, Healy MG. The long term impact of adding chemically amended dairy slurry to WEP, soil test phosphorus and pH in five grassland soils (Submitted: *Journal of Environmental Quality*).

INTERNATIONAL CONFERENCE PAPERS

Brennan RB, Fenton O, Healy MG. 2010. Chemical amendment of dairy cattle slurry for control of phosphorus in runoff from grasslands. A05 symposium on emerging

technologies to remove phosphorus. ASA-CSA-SSSA International Meetings, Long Beach, CA. 31 October - 4 November, 2010 (*Oral presentation*).

Brennan RB, Fenton O, Healy MG. 2010. Evaluation of chemical amendments to control soluble phosphorus losses from dairy cattle slurry. (Eds. Turtola E, Ekholm P, Chardon W). In: MTT Science 10. Novel methods for reducing agricultural nutrient loading and eutrophication: Meeting of COST 869, 14-16 June, Jokioinen, Finland. p. 18 (*Oral presentation*).

NATIONAL CONFERENCE PAPERS

Brennan RB, Healy MG, Lanigan G, Fenton O. 2011. Chemical amendment of dairy cattle slurry for control of P in runoff from grasslands. Walsh Fellowship Seminars. 12 July, RDS, Co Dublin (*Poster presentation*).

Brennan RB, Fenton O, Grant J, Healy MG. 2011. Mitigating incidental DRP losses from land application of dairy cattle slurry using chemical amendments. Agricultural Research Forum Conference. 14-15 March, Tullamore, Co. Offaly (*Oral presentation*).

Brennan RB, Fenton O, Rodgers M, Healy MG. 2010. Chemical amendment of dairy cattle slurry for control of phosphorus in runoff from grasslands. SEGH 2010. 27 June - 2 July, 2010. National University of Ireland, Galway (*Oral presentation*).

Brennan RB, Fenton O, Rodgers M, Healy MG. 2010. The addition of chemical amendments to dairy cattle slurry for the control of phosphorus in runoff from grasslands. BSAS/WPSA/Agricultural Research Forum Conference. Queen's University, Belfast. 12-14 April, 2010 (*Oral presentation*).

Brennan RB, Fenton O, Rodgers M, Healy MG. 2010. Chemical amendment of dairy cattle slurry to reduce P loss from grasslands. 19th World Congress of Soil Science. Brisbane, Australia, 1-6 August, 2010 (*Poster presentation*).