



Provided by the author(s) and NUI Galway in accordance with publisher policies. Please cite the published version when available.

Title	Enabling Legacy PTP Cameras and Printers as Networked PTP/IP Appliances
Author(s)	Corcoran, Peter
Publication Date	2007-04-10
Publication Information	Bigioi, P., Raducan, I., Steinberg, E., & Corcoran, P. (2007). Enabling Legacy PTP Cameras and Printers as Networked PTP/IP Appliances. Paper presented at the Consumer Electronics, 2007. ICCE 2007. Digest of Technical Papers. International Conference on.
Publisher	IEEE
Link to publisher's version	http://ieeexplore.ieee.org/search/srchabstract.jsp?tp=&arnumber=4146055
Item record	http://hdl.handle.net/10379/1613

Downloaded 2023-03-23T11:19:01Z

Some rights reserved. For more information, please see the item record link above.



Enabling Legacy PTP Cameras and Printers as Networked PTP/IP Appliances

Petronel Bigioi, Illariu Raducan, Eran Steinberg, and Peter Corcoran, *Member, IEEE*

Abstract — PTP/IP is a new connectivity standard for networked imaging appliances which combines the ease of use and seamless connectivity of Picture Transfer Protocol (PTP) with the ubiquity of TCP/IP networks. In this paper we examine methods to allow legacy PTP appliances to gain the benefits of PTP/IP through the design of bridge and gateway adapters which can be simply plugged into the USB ports of such appliances. The internal firmware stacks of such adapters are described and practical case studies describe the adaption of legacy PTP cameras and printers to connect over a conventional 802.11 wireless LAN.

Keywords — Digital Cameras, Network Transport Protocols, Picture Transfer Protocol, Device Connectivity and Consumer Electronics.

I. INTRODUCTION

With the wide adoption of new wireless technologies it was clear that sooner or latter the digital still camera will become a networking device. A new transport protocol, PTP/IP was adopted as a CIPA standard in 2005 [3]. The new transport is described in detail in [4] and it enables PTP [1], which could previously only be used with USB device connections [2], to be used with TCP/IP networks. The PTP/IP standard allows extension to a network environment without affecting applications that use PTP. It also enables multiple simultaneous connections among digital imaging devices, which was not possible with PTP over USB.

With PTP [5-7], digital cameras can exchange images with host computers, printers, other imaging and display devices. The interoperability resulting from the widespread adoption of PTP over USB transport has greatly reduces consumers' frustration at the difficulty of transferring photos from camera to computer, printer, or kiosk, and contributed to the ongoing growth in sales of digital cameras and associated devices.

While PTP/IP enables next generation products to function over 802.11 home WLANs there remains a large installed base of legacy PTP appliances. With the advent of PTP/IP the users of such cameras and printers may feel unhappy that these recently purchased products are already obsolete and may be reluctant to pay the cost of upgrading to a new PTP/IP compatible printer or camera. In turn this may slow the adoption of PTP/IP in the market.

Bearing these factors in mind a decision was taken to

Petronel Bigioi is VP of Engineering at FotoNation (Ireland) Ltd.; e-mail: petronel@fotonation.com.

Illariu Raducan is a Senior Engineer at FotoNation (Ireland) Ltd.; e-mail: lale@fotonation.com.

Peter Corcoran is with the Faculty of Engineering at National University of Ireland, Galway; e-mail: peter.corcoran@nuigalway.ie.

Eran Steinberg is CEO of FotoNation Inc.; e-mail: erans@fotonation.com.

investigate the feasibility of creating low-cost USB adapters with 802.11 connectivity which could convert legacy cameras and printers into PTP/IP compatible appliances. This would allow existing users of PTP products a low-cost upgrade to convert these legacy appliances and gain the benefits of full device connectivity over a home WLAN. As generic low cost USB to WLAN adapters are available the key design problems relate to the additional adaption which is required to the internal firmware stacks of these adapters in order to support the additional signaling requirements of PTP/IP – in particular the requirements for *device discovery* and *device bonding* which are inherent in PTP/IP.

II. SYSTEM DESIGN

A number of alternative WLAN chipsets and SoC hardware platforms were investigated. Each of these had various pros and cons and a brief summary of our initial feasibility studies for several such platforms is given. It was found that hardware platforms where there is support for open source software tend to be easier to work with and key adaptations of the firmware to the underlying hardware tend to more easily achieved. Initial prototyping was achieved using a commodity wireless access point to which a full open-source operating system had been ported. This provided complete hardware level access to a mass market chipset for negligible set-up costs and was a key factor in completing the initial product feasibility studies.

Some firmware modifications were required in the adapter firmware over and above the normal adaption of a USB communications stack to provide TCP/IP network connectivity. These included:

A. Device Discovery Mechanism

A specialized PTP-IP discovery protocol was developed for this purpose and serves a similar role to that of other service and device discovery protocols: it helps to find devices and services in the networking environments. Its targeted scope, however, is limited to discovering imaging devices that support PTP-IP. This discovery protocol can be used instead of standard protocols like UPnP and Rendezvous when the complexity of the standard approaches is beyond the capabilities of many imaging appliances. The protocol is based on UDP broadcast mechanisms and can be used in conjunction with TCP/IP stacks that do not implement multicasting.

B. Device Bonding Mechanisms

Dynamic Bonding: this approach can be implemented on devices with more sophisticated user interfaces and it is built on the feature of PTP-IP protocol where the exchange of GUIDs between devices occurs during the PTP/IP connection establishment phase. The implementation of

PTP/IP in the Responder transport can pass the GUID information to the application level, allowing the device to ask the user for permission to connect. Similarly, on the *initiator*, a network camera setup application can allow the user to browse the network for *responders* and select one.

PTP-IP Pairing Protocol: this protocol has been developed specifically for PTP-IP devices that have no user interface. The only requirement is for those devices to have a way to enter a special *pairing state* for a short period of time (e.g. a simple button). The main idea is for the user to perform asynchronous action (e.g. button press) on both devices that are to establish a PTP-IP connection. At the end of the *pairing interval*, both devices should have detected exactly one peer device and a peer-to-peer bond is established.

III. PRACTICAL ADAPTER EMBODIMENTS

A. PTP Camera Adapter

This can be either an internal or an external PTP/USB to PTP/IP device that network enables an existing USB digital camera which supports the PTP protocol. When implemented externally, the adapter takes the form of a dongle which plugs into the USB port of the camera. The camera only runs PTP protocol over USB, while the PTP adapter acting as either a bridge or a gateway runs all the required communication protocols to make the camera behave correctly as a PTP-IP network camera. One end of the adapter acts as a USB-Initiator and is connected to the camera, and another end is a PTP/IP-Responder and is connected to a PTP/IP Initiator.

Where the camera implements a PictBridge™ client, then an adapter which can support a single PTP session is adequate and a simple PTP Bridge is implemented in the adapter firmware. The protocol for selecting the PTP device with which the camera communicates during this session is implemented within a device discovery layer which is responsive to a user actuating a pairing actuator (not shown) on the adapter and an associated printer within the required time out period and without interference from other pairing devices.

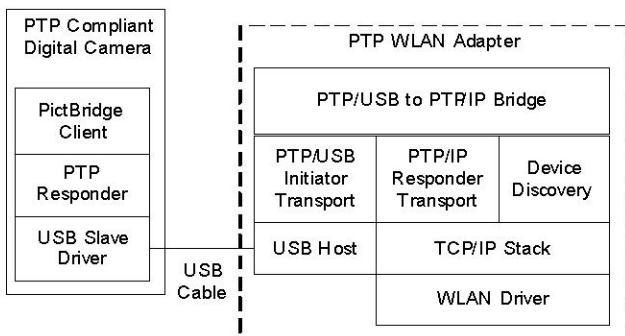

Fig 1: Protocol Stacks for PTP Camera Adapter

B. PTP Printer Adapter

An internal or external PTP/IP to PTP/USB device that network enables an existing USB PictBridge™ Printer. Again, when implemented externally, the adapter takes the form of a USB dongle. The printer runs PictBridge™ over

USB, while the PTP adapter running as a gateway runs all the required communication protocols to make the printer look like a network PictBridge™ printer. In this case one, end of the adapter is a USB-Responder and is connected to the printer, and another end is a PTP/IP-Initiator and is connected for example across a WLAN to a WiFi camera.

Such a translator allows a currently available standard PictBridge™ printer to talk with PTP/IP cameras that have recently become available on the market.

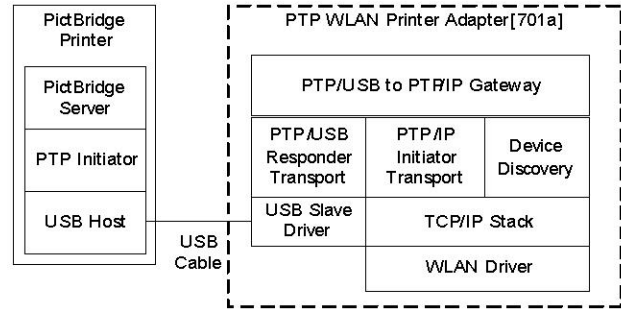

Fig 2: Protocol Stacks for PTP Printer Adapter

This printer adapter has two interfaces: a WIFI interface and a USB Slave interface. Its primary function is to transform a standard USB PictBridge™ printer into a WIFI PictBridge™ printer, available on a wireless local area network. Such an adapter preferably connects only to PictBridge™ clients (i.e. PTP/IP Responders that advertise their application protocol to be PictBridge™, in other words, their intent to print).

In practice the adapter can only be implemented with a gateway layer rather than with more basic bridge functionality. One reason is that the legacy printer side USB transport (unlike PTP/IP) does not carry enough self-descriptive information about the command being transported, so it does not allow the PTP Printer Adapter to be implemented as a simple PTP Bridge.

REFERENCES

- [1] ISO 15740, "Picture transfer protocol (PTP) for digital still photography devices", *Photography - Electronic still picture imaging*, 2005
- [2] USB Implementer's Forum, "Universal Serial BusStill Image Capture Device Definition Revision 1.0", http://www.usb.org/developers/devclass_docs/usb_still_img1_0.pdf, July 2000.
- [3] Camera & Imaging Products Association (CIPA), "PTP-IP Picture Transfer Protocol over IP version 1.0", Japan, 2005. <http://www.cipa.jp/hyoujunka/kikaku/pdf/DC-X005.pdf>.
- [4] P. Bigioi, G. Susanu, E. Steinberg, and P. Corcoran, "PTP/IP - a new transport specification for wireless photography", *Consumer Electronics, IEEE Transactions*, vol. 51, pp.240-244, Feb. 2005.
- [5] P. Bigioi, E. Steinberg, G. Susanu, and A. Pososion, "Picture Transfer Protocol - the answer to Digital Camera Connectivity", *Proc. of the 9th Intl. Conference on Optimization of Electrical and Electronic Equipments*, vol. 3, pp. 217 -226, May 2004.
- [6] P. Bigioi, G. Susanu, P. Corcoran, and I. Mocanu, "Digital camera connectivity solutions using the picture transfer protocol (PTP)", *Consumer Electronics, IEEE Transactions* vol. 48, Issue 3, pp. 417 - 427, Aug. 2002.
- [7] P. Bigioi, P. Corcoran, and G. Susanu, "Digital imaging services using PTP ", *Consumer Electronics, 2002. ICCE. 2002 Digest of Technical Papers*, pp. 54-55, June 2002.