



Provided by the author(s) and University of Galway in accordance with publisher policies. Please cite the published version when available.

Title	Lifecycle environmental and economic performance of nearly zero energy buildings (NZEB) in Ireland
Author(s)	Goggins, Jamie; Moran, Paul; Armstrong, Alan; Hajdukiewicz, Magdalena
Publication Date	2016-01-16
Publication Information	Goggins, Jamie, Moran, Paul, Armstrong, Alan, & Hajdukiewicz, Magdalena. (2016). Lifecycle environmental and economic performance of nearly zero energy buildings (NZEB) in Ireland. <i>Energy and Buildings</i> , 116, 622-637. doi: <a href="https://doi.org/10.1016/j.enbuild.2016.01.016">https://doi.org/10.1016/j.enbuild.2016.01.016</a>
Publisher	Elsevier
Link to publisher's version	<a href="https://doi.org/10.1016/j.enbuild.2016.01.016">https://doi.org/10.1016/j.enbuild.2016.01.016</a>
Item record	<a href="http://hdl.handle.net/10379/15115">http://hdl.handle.net/10379/15115</a>
DOI	<a href="http://dx.doi.org/10.1016/j.enbuild.2016.01.016">http://dx.doi.org/10.1016/j.enbuild.2016.01.016</a>

Downloaded 2024-05-23T02:13:12Z

Some rights reserved. For more information, please see the item record link above.



## **Lifecycle environmental and economic performance of Nearly Zero Energy Buildings (NZEB) in Ireland**

<sup>1, 2, 3, 4</sup>Jamie Goggins\*, <sup>1, 2, 3</sup>Paul Moran, <sup>1, 2</sup>Alan Armstrong, <sup>1, 2, 3</sup>Magdalena Hajdukiewicz

<sup>1</sup>College of Engineering & Informatics, National University of Ireland, Galway, Ireland.

<sup>2</sup>Ryan Institute for Environmental, Marine and Energy Research, National University of Ireland, Galway, Ireland.

<sup>3</sup>Informatics Research Unit for Sustainable Engineering (IRUSE), Department of Civil Engineering, National University of Ireland, Galway, Ireland

<sup>4</sup> Marine Renewable Energy Ireland (MaREI) Research Centre, Galway, Ireland

\* [Jamie.Goggins@nuigalway.ie](mailto:Jamie.Goggins@nuigalway.ie); +35391492609.

### **Abstract**

Directives in the European Union are ensuring that buildings in this region are moving towards nearly zero energy buildings (NZEB). For countries like Ireland, which has a temperate oceanic climate, a key to achieving NZEB is to have high thermal and air tightness performances of the building envelope. Consequently, as the operational energy of the building reduces, the embodied energy (and embodied global warming potential) typically increases as a proportion of the lifecycle energy of the building due to increased embodied energy of the building envelope and the lower operational energy.

In order to assess if a design strategy is in fact sustainable, it is becoming essential to evaluate environmental and economic LCA of building design strategies. This paper presents the outcomes of a number of case study buildings in Ireland, which focuses on the full environmental and economic lifecycle assessment of buildings to assess the impact changes in building regulations are having on the contribution of both the construction and operation of a building's lifecycle as they move towards NZEB standards.

If designed with a focus on achieving a high thermal and air tightness, a building with an embodied energy intensity less than a building that achieves compliance with 2011 Irish building energy performance regulations can achieve a NZEB standard.

**Topics:** Nearly zero energy buildings, Life-cycle energy, Life cycle global warming potential gas emissions, Life cycle cost, Embodied energy, Embodied global warming potential, Energy performance, Renewable Energy

## **1 General Introduction**

People spend approximately 90% of their lives indoors [1]. Thus, it is very important to maintain safe, healthy and comfortable conditions in buildings – our living and working environments. However, in order to maintain these conditions in buildings, a substantial portion of the world's energy consumption is required. Approximately 40% of the world's energy consumption and nearly a third of greenhouse gas (GHG) emissions are associated with the building sector [2].

As a consequence, the European Commission introduced the Energy Performance Building Directive (EPBD) 2002/91/EC [3] targeted at widespread reduction in building operational energy consumption and GHG emissions in EU member states. This was superseded in 2013 [4] and a significant objective of EPBD 2010/31/EU (recast) [4] is the mandatory introduction in all member states of NZEB for all new buildings or those receiving significant retrofit from 2020 (from 2018 for public buildings). A NZEB is a building that has a very high energy performance. The nearly zero or very low amount of energy required should be covered to a very significant extent by energy from renewable sources, including those produced on-site or nearby. This legislation will help EU member states achieve their short and long term energy and GHG reduction goals [5,6].

There is a great deal of research available in literature on reducing the impact of the energy associated with the operational stage of a building's lifecycle. To achieve lower operational energy, in many instances the solutions involve additional material in constructing the building. However, with the impact of operational energy (OE) of buildings reducing over their life span, more attention is being paid to the energy related to the production of the materials used to create and maintain the buildings. Thus, environmental assessments of a building's lifecycle are becoming the standard method for determining the sustainability of a building.

### **1.1 Moving towards NZEBs in Ireland**

Various national construction industry environmental themed regulations and targets [7–10], addressing energy usage and GHG emissions, have been introduced in Ireland. These aim to limit climate change affects for future generations and help society achieve “sustainable development” [11,12]. The minimum energy performance standards for residential buildings in Ireland set out in Irish Building Regulations have improved from the 2005 Regulations [13] to the 2011 Regulations [14] by 60% in terms of primary energy usage, as determined using the Dwelling Energy Assessment Procedure (DEAP) software tool [15] (Table 1). The DEAP software tool is used to produce Building Energy Rating (BER) labels, which rate the energy performance of buildings.

The BER assessment system was established due to the requirements of EPBD 2002 [3]. A BER rates the energy performance of buildings on a simple scale of A1 to G. It is based on the characteristics of the building and is not dependent on the behaviour of the occupants [16]. An A1 rated dwelling equates to the most operational energy efficient building. The primary energy consumption in a building of A1 and G ratings are 25 kWh/m<sup>2</sup>/year (i.e. 90 MJ/m<sup>2</sup>/year) and 450 kWh/m<sup>2</sup>/year (i.e. 1620 MJ/m<sup>2</sup>/year), respectively. Thus, the primary energy consumption of an

A1 is approximately 5% of that of a G-rated building. As of December 2013, one in eight homes in Ireland were rated at F/G with only 0.6% achieving an A-rated status [10]. Given the above along with the fact that thermal performance standards were not introduced until the Building Regulations of 1979 [13] and 44% of houses occupied were built before 1980 according to the most recent census, it can be seen why the Irish housing stock is among the poorest in Europe in terms of energy efficiency [10].

A cost optimum analysis conducted by the Department of the Environment, Heritage and Local Government in Ireland [17] suggested that revised building regulations in Ireland would set the maximum primary energy usage requirement of new residential buildings to be reduced by a further 25% from the 2011 regulations to meet NZEB conditions (Table 1).

**Table 1:** Timeline showing requirements of new dwellings built to Irish Building Regulations and conforming to BER grades based on DEAP and legislation

Timeline		Building Regulations			
		2005	2008	2011	2016-2020
PART L (Dwellings)	% Improvement	Baseline	40% and renewable	60%	NZEB
DEAP	Primary Energy (Average Dwelling) MJ/m <sup>2</sup> /annum	540	324	216	162
	CO <sub>2</sub> (Average Dwelling) kg/m <sup>2</sup> /annum	30	18	12	10
EPBD	BER (Average Dwelling)	B3	B1	A3	A2

## 1.2 Objectives

This paper presents environmental and economic lifecycle assessments (LCA) of typical two-storey semi-detached residential buildings in Ireland, using primary energy usage, global warming potential and economic costs as indicators. The aim of the paper is to highlight the impact changes in building regulations are having on the contribution of both the construction and operation of a

building's lifecycle as they move towards NZEB standards. The importance of developing a design strategy that mitigates both the embodied and operational energy impact of a buildings lifecycle is also discussed.

## **2 Published environmental LCA studies**

Upon establishment of NZEBs in the residential market, increased attention should be placed on the environmental impact of installed building materials. Therefore, carrying out environmental and economic LCA analysis on residential buildings in Ireland, constructed to various energy performance criteria, will aid designers to adapt a sustainable holistic lifecycle approach for domestic construction projects going forward.

Hence, it is important to assess previous environmental LCA studies conducted on residential buildings in order to gain a perspective on typical buildings' relative embodied energy (EE), OE, embodied global warming potential (EC) (also known as embodied carbon) or operational global warming potential (OC) (also known as operational carbon) intensity values. Global warming potential (GWP) is a relative measure of how much heat a GHG traps in the atmosphere. Through assessment of these studies, the real importance of the LCA approach in construction can be highlighted.

### **2.1 Lifecycle energy breakdown**

Table 2 summarises a broad range of published environmental LCA studies of residential buildings, in terms of the proportional breakdown of lifecycle energy attributed to OE and EE per square metre of the functional unit floor area used in their respective studies, system boundary utilised, location and climatic conditions of region [18–32]. All referenced papers in Table 2 use a process based LCA methodology.

The climatic regions are divided into five climate zones (A to E) with buildings in Zone A typically requiring high cooling and low heating needs and buildings in Zone E typically requiring low cooling and high heating needs. The criteria for each zone is based on the amount of heating degree days (HDD) and cooling degree days (CDD) experienced at the location [33]. HDD and CDD are a measure of how much (°Celsius) and for how long (days) outside air temperature was lower and higher than the base temperature. Using information gathered from an online degree day database [34] and taking 18°C as the base temperature for all climate types, climate zones were assigned to each of the case study locations.

Significant variations in proportional lifecycle energy breakdown exist in the literature examined, from a lifecycle system boundary, lifespan, building type, structure type, location and material database perspective. Thus, a case study comparison is difficult. The contribution of EE to overall energy consumption in the wide range of 5 to 100% is shown in Table 2.

The OE in Table 2 accounts for the HVAC, hot water, lighting, appliance usage etc. depending on the individual study. The energy with regards to the maintenance, repair, replacement and refurbishment of materials during the operational phase is not included in the values given in Table 2. Buildings designed to latest building regulations or passive house standards generally have a lower OE contribution to their lifecycle energy. Two notable exceptions were found in buildings constructed in Norway [24] and Sweden [26]. The minimum energy requirement of residential buildings constructed to 2010 Norwegian Building Standards was 120 + 1600/m<sup>2</sup> of heated floor area kWh/m<sup>2</sup>/year [35]. This was more than 2007 Irish Building Regulations standards [36] (Table 1) and would only achieve a BER rating of B2 in Ireland. The OE of the residential building constructed in Sweden was based on the results of the OE of two passive buildings monitored for

a year [37]. The measured OE of the houses was found to be 27.5% to 32.4% higher than estimated due to the behaviour of the inhabitants.

Of the other reviewed papers (Table 2 and Table 3), only two monitored the OE of their case study building for a year [25,31]. The Italian passive house is a net-energy exporter residence which underestimated its energy consumption by 14.4% [25]. The estimated energy consumption is not reported in Ref.[31]. All other reviewed papers used simulation packages in order to calculate the OE of their respective case studies.

The contribution of EE to the overall energy consumption can be as low as 0% according to a case study on hypothetical building models in Finland [32]. In this study, 90% of the materials are assumed to be recycled at the end of the case study buildings life cycle and used for a secondary application. The results show that for light weight timber and cross laminated buildings, more energy is saved in the recycling of materials and their secondary application than is initially invested into the buildings. Therefore only the cradle to grave results are considered in this paper.

The most common climatic zone of the reviewed papers in Table 2 is Zone E which is the climatic zone Ireland falls within. Based on a 60 year lifespan for a residential building (which is taken as standard in Ireland) for the case studies in Zone E and assuming a linear relationship between a building's lifespan to determine its overall OE lifecycle energy contribution, an average EE contribution of 21% was calculated for the published studies. Note that reoccurring energy and system boundary differences were not considered here.

**Table 2:** Environmental LCA residential building studies with OE and EE proportions

Source	Building Type	Construction Type	Location	Climatic Zone	Year of Construction	Area (m <sup>2</sup> )	Lifespan (years)	Life Cycle Boundary	Percentage of OE (%)	Percentage of EE (%)
--------	---------------	-------------------	----------	---------------	----------------------	------------------------	------------------	---------------------	----------------------	----------------------

Please cite: Goggins, J., Moran, P., Armstrong, A., Hajdukiewicz, M. (2016) 'Life cycle environmental and economic performance of Nearly Zero Energy Buildings (NZEB) in Ireland'. *Energy and Buildings* (in press). DOI 10.1016/j.enbuild.2016.01.016



[18]	Prefabricated single family units	Wood	Sweden	Zone E	1991/1992	130	50	Cradle-to-grave	83	17	
						129			85	15	
						138			85	15	
[19]*	Low energy mid-terrace house	Super-insulation experimental building	Timber	Norway	Zone E	1999	110	50	Cradle-to-grave	72	28
		Current Building Regulations with solar collectors							90	10	
		Current Building Regulations with exhaust air heat pump							92	8	
		Previous Building Regulations							95	5	
		Architect 'green' building regulations							92	8	
[20]	Passive Apartment	Original EE	Timber	Sweden	Zone E	2001	120	50	Cradle-to-cradle	57-60	40-43
		Minimum EE								69-73	27-31
		Maximum EE								56-61	39-44
[21]	3-storey Apartment Block	Prior to EPBD	Concrete	Northern Italy	Zone B		1,050	50	Cradle-to-gate	86	14
		Current EPBD Standards								81	19
		Borge Solare Standard								53	47
[22]	BIAC Standard House	Light Timber	New Zealand	Zone C		94	100	Cradle-to-site	74	26	
		Concrete							71	29	
		Super-insulated Timber							57	43	
[23]	Terraced House	Concrete	Spain	Zone B		222	50	Cradle-to-gate	69	31	
[24]*	Single family house	2010 Building Regulations	Wood	Norway	Zone E	Unknown	187	50	Cradle-to-grave	85-89	11-15
		Passive Regulations				Unknown	187	50	Cradle-to-grave	78-83	17-22

Please cite: Goggins, J., Moran, P., Armstrong, A., Hajdukiewicz, M. (2016) 'Life cycle environmental and economic performance of Nearly Zero Energy Buildings (NZEB) in Ireland'. *Energy and Buildings* (in press). DOI 10.1016/j.enbuild.2016.01.016

[25]	Passive House	Concrete/ Steel/Timber	Italy	Zone B	Unknown	251.6	70	Cradle-to- cradle	0	100
[26]**	Passive House	Timber	Sweden	Zone E	2010	160	50	Cradle-to- gate	81	19
[27]	Passive House	Solid	Austria	Zone D	Unknown	1,351	50	Cradle-to- grave	77	23
	Low energy house	Timber				1,341			77	23
	Low energy house	Timber				1,094			73	27
	Low energy house	Solid				901			72	28
	Low energy house	Solid				683			75	25
[28]	Single Family House	Light Timber	New Jersey, USA	Zone B	Unknown	255	65	Cradle-to- grave	79	21
	Single Family House	Concrete	Switzerla nd	Zone E	Unknown	191	65	Cradle-to- grave	49	51
[29]	2 bedroom apartment	Concrete	Portugal	Zone A	1940's	367	75	Cradle-to- site	80	20
	3 bedroom apartment					472			80	20
	5 bedroom apartment					1041			73	27
[30]	Detached house	Concrete	Italy	Zone B	Unknown	443	50	Cradle-to- grave	77	23
	Multi-dwelling Office					1827			79	21
						3353			85	15
[31]	Apartment Building	Concrete	Italy	Zone B	Unknown	610	70	Cradle-to- cradle	26	74
[32]	Detached house	Light weight timber	Finland	Zone E	Unknown	96	50	Cradle-to- grave	85	15
		Cross laminated timber							77	23
		Concrete							67	33
		Steel							72	28
	Row house	Light weight timber	Finland	Zone E	Unknown	316	50	Cradle-to- grave	85	15
		Cross laminated timber							76	24
		Concrete							69	31
		Steel							72	28
	Town house	Light weight timber	Finland	Zone E	Unknown	475	50	Cradle-to- grave	84	16
		Cross laminated timber							74	26
		Concrete							68	32

Please cite: Goggins, J., Moran, P., Armstrong, A., Hajdukiewicz, M. (2016) 'Life cycle environmental and economic performance of Nearly Zero Energy Buildings (NZEB) in Ireland'. *Energy and Buildings* (in press). DOI 10.1016/j.enbuild.2016.01.016

	Steel						72	28	
Apartment block	Light weight timber	Finland	Zone E	Unknown	1775	50	Cradle-to-cradle	83	17
	Cross laminated timber						73	27	
	Concrete						67	33	
	Steel						70	30	

\*Values estimated from graphs provided in paper, \*\*Total primary energy, non-renewable energy

## 2.2 Embodied energy and global warming potential values calculated building intensities

Table 3 summarises a broad range of published environmental LCA studies, in terms of EE and EC per square metre of the functional unit floor area used in their respective studies [18–25,27–32,38–46]. The number of LCA studies on buildings has increased in recent years due to growing popularity and significance of LCA, EE and EC. Eighteen from the selected studies were conducted in the preceding six years demonstrating the gradual growth in popularity. Consequently, aspects of environmental LCA has filtered into governmental policy signifying its national importance in Ireland [9]. All referenced papers in Table 3 used a process based LCA methodology apart from Ref. [44] which used a hybrid based methodology.

Studies conducted in climate zone E gave EE intensities ranging from 1731 to 23342 MJ/m<sup>2</sup> [18–20,24,28,32,38,42,46]. The large differences in results were related to the system boundaries of the studies, the types and standards that each of the buildings were constructed to. The average EE intensities of the buildings evaluated in Zone E is 4494 MJ/m<sup>2</sup>. System boundary, building construction type and standard differences were not considered for this average.

Studies conducted in countries gave EE intensities ranging from 3015 to 7559 MJ/m<sup>2</sup> [18,20,24]. The large differences in results were related to the system boundaries of the studies and the building standards that each of the buildings were constructed to. If the system boundary for the

houses constructed to a passive standard was taken as cradle-to-grave, the EE intensity range was 6086 to 7559 MJ/m<sup>2</sup>. Single prefabricated timber homes constructed in 1991 had an EE intensity between 4320 to 5040 MJ/m<sup>2</sup> [18].

Terraced, semi-detached and detached houses constructed in the United Kingdom (UK) showed a similar EE intensity (4900 to 5600 MJ/m<sup>2</sup>) [42] to the prefabricated timber homes constructed in Sweden [18]. A separate study of terraced, semi-detached and detached UK houses had an EE intensity ranging from 351 to 352 MJ/m<sup>2</sup> [46]. This was significantly less than values reported by all other studies. These results were considered to be incorrect based on the list of materials used to construct the houses and were not considered for further comparisons in this paper.

Local building construction methods, functional units and building design requirements can have a big impact on the EE intensities of single residential studies [25,28,30]. The EE intensity difference between a single family house constructed in New Jersey, USA compared to a house constructed in Switzerland was 10,908 MJ/m<sup>2</sup> [28]. The functional units of these studies were based on the heated floor area of each building. However, if the gross floor area of both houses were taken as the functional unit, the difference in EE intensities between the two buildings would only be 979 MJ/m<sup>2</sup>. The EE intensities of both buildings were large due to the superstructures of the buildings. Each building had a garage/basement which increased the amount of concrete required for the buildings superstructure. The Switzerland house was constructed to a higher energy standard meaning that more energy was required for the building envelope materials.

A detached family house in Italy also had high EE intensity values due to the superstructure [30]. The three storey concrete vertical envelope had the highest contribution to the assessed impact

categories. A passive house constructed in Italy had an EE intensity of 13,869 MJ/m<sup>2</sup> [25]. However, this house was a net energy exporter as it produced more energy on-site than importing from external sources.

This very large EE intensity was due to a number of factors. The impact of the superstructure of the building had a significant impact as the residence is constructed in a seismic area. The amount of concrete and cement generally used for a typical dwelling increases by 20% for protection against earthquakes [25]. The basement was the largest contributor of the building components to the EE. However, the floor area of the basement was not included in the functional unit of the study (1 m<sup>2</sup> of liveable floor area for a period of one year). The western façade of the building was covered in aluminium as protection for the building. Aluminium is a very energy intensive material with a primary energy intensity of 218 MJ/kg [47]. This highlights the importance of a designer's role in sustainability by selecting appropriate 'green' materials. This was also stressed by a case study where the same OE could have been achieved by a house of EE intensity ranging from 3015 MJ/m<sup>2</sup> to 4810 MJ/m<sup>2</sup> [20].

Therefore, it is important to evaluate different design strategies of a building. This allows for assessing the impact various strategies of a building's design have on the EE and OE. Of the reviewed studies (Table 3), only four other papers compared different design strategies of the same building [21,24,32,38].

Four different superstructure designs (light weight timber, cross laminated timber, concrete and steel) of four building types (detached house, row house, town house, apartment block) were evaluated in hypothetical building models in Finland [32]. The results show that buildings

constructed to have steel superstructures to be the optimum designs in terms of life cycle energy. However, only one indicator (energy) was evaluated in this study

A case study of a 3-story apartment block showed that an increase in EE investment from 4007 MJ/m<sup>2</sup> to 4158 MJ/m<sup>2</sup> reduced the OE of the life cycle energy consumption from 87% to 16%. This was primarily due to the installation of a geothermal heat pump [21]. Thus, the EE investment was paid back in 0.4 years. A New Zealand case study showed that investing 616 MJ/m<sup>2</sup> to convert from a light timber construction house to a super-insulated timber construction reduced the OE proportion of the buildings lifecycle from 74% to 57%, with the same heating system utilised in both analysis [22]. Thus, the EE investment was paid back in 10.4 years through the OE reduction.

Another case study showed that to change from the Norwegian 2010 Building Regulations to a Passive Building Standard for four different heating scenarios required an investment of 943 MJ/m<sup>2</sup> to 1259 MJ/m<sup>2</sup> [24]. These values were estimated from a graph and, as such, pay back times were not determined.

**Table 3:** EE and EC intensities of published residential environmental LCA

Source	Building Type	Construction Type	Location	Climate Zone	Year of Construction	Area (m <sup>2</sup> )	Lifespan (years)	Life Cycle Boundary	EE (MJ/m <sup>2</sup> )	EC (kgCO <sub>2e</sub> /m <sup>2</sup> )	
[18]	Prefabricated single detached units	Wood	Sweden	Zone E	1991	130	50	Cradle-to-grave	5,220	-	
						129			4,932	-	
						138			4,176	-	
[19]*	Low energy mid-terrace house	Super-insulation experimental building	Timber	Norway	Zone E	1999	110	50	Cradle-to-grave	4,424	-
										Current Building Regulations with solar collectors	2,470

Please cite: Goggins, J., Moran, P., Armstrong, A., Hajdukiewicz, M. (2016) 'Life cycle environmental and economic performance of Nearly Zero Energy Buildings (NZEB) in Ireland'. *Energy and Buildings* (in press). DOI 10.1016/j.enbuild.2016.01.016

		Current Building Regulations with exhaust air heat pump							2,005	-	
		Previous Building Regulations							1,800	5	
		Architect 'green' building regulations							2,470	8	
[21]	3-storey Apartment Block	Prior to EPBD	Concrete	Northern Italy	Zone B	1,050	50	Cradle-to-gate	4,007	-	
		Current EPBD Standards							4,158	-	
		Borge Solar Standard							4,428	-	
[20]	Passive Timber House	Terraced	Original EE	Sweden	Zone E	2001	120	50	Cradle-to-cradle	4,383-4,736	-
			Minimum EE						3,015-3,461	-	
			Maximum EE						4,266-4,810	-	
[22]	BIAC Standard Single Storey House	Single	Light Timber	New Zealand	Zone C	94	100	Cradle-to-site	4,425	-	
			Concrete						4,764	-	
			Super-insulated Timber						5,041	-	
[42]	Apartment (3-storey)		Concrete	UK	Zone E	2006	50	60	Cradle-to-site	6,600	480
	Apartment (4-storey)						50		6,300	460	
	Terraced						68		4,900	370	
	Semi-detached						73		5,600	425	
	Bungalow						76		8,200	620	
	Detached						125		5,500	410	
[38]	Semi-detached		Light Timber	Southern UK	Zone E	2008	65	100	Cradle-to-site	-	493
			Medium Concrete						-	512	
			Medium-heavy Concrete						-	539	
			Heavy Concrete						-	567	
[43]	Semi-detached		Concrete	Ireland	Zone E		105	60	Cradle-to-site	-	369
	Apartment						75		-	299	

Please cite: Goggins, J., Moran, P., Armstrong, A., Hajdukiewicz, M. (2016) 'Life cycle environmental and economic performance of Nearly Zero Energy Buildings (NZEB) in Ireland'. *Energy and Buildings* (in press). DOI 10.1016/j.enbuild.2016.01.016

[39]	Singe-landed house	Clay & Bricks Concrete	Indonesia	Zone A	1984	55	40	Cradle-to-site	837	-
									818	-
[40]	Passive House	Adobe	India	Zone A	2009	94	50	Unknown	2,299	1,000
[23]	Terraced House	Concrete	Spain	Zone B	2009	222	50	Cradle-to-gate	5,687	529
[41]	Various	Various	Worldwide	Various	2010	Various	Various	Various	3,600-8,760	-
[45]	Semi-detached	-	UK	Zone E	2010	100	-	Unknown	-	550
[44]	Residential Area	Concrete	Finland	Zone E	2011	70,000	25	Cradle-to-grave	-	3,200
[24]*	Two-storey single family house	Timber 2010 Regulations	Norway	Zone E	Unknown	187	50	Cradle-to-grave	6,608-7,238	387-414
		Timber Passive Regulations							7,552-8,181	441-468
[25]	Passive House	Concrete/ Steel/Timber	Italy	Zone B	Unknown	251.6	70	Cradle-to-cradle	13,869	1009
[27]	Residential building	Solid Passive	Austria	Zone D	Unknown	1351	50	Cradle-to-grave	11,864	794
		Timber low energy				1341			14,624	595
		Timber low energy				1094			16,414	840
		Solid low energy				901			15,267	982
		Solid low energy				683			15,068	943
[46]	Detached	Concrete	UK	Zone E	Unknown	130	50	Cradle-to-cradle	352	261
	Semi-Detached					90			351	283
	Terraced					60			352	280
[28]	Single Family House	Light Timber	New Jersey, USA	Zone B	Unknown	255	65	Cradle-to-grave	12434	583
	Single Family House	Concrete	Switzerl and	Zone E	Unknown	191	65	Cradle-to-grave	23342	1107
[29]	2 bedroom apartment	Concrete	Portugal	Zone A	1940's	367	75	Cradle-to-site	4176	272
	3 bedroom apartment					472			4082	262
	5 bedroom apartment					1041			3746	239
[30]	Detached house	Concrete	Italy	Zone B	Unknown	443	50	Cradle-to-grave	12955	1050
	Multi-dwelling					1827			8668	674
	Office					3353			7349	575

Please cite: Goggins, J., Moran, P., Armstrong, A., Hajdukiewicz, M. (2016) 'Life cycle environmental and economic performance of Nearly Zero Energy Buildings (NZEB) in Ireland'. *Energy and Buildings* (in press). DOI 10.1016/j.enbuild.2016.01.016



[31]	Apartment Building	Concrete	Italy	Zone B	Unknown	610	70	Cradle-to-cradle	27440	-
[32]	Detached house	Light weight timber	Finland	Zone E	Unknown	96	50	Cradle-to-grave	3356	-
		Cross laminated timber							5657	-
		Concrete							4857	-
		Steel							3830	-
	Row house	Light weight timber	Finland	Zone E	Unknown	316	50	Cradle-to-grave	2634	-
		Cross laminated timber							4586	-
		Concrete							3498	-
		Steel							3015	-
	Town house	Light weight timber	Finland	Zone E	Unknown	475	50	Cradle-to-grave	2423	-
		Cross laminated timber							4496	-
		Concrete							3156	-
		Steel							2754	-
	Apartment block	Light weight timber	Finland	Zone E	Unknown	1775	50	Cradle-to-grave	2112	-
		Cross laminated timber							3749	-
		Concrete							2434	-
		Steel							2328	-

\*Values estimated from graphs provided in paper

The only appropriate case study found in the literature of a semi-detached dwelling in Ireland [43] calculated a slightly lower EC than similar studies in the UK [38,42,45]. The difference might have been due to slight variations in production methodologies of certain building materials or minor differences in building code regulations [9,48].

Thus, a notable gap in the literature is identified. With significant construction of residential buildings in Ireland in the preceding decade [49], a sample of residential building quantification, in terms of lifecycle energy and global warming potential (GWP), is highlighted as a priority. Standardised comprehensive environmental LCA examining the lifecycle breakdown is required, and calculation of more accurate EE or EC intensity values for an Irish context is necessary. Thus, comparisons with previous international residential lifecycle energy and GWP values can be appropriately carried out.

### 3 Methodology

Utilising a standardised comprehensive LCA approach [50,51], environmental and economic LCA is conducted on various building designs, stressing the impact of different design strategies over an entire building's lifecycle. In this paper, case study residential dwellings in Ireland are designed in accordance with past, existing and future building energy performance regulations in Ireland, as outlined in Table 1 and Table 4, and assessed using a LCA diagnostic tool [52]. The functional units of MJ/m<sup>2</sup> and kgCO<sub>2e</sub>/m<sup>2</sup> of heated floor area are utilised for lifecycle energy consumption and GWP. The life cycle stages evaluated are expressed according to the modularity principle of a building life cycle [53].

**Table 4:** Maximum U-values specified in Irish Building Regulations [13,14,36]

Building Elements		2005 Building Regulations	2007 Building Regulations	2011 Building Regulations
U Value (W/m <sup>2</sup> K)				
Roofs	Pitched Insulation on Ceiling	0.16	0.16	0.16
	Roof Insulation on Slope	0.2	0.16	0.16
	Flat Roof	0.22	0.22	0.2
Walls		0.27	0.27	0.21
Ground Floors		0.25	0.25	0.21
External Doors, Windows and Rooflights		2.2	2	1.6

### 3.1 Material Production Stage (Module A1-A3)

Primary energy consumption and GWP impact during the material production stage of all materials/components (excluding appliances, fixtures and fittings) in the construction of the case study buildings are assessed using the Inventory for Carbon and Energy (ICE) V.2.0 [47]. This stage is also known as a cradle to gate system boundary.

EE and EC are values which represent the energy consumed by, and emissions caused by extracting, processing and manufacturing of materials. These calculations can be expressed mathematically as:

$$EE = \sum_1^n V_i \rho_i E_i \quad (1)$$

$$EC = \sum_1^n V_i \rho_i C_i \quad (2)$$

where  $V_i$  ( $m^3$ ) is volume,  $\rho_i$  ( $kg/m^3$ ) is density,  $E_i$  (MJ/kg) is EE intensity and  $C_i$  ( $kgCO_{2e}/kg$ ) is EC intensity of material  $i$ .

Spon Construction Price Book [54] is utilised for the economic evaluation of the net construction costs (NCC) of the components in the case study buildings. The NCC accounts for the labour, plant and material economic costs of the components in the case study buildings. Economic construction costs are updated to current values using relevant consumer price indices [55] and do not include Value Added Tax (VAT). If EE, EC and economic construction values are unobtainable from the ICE database [47] and Spons Construction Price Book [54], data is sourced from other available databases and literature, as noted in the relevant sections of the paper.

### 3.2 Use Stage: Building Operation (Module B6)

Operational primary energy, GWP and economic cost of the case study buildings are estimated using DEAP [15], together with current energy prices [56,57]. A life cycle of 60 years is taken as

the life span of a residential building in Ireland. OE and OC are values which represent the primary energy consumed and GWP emissions generated during the operational phase of the building. This accounts for the energy consumed and GWP generated for the lighting, ventilation, central and water heating purposes. Due to the limitations of DEAP [15], the energy consumed and GWP emissions generated by building appliances (e.g. kitchen appliances, laundry equipment, TVs, etc.) are not accounted for. OE and OC can be expressed mathematically as:

$$OE = \sum_1^n PE_i F_i Y \quad (3)$$

$$OC = \sum_1^n PC_i PE_i F_i Y \quad (4)$$

where  $PE_i$  ( $MJ_{prim}/MJ_{del}$ ) is the primary energy conversion factor,  $F_i$  ( $MJ_{del}/m^2/year$ ) is the delivered energy per heated floor area per year,  $Y$  is the lifespan of the building (60 years) and  $PC_i$  ( $kgCO_2/MJ_{prim}$ ) is primary GWP conversion factor of fuel type  $i$ .

The primary energy conversion factor of electricity and gas are taken as  $2.37 MJ_{prim}/MJ_{del}$  and  $1.10 MJ_{prim}/MJ_{del}$  [15], respectively, throughout the building's 60 year lifecycle. The GWP intensity conversion factor of electricity and gas are taken as  $0.145 kgCO_2/MJ$  and  $0.056 kgCO_2/MJ$  [15], respectively, throughout the building's 60 year lifecycle. Using the delivered energy of the respective fuels to each of the case study buildings and current Irish residential energy prices [56,57], operational costs of the case study buildings are determined. 2014 Irish residential electricity and gas prices of  $0.055 €/MJ$ ,  $0.016 €/MJ$  are assumed for this study [56,57] and do not include Value Added Tax (VAT).

Using the total values of EE, OE, EC, OC, NCC and operational economic costs (OEC), life cycle energy, GWP emissions and economic costs of the case study buildings are evaluated.

### 3.3 Case study buildings

In this paper, a south orientated semi-detached residential two storey masonry building (106 m<sup>2</sup> heated floor area) is chosen as a case study design template (Figure 1). This is a gas-to-water space heated dwelling, with features typical of residential construction practice in many Irish homes [58]. For this study, BER's are determined from plans of the dwellings at design stage, with resulting operational energy and operational GWP intensities utilised.

Six different versions of the semi-detached building are investigated. Table 5 summarises the differences in the case study buildings in terms of their building standard, ventilation method, airtightness and ventilation method characteristic's. Table 6 summarises the differences in the case study buildings in terms of their space and water heating systems and installed renewable technologies. Energy and GWP intensity values for the space and water heating energy sources and renewable technology are sourced from Refs. [59–62]. Table 7 summarises the primary element systems utilised in the case study houses.

The first two case study buildings comply with 2005 and 2007 Irish residential building energy performance regulations Technical Guidance Document (TGD) Part L, respectively [13,36] (Table 1 and Table 4). The next two case studies (case study 3a and 3b) comply with the 2011 Irish residential building energy performance regulations TGD Part L [14] using two different design strategies. The first strategy (case study 3a) achieves compliance using building fabric, ventilation and air tightness performance criteria which pass current Irish Building Regulations requirements [14,63]. The second strategy (case study 3b) focuses on a building with a higher building fabric energy performance. It achieves compliance using building fabric, ventilation and air tightness

performance criteria which meet passive house standards [64] with less reliance on renewable energy technologies (see Table 5, Table 6 and Table 7).

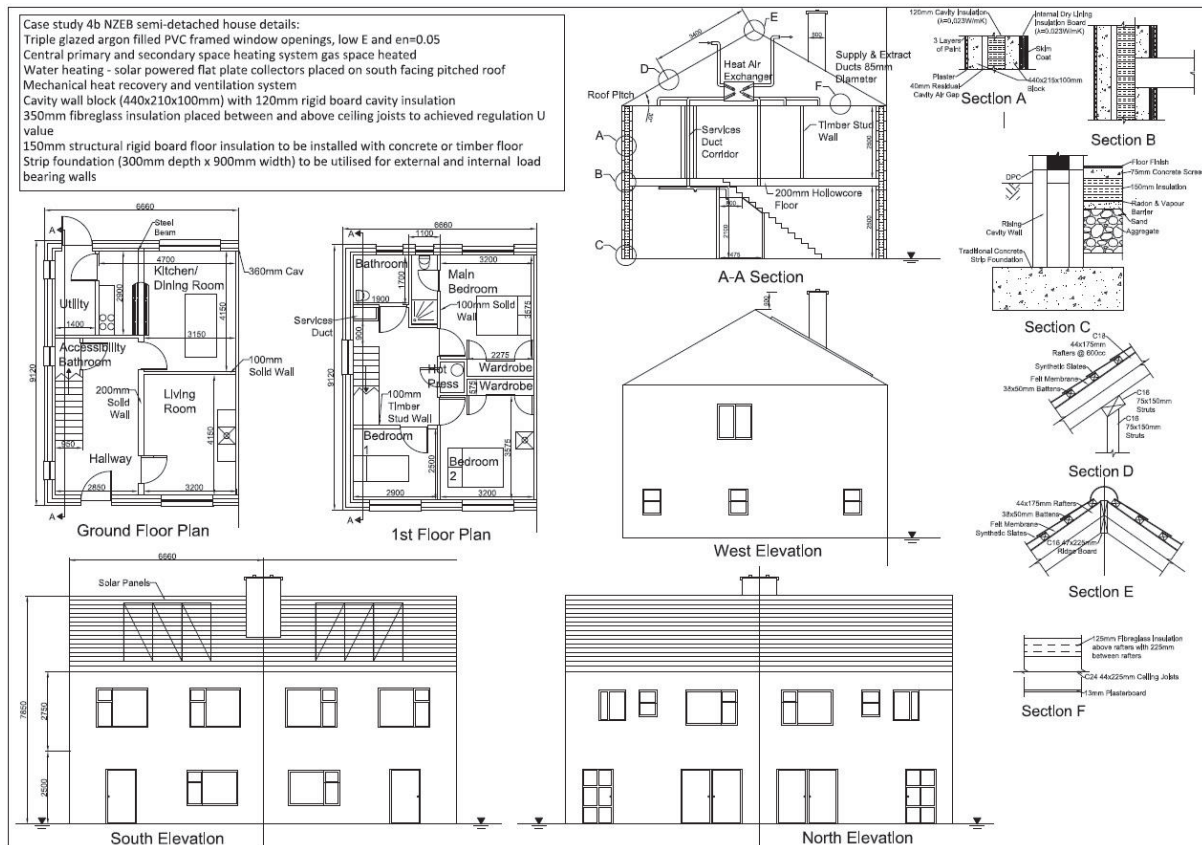

**Figure 1:** Design plans and elevations for case study semi-detached houses

The final two case studies (case study 4a and 4b) comply with the forecast NZEB Irish residential building energy performance regulations (Table 1) using two different strategies. The first strategy (case study 4a) focuses on the use of renewable technologies to achieve a NZEB standard. It achieves compliance using the same building fabric, ventilation and air tightness strategy as case study 3a (Table 7). The amount of renewable technologies installed in the building is increased in order to achieve a NZEB standard (Table 5). The second strategy (case study 4b) focuses on a building with a high building fabric energy performance (Table 7). The same design strategy as

Please cite: Goggins, J., Moran, P., Armstrong, A., Hajdukiewicz, M. (2016) 'Life cycle environmental and economic performance of Nearly Zero Energy Buildings (NZEB) in Ireland'. *Energy and Buildings* (in press). DOI 10.1016/j.enbuild.2016.01.016

case study 3b is used (Table 7), but includes extra renewable technologies to achieve a NZEB standard (Table 5).

Evacuated tube solar collectors (ETSC), with aperture area of 3.23 m<sup>2</sup> area and 0.727 zero loss collector efficiency and multi-crystalline photovoltaics (MCPV), with a 13.2% efficiency are the utilised renewable technologies. For a south orientated building in Ireland, annual solar radiation of 3866 MJ/m<sup>2</sup> is assumed [15]. The heat recovery ventilation unit is assumed to have a specific fan power of 1.04 W/l/s and heat recovery efficiency of 89% for case studies 3b and 4b. As it is a common practice in Ireland, a secondary space heating system, i.e. a gas fire, is installed in the living room of each of the case study buildings. The EE and EC of the gas fire is not accounted for in the analysis.

A schematic of the heating and electricity system of the case study buildings is shown in Figure 2. Evacuated tube solar collectors (ETSC's) are used in tandem with the gas boiler for the generation of hot water for domestic purposes.

Multi-crystalline photovoltaics (MCPV) panels are used to generate electricity for the pumps, ventilation and lighting requirements of the case study buildings. It does not account for the use of domestic appliances due to the limitations of DEAP [15]. The MCPV system allows generated electricity not consumed by the case study buildings to be exported back to the electricity grid. Residences in Ireland are currently being offered 2.5 c/MJ to export electricity onto the national grid [65]. The price of MCPV had drastically decreased [66] since the publication of Spons Construction Price Book (2008) [54]. Therefore, 2013 price of photovoltaic systems in Italy is assumed as the price of MCPV in this study [66].

**Table 5:** General characteristics of the six case studies

Case Study	Building Standard	Heated Floor Area m <sup>2</sup>	Airtightness (ac/hr @ 50 Pa)	Ventilation	Mechanical Ventilation System Characteristics SPF: W/l/s; HRE: %
1	2005	106	9.1	NV and MV	N/A
2	2008		5.44	NV and MV	N/A
3a	2011		5.44	NV and MV	N/A
3b	2011		0.45	MVHR	SPF : 1.04; HRE: 89
4a	NZEB		5.44	NV and MV	N/A
4b	NZEB		0.45	MVHR	SPF : 1.04; HRE: 89

NV\*= Natural Ventilation (Purge Ventilation via windows in habitable room and open flue in living room)

MV\*\*=Mechanical Ventilation (Extract Fan of 10m<sup>3</sup>/h in kitchen and bathrooms)

MVHR=Mechanical Ventilation with Heat Recovery, SPF: Specific Fan Power, HRE: Heat Recovery Efficiency

**Table 6:** Space and water heating systems and installed renewable technologies of the case study buildings.

Case Study	Main heating system	*Secondary space heating system	Efficiency System	Heating	Renewable Technology	
No.					ETSC (m <sup>2</sup> )	MCPV (m <sup>2</sup> )
1	Gas boiler	Gas Fire	Main: 80.5%, Sec: 80%		0	0
2	Gas boiler	Gas Fire	Main: 91.3%, Sec: 80%		3.23	0
3a	Gas boiler	Gas Fire	Main: 91.3%, Sec: 80%		6.46	9
3b	Gas boiler	Gas Fire	Main: 91.3%, Sec: 80%		3.23	0
4a	Gas boiler	Gas Fire	Main: 91.3%, Sec: 80%		6.46	16
4b	Gas boiler	Gas Fire	Main: 91.3%, Sec: 80%		6.46	3

ETSC= Evacuated Tube Solar Collector, MCPV= Multi-crystalline Photovoltaics, SPF=Seasonal Performance Factor

\*Secondary heating systems account for 10% of space heating requirements



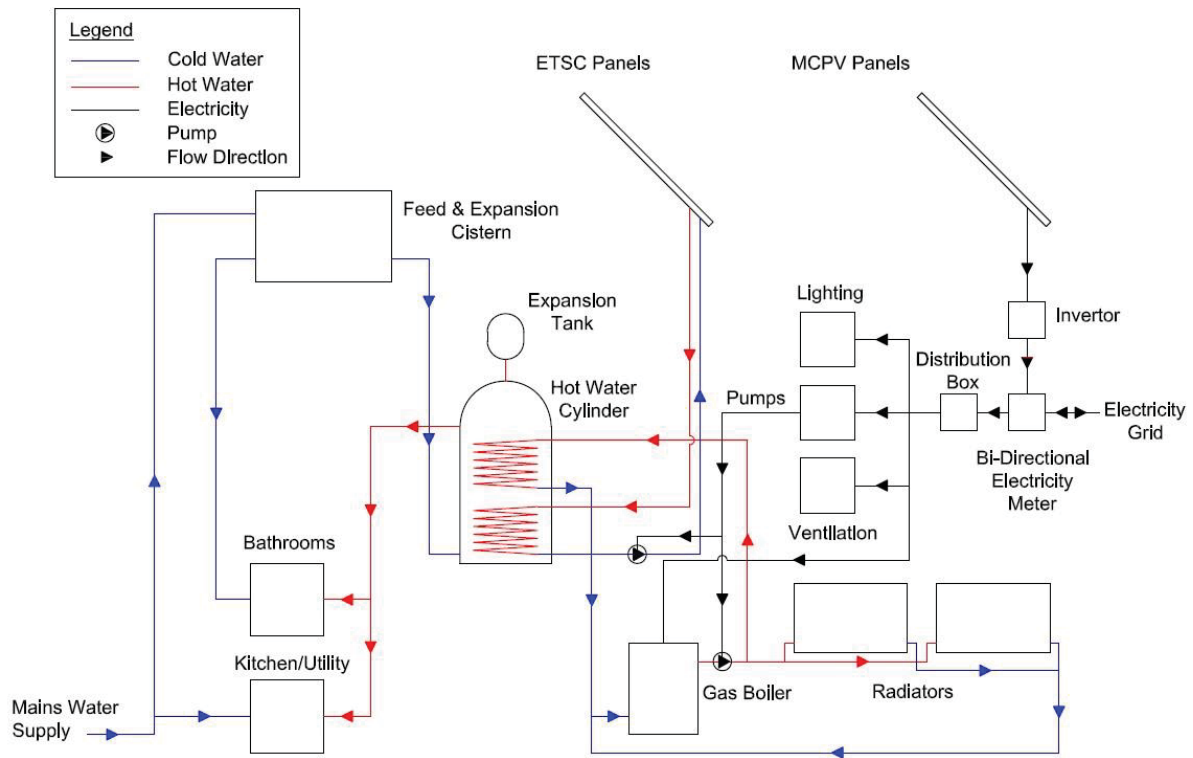

**Figure 2:** Schematic of the case study buildings heating and electrical system

#### 4 Results

Table 7 summarises the EE, EC and U-values of the building element systems utilised in the six case study buildings. The functional unit of each of the systems is the surface area ( $\text{m}^2$ ). U-values for typical external wall, pitched roof and floor systems are determined according to Ref. [14]. Figure 2 demonstrates the calculated lifecycle energy, GWP and economic breakdown of each of the analysed case studies. Table 8 highlights the percentage increase in terms of energy, GWP and economic costs of each of the case study buildings compared to the case study designed to meet the minimum standards set out in the 2005 Irish Building Regulations [13].

Initial ‘cradle-to-gate’ process based EE and EC intensities per  $\text{m}^2$  of heated floor area are 3619  $\text{MJ}/\text{m}^2$  and 369  $\text{kgCO}_2\text{e}/\text{m}^2$  respectively, for the baseline scenario (Case Study 1) (Table 8, Figure

3(a)-(b)). A lifecycle energy breakdown of 89% and 11% for OE and EE respectively, was found for this case study building (Figure 3(a)). OC and EC are responsible for 81% and 19% respectively, of lifecycle GWP accounted for in this analysis (Figure 3(b)).

From the economic analysis, a NCC of 776 €/m<sup>2</sup> was estimated. This is the lowest recorded net construction cost calculated for all case study houses (Figure 3(c)). The OPC over a 60 year period was 477 €/m<sup>2</sup>, assuming no change in fuel prices and no further retrofitting.

The lowest investment in EE which produces the largest OE savings is moving from the 2005 [13] to the 2008 Building Regulations [36] (Table 8). The main differences between the both scenarios are the improvement in the U-value of windows, introduction of a more efficient gas boiler, improved air tightness and the installation of an evacuated tube solar collector. Thus, an increase of 2.27% in EE leads to a reduction of 30.2% of the baseline OE. A similar pattern follows for the GWP analysis. The investment in EE is paid back within 0.58 years due to savings in OE. The investment in EC is paid back within 0.51 years due to savings in OC.

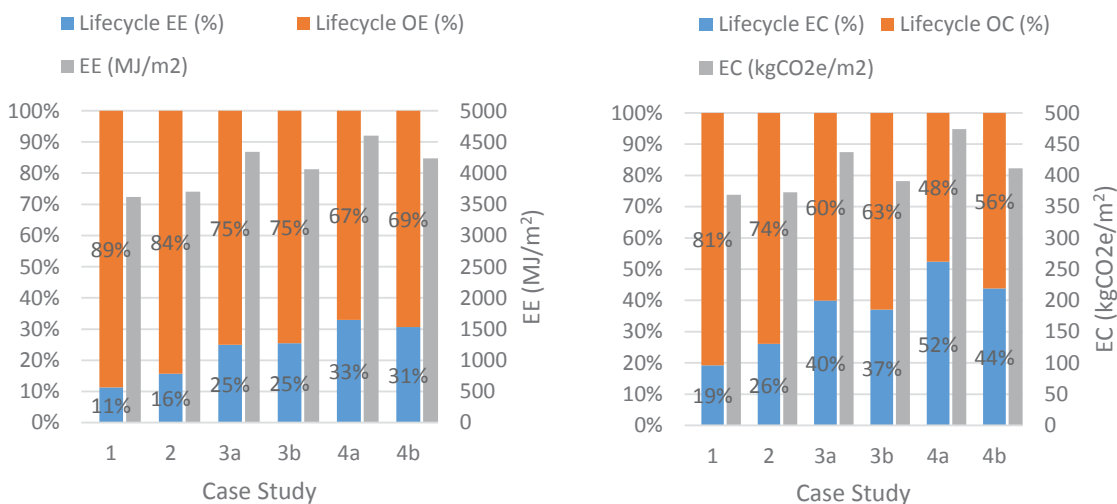

**Figure 3(a):** Estimated life cycle energy including embodied energy (EE) and **Figure 3(b):** Estimated life cycle GWP breakdown including embodied global warming potential (EC) of a typical semi-detached home in Ireland over a 60 year lifespan

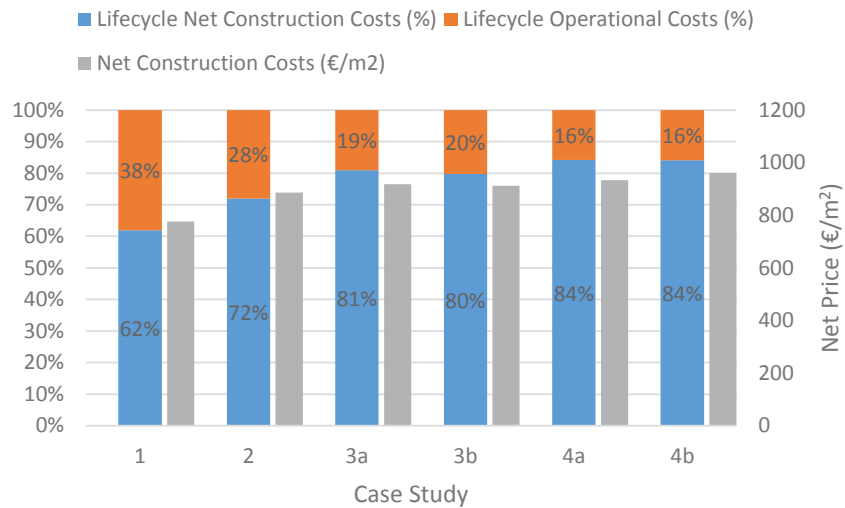

**Figure 3(c):** Estimated life cycle economic breakdown including net construction costs (NCC) of a typical semi-detached home in Ireland over a 60 year lifespan

**Table 7: Building element systems utilised in the case study houses per m<sup>2</sup> of surface area**

Descriptions	Case Study House	U Value (W/m <sup>2</sup> K)	EE (MJ/m <sup>2</sup> )	EC (kgCO <sub>2e</sub> /m <sup>2</sup> )
<b>Typical external wall systems*</b>				
Cavity block wall, 440x225x100mm dense concrete masonry block internal and external leaf, 80mm cavity rigid board insulation ( $\lambda=0.023$ W/mK), 40mm residual cavity air gap, 19mm external render, 12.5mm internal plaster, 5mm gypsum plaster coat ('skim coat'), 3 layers waterborne paint each side	1, 2	0.27	329	30
Cavity block wall, 440x225x100mm dense concrete masonry block internal and external leaf, 100mm cavity rigid board insulation ( $\lambda=0.023$ W/mK), 40mm residual cavity air gap, 29.5mm internal dryling insulation board ( $\lambda=0.023$ W/mK), 19mm external render, 5mm gypsum plaster coat ('skim coat'), 3 layers waterborne paint each side	3a, 4a	0.20	432	36
Cavity block wall, 440x225x100mm dense concrete masonry block internal and external leaf, 120mm cavity rigid board insulation ( $\lambda=0.023$ W/mK), 40mm residual cavity air gap, 29.5mm internal dryling insulation board ( $\lambda=0.023$ W/mK), 19mm external render, 5mm gypsum plaster coat ('skim coat'), 3 layers waterborne paint each side	3b, 4b	0.17	459	37
<b>Typical internal wall systems</b>				
Solid block wall, 440x225x100mm dense concrete masonry block, 12.5mm sand and cement plaster each side, 5mm Gypsum plaster coat ('skim coat'), 2 layers waterborne paint each side	1, 2, 3a, 3b, 4a, 4b	-	252	29
Timber frame wall, 12.5mm sheathing board covering timber studs, 5mm Gypsum plaster coat ('skim coat') each side, 2 layers waterborne paint each side	1, 2, 3a, 3b, 4a, 4b	-	375	12
<b>Typical pitched roof systems</b>				
Standard timber gable-end roof, rafters (44x175mm), ceiling joists (44x225mm), ceiling insulation 275mm fibreglass ( $\lambda=0.044$ W/mK), synthetic slates finish	1, 2	0.15	671	42
Standard timber gable-end roof, rafters (44x175mm), ceiling joists (44x225mm), ceiling insulation 300mm fibreglass ( $\lambda=0.044$ W/mK), synthetic slates finish	3a, 4a	0.14	683	43
Standard timber gable-end roof, rafters (44x175mm), ceiling joists (44x225mm), ceiling insulation 350mm fibreglass ( $\lambda=0.044$ W/mK), synthetic slates finish	3b, 3b	0.12	707	44
<b>Typical window openings system</b>				
12mm double glazed argon filled PVC framed windows, low E, en=0.2	1	2.1	560	182
12mm triple glazed argon filled PVC framed windows, low E, en=0.05	2, 3a, 4a	1.4	592	181
20mm triple glazed argon filled PVC framed windows, low E, en=0.05	3b, 4b	0.8	600	181
<b>Typical floor and foundation systems</b>				
C20 strength concrete strip foundation with 4% steel reinforcement (width 900mmx depth 300mm), 100mm rigid board insulation ( $\lambda=0.035$ W/mK), damp proof membrane and radon barrier included, 75mm concrete screed with vinyl floor finish	1, 2	0.23	1,999	199

C20 strength concrete strip foundation with 4% steel reinforcement (width 900mmx depth 300mm), 120mm rigid board insulation ( $\lambda=0.031\text{W/mK}$ ), damp proof membrane and radon barrier included, 75mm concrete screed with vinyl floor finish	3a, 4a	0.18	2,063	201
C20 strength concrete strip foundation with 4% steel reinforcement (width 900mmx depth 300mm), 150mm rigid board insulation ( $\lambda=0.031\text{W/mK}$ ), damp proof membrane and radon barrier included, 75mm concrete screed with vinyl floor finish	3b, 4b	0.15	2,158	205
200mm hollow core concrete suspended floor with 10mm wood timber flooring and adequate gypsum ceiling plasterboard finish	1, 2, 3a, 3b, 4a, 4b	-	703	72

\*U-values include a correction factor of 0.02 W/m<sup>2</sup>K accounting for the use of wall ties

**Table 8:** Percentage increase in terms of energy, GWP and costs of case studies compared to baseline case study (case study 1)

Indicators	Baseline-Case 1	Difference (%)				
		2	3a	3b	4a	4b
EE	382,983 MJ	2.	20	12	27	17
OE	3,005,365 MJ	-30	-54	-58	-67	-66
EC	39,004 kgCO <sub>2e</sub>	1	19	6	29	11
OC	164,031 kgCO <sub>2e</sub>	-32	-58	-57	-72	-66
Construction Cost	€82,138	14	18	18	20	24
Operational Cost	€50,475	-28	-55	-51	-63	-62

#### 4.1 Super-insulate vs Renewable Technology

Two different design scenarios are investigated in order to achieve the 2011 Building Regulations [14] (case study 3a and 3b) and a NZEB standard (case study 4a and 4b). Scenario 3a and 4a focus more on the installation of renewable technologies (ETSC and MCPV), with building fabric material, airtightness and ventilation strategies just meeting the minimum requirements set out in the current Irish Building Regulations [14,63]. Scenario 3b and 4b focus on utilising a high energy performance building fabric with a smaller amount of renewable technology in order to achieve 2011 Building Regulations [14] and NZEB building energy requirements.

The design method has a significant impact on achieving a building that complies with 2011 regulations. The strategy that focuses on the high building fabric energy performance outperforms the renewables strategy counterpart in terms of both EE and EC. This is due to the high embodied impact of MCPV. However, the strategy that focuses on the high building fabric energy performance outperforms the renewables strategy counterpart in terms of OC. Case study 4a and 3a produce the first and third smallest amount of GWP gas emissions during their operational phase. This is due to the high primary GWP factor of 0.145 kgCO<sub>2</sub>/MJ of the Irish electrical grid and the savings caused by the large installation of MCPV in both case studies. However, with the electricity grid expected to become more decarbonised, the impact of the MCPV will be less significant in the future [45] in reducing a buildings operational GWP impact.

The final case study (4b) consumes the least amount of energy during its lifespan compared to others. In fact, to be constructed case study 4b requires 104 MJ/m<sup>2</sup> of EE less than case study 3a and 42 €/m<sup>2</sup> of construction materials more than the case study 3a. The construction of case study 4b requires 362 MJ/m<sup>2</sup> less than the renewables focused strategy of 4a.

Despite the operational cost of the renewables focused strategy being less than the building fabric focused strategy, it is shown from these case studies that over the life span of the building it is better to focus on the building fabric rather than renewables. To achieve a NZEB status for case studies 4a and 4b, more renewable technology was installed in comparison to case studies 3a and 3b. In fact, due to the large amount of PV installed in case study 4a (16m<sup>2</sup>) and 3a (9m<sup>2</sup>), the building is an exporter of electricity onto the electrical grid. These case studies makes an annual saving of €93 and €22 for exporting electricity, respectively. With this annual saving for exporting

electricity, case study 4a has the lowest annual OEC. It is also the lowest consumer of energy and generator of GWP emissions during the operational phase of the buildings lifecycle

The current offer of 2.5 c/MJ to export electricity onto the national grid is no longer accepting new applications for the incentive. The offer of 2.5 c/MJ has being extended to the applicants registered before the end of 2014 to the end of 2016. It is not expected that customers will be offered money to sell electricity back to the grid for the buildings 60 year lifespan. If there was no price given for electricity to be exported back onto the national grid, case study 4a would no longer be the design with the optimal OEC. Case study 4b would become the optimum solution in terms of OEC.

#### **4.2 Mechanical Ventilation with Heat Recovery System**

One of the main differences in moving from 2011 building standards to nZEB (or passive house) standards is the introduction of a MVHR system. The EE and EC intensities of the MHRV unit and associated ducting employed in this study are provided in Table 9. The list of materials is based on a ProAir PA 600LI heat recovery ventilation system [67]. The embodied impacts of the materials were sourced from the ICE database [47]. If the material impact did not exist within this database, the Cumulative Energy Demand (MJ/kg) and Global Warming Potential (kgCO<sub>2e</sub>/kg) material impacts were sourced from the Ecoinvent version 2 database [68]. The component with the largest EE impact is the ducting used for the supply and extraction of air from the building. This highlights the impact of developing an efficient design with the minimum amount of ducting for a ventilation system within a building.

In terms of the operation for case study 4b, the interaction of the buildings envelope materials has a large impact on the operational savings of the MVHR. The impact of removing the extract fans installed in case study 4a and increasing the air-tightness reduces the OE of the building by 28.1

MJ/m<sup>2</sup>/year. The introduction of the MHRV unit and associated ducting reduces the OE by a further 40.8 MJ/m<sup>2</sup>/year. It therefore takes 1.4 years for the MVHR unit to recover the energy used in the manufacturing of the system and 3.5 years to recover the GWP emitted in the manufacturing phase.

However, based on figures obtained using the Dwelling Energy Assessment Procedure (DEAP) [15], an OE saving of 28.7 MJ/m<sup>2</sup>/year is achieved by the MVHR system. This assumes that the extract fans installed in case study 4a are removed, the air-tightness increased, the u-values of the thermal envelope improved to passive standards (Table 7) and the MVHR system installed. This results in an energy payback period of 2 years for the MVHR unit to recover the energy used in the manufacturing of the system and 4.3 years to recover the GWP gases emitted in the manufacturing phase. In terms of the overall EE and EC of case study 4b, the MVHR system account for 1.36% and 1.5%, respectively

**Table 9:** EE and EC impacts associated with MHRV system

Component	EE (MJ)	%	EC (kgCO <sub>2</sub> )	%
Main Insulation Foam	407	6.6	266	40.2
Unit Steel Frame	224	3.6	16	2.5
Heat Exchanger	484	7.9	19	2.9
Fans	203	3.3	12	1.8
Fans Casing	244	4.0	119	18.0
Supply and Extract Ducting	4146	67.4	198	30.0
Supply and Extract Terminals	27	0.4	1	0.2
Supply and Extract Distribution Boxes	78	1.3	13	1.9
Air Filters	8	0.1	1	0.1
Thermal and Acoustic Insulation Ducts	80	1.3	4	0.7
Circular Connections for Supply and Extract Points of MHRV Unit	15	0.2	1	0.2
Sealants	233	3.8	10	1.5
<b>Total</b>	<b>6148</b>	<b>100</b>	<b>661</b>	<b>100</b>



### 4.3 Material choice

The EE contribution to life cycle energy of the case study buildings increases with each of the improving building regulations. For the case study 1, the EE and EC contributes 11% and 19% of the building's environmental life cycle impact. For the two NZEB case studies (4a and 4b), the EE contribution increases to 33% and 31%, with the EC contribution increasing to 52% and 44% respectively. Thus, with OE and OC beginning to have less of an impact on the lifecycle of a building, architects and engineers will need to start focusing more on reducing the impact of these hot spots in a buildings lifecycle.

The material 'hot spots' of each of the studied building assemblies in terms of EE and EC are shown in Figure 4(a) and Figure 4(b). The superstructure (walls, foundations and floors) are the biggest EE and EC contributors in each of the case studies similar to findings from other studies (see, for example, [24,25,28,29,31]). For example, in the case study building the first floor is constructed using a concrete hollow core slab. If a suspended timber floor was installed instead, the EE and EC impact of the floor would be reduced to 2195 MJ and 59 kgCO<sub>2e</sub> compared to the 25709 MJ and 3331 kgCO<sub>2e</sub> associated with a hollow core concrete floor. This reduces the EE impact of the lifecycle energy of the NZEB case studies to 32% and 30% and the EC impact of the lifecycle GWP to 51% and 42% respectively.

Similar for the roofing system. The installation of a fibre slate has an impact of 10113 MJ and 1245 kgCO<sub>2e</sub>. If a concrete tile was specified instead of the fibre slate, this would increase the values of EE and EC to 29120 MJ and 213 kgCO<sub>2e</sub> respectively. This increases the EE impact of the NZEB case studies to 34% and 32% and reduces the EC impact to 52% and 43%, respectively.

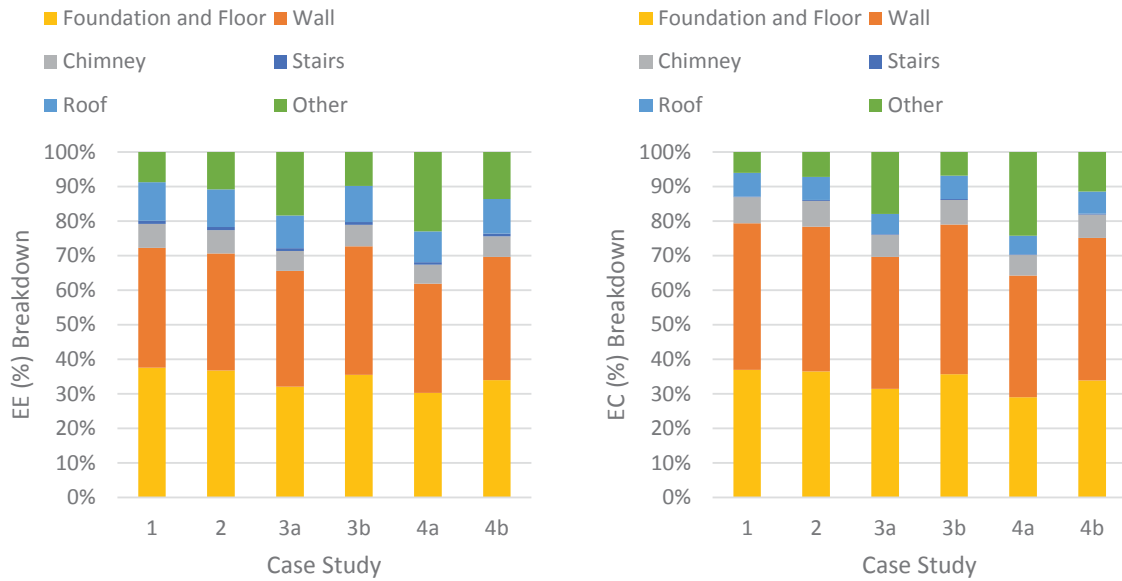

**Figure 4(a):** EE breakdown and **Figure 4(b):** EC breakdown of case study houses according to segregated building assemblies.

## 5 Conclusions

Environmental and economic LCA analysis on case study semi-detached houses designed to previous, current and future building energy performance regulations in Ireland is carried out. Case study semi-detached residential buildings designed to varying degrees of operational performance fluctuate in terms of financial requirements and associated EE and EC intensities.

The emergence of EE and EC as a dominant construction environmental component is vividly noticeable as buildings move towards NZEB standard. For case study 1, the EE and EC contributes 11% and 19% of the building’s environmental life cycle impact. For the two NZEB case studies (4a and 4b), the EE contribution increases to 33% and 31%, with the EC contribution increasing to 52% and 44% respectively. The importance of a designer’s role in sustainably selecting appropriate ‘green’ materials is highly stressed. This is particularly important considering EE and

EC are initial consumptions and emissions, whereas OE and OC occur over the building's lifecycle.

In order to assess if a design strategy is in fact sustainable, it is becoming essential to evaluate environmental and economic LCA of building design strategies. It is often considered that to achieve a higher OE performance, more materials need to be invested into a building. However, if designed with a focus on achieving a high thermal performance and air tightness (case study 4b), a building with a smaller EE intensity, as that which complies with 2011 Irish Building Energy Performance Regulations (case study 3a), can achieve a NZEB standard.

For countries like Ireland, which have a temperate oceanic climate, a key to achieving NZEB is to have high thermal and air tightness performances of the building envelop. A design strategy, which focuses on a building envelop with a high thermal and air tightness properties, is shown to outperform a strategy focusing on the use of on-site generated renewable energy sources in all evaluated life cycle environmental and economic indicators, except for life cycle GWP. However, a static GWP intensity of a MJ of electricity was assumed in this study. The impact of a national electricity mix on a buildings environmental life cycle impact has been highlighted [24,28] and its future decarbonisation [69]. Thus, as the national electricity grid becomes further decarbonised over the coming years, the impact on the proportion of EC in the lifecycle GWP emissions of the buildings will increase and the impact of renewables on OC savings will decrease [45]. It is therefore envisioned that over the buildings lifespan, case study 4b will become the optimum design solution in terms of life cycle GWP impact.

It has been shown that achieving a NZEB status (case study 4a) leads to a building with the lowest life cycle economic cost. However, this is assuming that a building receives 2.5c for every MJ of electricity exported to the grid throughout the buildings life span. As it is not believed that this offer will be for the buildings lifespan, case study 4b is the optimum design in terms of life cycle economic cost if buildings are not given any money for electricity exported to the electricity grid. However, when evaluating the operational costs of the buildings, energy costs were assumed to remain constant for the buildings' lifespan. As the NZEB building has the lowest operational cost, increasing energy prices may have a significant impact on the hierarchy of case studies' lifecycle economic costs.

### **Acknowledgements**

The first author would like to acknowledge the support of Science Foundation Ireland through the Career Development Award programme (Grant No. 13/CDA/2200), as well as the Irish Research Council through a Government of Ireland Postgraduate Fellowship granted to the third author. The authors would also like to acknowledge the funding received from the European Union's Horizon 2020 research and innovation programme under grant agreement No 637221 for the *Built2Spec* project.

### **REFERENCES**

- [1] U.S. EPA & U.S. CPC, *The Inside Story: A Guide to Indoor Air Quality*, Office of Radiation and Indoor Air (6604J), United States Environmental Protection Agency and the United States Consumer Product Safety Commission, 1995.
- [2] UNEB SBCI, *Buildings and Climate Change Summary for Decision Makers*, United Nations Environment Programme Sustainable Buildings & Climate Initiative, 2009.

- [3] European Commission, Directive 2002/91/EC of the European Parliament and of the Council of 16 December 2002 on the energy performance of buildings, Off. J. Eur. Communities. (2002) 65–71.
- [4] [European Commission, Directive 20/31/EC of the European Parliament and of the Council of 19 May 2010 on the energy performance of buildings \(recast\), Off. J. Eur. Communities. \(2010\) 13–35.](#)
- [5] Commission of European Communities, Communication from the Commission to the Council, the European Parliament, the European Economic and Social Committee and the Committee of the Regions Limiting Global Climate Change to 2 degrees Celsius The way ahead for 2020 and beyond, Brussels, 2007.
- [6] European Commission, Energy Roadmap 2050 Impact assessment and scenario analysis, Brussels, 2011.
- [7] DCENR, Delivering a Sustainable Energy Future for Ireland White Paper, Department of Communication Energy and Natural Resources, 2007.
- [8] SEAI, Residential Energy Roadmap 2010-2050, Sustainable Energy Authority of Ireland, Dublin, Ireland, 2010.
- [9] DECLG, National Action Plan on Green Public Procurement (GPP), Department of Environment Community and Local Government, Dublin, Ireland, 2011.
- [10] DCENR, National Energy Efficiency Action Plan 2014, Department of Communications, Energy and Natural Resources, 2013.
- [11] [WCED, Our Common Future: the report of the world commission on environment and development, United Nations World Commission on Environment and Development., 1987.](#)
- [12] DECLG, Our sustainable future - A framework for sustainable development in Ireland, Department of Environment Community and Local Government, Dublin, Ireland, 2012.

- [13] DECLG, Building Regulations 2005 - Technical Guidance Document L - Conservation of Fuel and Energy - Dwellings, Dublin, Department of Environment Community and Local Government, Ireland, 2005.
- [14] DECLG, Building Regulations 2011 - Technical Guidance Document L - Conservation of Fuel and Energy - Dwellings, Department of Environment Community and Local Government, Dublin, Ireland, 2011.
- [15] SEAI, Dwelling Energy Assessment Procedure (DEAP) - Irish Official Method for Calculating and Rating the Energy Performance of Dwellings., Sustainable Energy Authority of Ireland, 2007. [http://www.seai.ie/Your\\_Building/BER/BER\\_Assessors/Technical/DEAP](http://www.seai.ie/Your_Building/BER/BER_Assessors/Technical/DEAP).
- [16] SEAI, A Guide to Building Energy Rating for Homeowners, Sustainable Energy Authority of Ireland, Dublin, Ireland, 2014.
- [17] DECLG, Towards Nearly Zero Energy Buildings In Ireland Planning For 2020 and Beyond, Department of Environment Community and Local Government, Dublin, Ireland, 2012.
- [18] [K. Adalberth, Energy use during the life cycle of single-unit dwellings: Examples, Build. Environ. 32 \(1997\) 321–329. doi:10.1016/S0360-1323\(96\)00069-8.](#)
- [19] [B.N. Winther, a. G. Hestnes, Solar versus green: The analysis of a Norwegian row house, Sol. Energy. 66 \(1999\) 387–393. doi:10.1016/S0038-092X\(99\)00037-7.](#)
- [20] [C. Thormark, The effect of material choice on the total energy need and recycling potential of a building, Build. Environ. 41 \(2006\) 1019–1026. doi:10.1016/j.buildenv.2005.04.026.](#)
- [21] [N. Aste, R.S. Adhikari, M. Buzzetti, Beyond the EPBD: The low energy residential settlement Borgo Solare, Appl. Energy. 87 \(2010\) 629–642. doi:10.1016/j.apenergy.2009.05.029.](#)
- [22] [N. Mithraratne, B. Vale, Life cycle analysis model for New Zealand houses, Build. Environ. 39 \(2004\) 483–492. doi:10.1016/j.buildenv.2003.09.008.](#)

- [23] [I. Zabalza Bribián, A. Aranda Usón, S. Scarpellini, Life cycle assessment in buildings: State-of-the-art and simplified LCA methodology as a complement for building certification, \*Build. Environ.\* 44 \(2009\) 2510–2520. doi:10.1016/j.buildenv.2009.05.001.](#)
- [24] [O. Dahlstrøm, K. Sørnes, S.T. Eriksen, E.G. Hertwich, Life cycle assessment of a single-family residence built to either conventional- or passive house standard, \*Energy Build.\* 54 \(2012\) 470–479. doi:10.1016/j.enbuild.2012.07.029.](#)
- [25] [S. Proietti, P. Sdringola, U. Desideri, F. Zepparelli, F. Masciarelli, F. Castellani, Life Cycle Assessment of a passive house in a seismic temperate zone, \*Energy Build.\* 64 \(2013\) 463–472. doi:10.1016/j.enbuild.2013.05.013.](#)
- [26] J. Jonasson, A two family house built to passive house standard in the north of Sweden-environmental system performance, in: *Proc. Linnaeus ECO-TECH 2014*, Kalmar, Sweden, 2014.
- [27] [A. Passer, H. Kreiner, P. Maydl, Assessment of the environmental performance of buildings: A critical evaluation of the influence of technical building equipment on residential buildings, \*Int. J. Life Cycle Assess.\* 17 \(2012\) 1116–1130. doi:10.1007/s11367-012-0435-6.](#)
- [28] M. Mosteiro-Romero, U. Krogmann, H. Wallbaum, Y. Ostermeyer, J.S. Senick, C.J. Andrews, Relative importance of electricity sources and construction practices in residential buildings: A Swiss-US comparison of energy related life-cycle impacts, *Energy Build.* 68 (2014) 620–631. doi:10.1016/j.enbuild.2013.09.046.
- [29] [J. Bastos, S.A. Batterman, F. Freire, Life-cycle energy and greenhouse gas analysis of three building types in a residential area in Lisbon, \*Energy Build.\* 69 \(2014\) 344–353. doi:10.1016/j.enbuild.2013.11.010.](#)
- [30] [F. Asdrubali, C. Baldassarri, V. Fthenakis, Life cycle analysis in the construction sector: Guiding the optimization of conventional Italian buildings, \*Energy Build.\* 64 \(2013\) 73–89. doi:10.1016/j.enbuild.2013.04.018.](#)

- [31] [M. Cellura, F. Guarino, S. Longo, M. Mistretta, Energy life-cycle approach in Net zero energy buildings balance: Operation and embodied energy of an Italian case study, Energy Build. 72 \(2014\) 371–381. doi:10.1016/j.enbuild.2013.12.046.](#)
- [32] [A. Takano, S.K. Pal, M. Kuittinen, K. Alanne, M. Hughes, S. Winter, Life cycle energy balance of residential buildings: A case study on a hypothetical building model in Finland, Energy Build. 105 \(2015\) 154–164. doi:10.1016/j.buildenv.2015.03.001.](#)
- [33] [K. Tsikaloudaki, K. Laskos, D. Bikas, On the Establishment of Climatic Zones in Europe with Regard to the Energy Performance of Buildings, \(2012\) 32–44. doi:10.3390/en5010032.](#)
- [34] B.S. Limited, Degree Days.net-Custom Degree Day Data, (2014). <http://www.degree-days.net>.
- [35] O. Isachsen, G. Grini, W. Rode, Implementation of the EPBD in Norway: Status in November 2010, Concerted Action Energy Performance of Buildings, 2010. [http://www.epbd-ca.org/Medias/Pdf/country\\_reports\\_14-04-2011/Norway.pdf](http://www.epbd-ca.org/Medias/Pdf/country_reports_14-04-2011/Norway.pdf).
- [36] DECLG, Building Regulations 2007 - Technical Guidance Document L - Conservation of Fuel and Energy - Dwellings, 2007.
- [37] I. Danielski, S.B. Engineering, M. Svensson, S.B. Engineering, S.B. Engineering, Adaption of the passive house concept in northern Sweden - a case study of performance, in: Passivhus Norden 2013, 2013: pp. 1–8.
- [38] [J.N. Hacker, T.P. De Saulles, A.J. Minson, M.J. Holmes, Embodied and operational carbon dioxide emissions from housing: A case study on the effects of thermal mass and climate change, Energy Build. 40 \(2008\) 375–384. doi:10.1016/j.enbuild.2007.03.005.](#)
- [39] [A. Utama, S.H. Gheewala, Life cycle energy of single landed houses in Indonesia, Energy Build. 40 \(2008\) 1911–1916. doi:10.1016/j.enbuild.2008.04.017.](#)
- [40] [A. Chel, G.N. Tiwari, Thermal performance and embodied energy analysis of a passive house - Case study of vault roof mud-house in India, Appl. Energy. 86 \(2009\) 1956–1969. doi:10.1016/j.apenergy.2008.12.033.](#)



- [41] [M.K. Dixit, J.L. Fernández-Solís, S. Lavy, C.H. Culp, Identification of parameters for embodied energy measurement: A literature review, \*Energy Build.\* 42 \(2010\) 1238–1247. doi:10.1016/j.enbuild.2010.02.016.](#)
- [42] [G.P. Hammond, C.I. Jones, Embodied Carbon: The Concealed Impact of Residential Construction, \*Glob. Warm. Enginerring Solut.\* \(2010\) 367–384. doi:10.1007/978-1-4419-1017-2.](#)
- [43] N. O’Loughlin, Embodied CO<sub>2</sub> of housing construction in Ireland, *Archit. Irel.* 247. (2010) 70–71.
- [44] [J. Heinonen, A. Säynäjoki, S. Junnila, A longitudinal study on the carbon emissions of a new residential development, \*Sustainability.\* 3 \(2011\) 1170–1189. doi:10.3390/su3081170.](#)
- [45] C. Jones, Embodied Carbon: A Look Forward, in: *Sustain Insight Artic. Vol. I*, Sustain Consultancy Services, 2011.
- [46] [R.M. Cuéllar-Franca, A. Azapagic, Environmental impacts of the UK residential sector: Life cycle assessment of houses, \*Build. Environ.\* 54 \(2012\) 86–99. doi:10.1016/j.buildenv.2012.02.005.](#)
- [47] G.P. Hammond, C.I. Jones, *The Inventory of Carbon and Energy (ICE)*, 2010.
- [48] DEHLG, *Sustainable Urban Housing : Design Standards for New Apartments-Guidelines for Planning Authorities*, Department of Environment Heritage and Local Government, Dublin, Ireland, 2007.
- [49] Central Statistics Office (CSO) - Statbank, CSO, (2012). <http://www.cso.ie/px/pxeirestat/statire/SelectTable/Omrade0.asp?Planguage=0>.
- [50] [ISO, ISO 14040 - Environmental Management—Life Cycle Assessment—Principles and Framework, International Organization for Standardization, 2006.](#)
- [51] [ISO, ISO 14044 - Environmental Management — Life Cycle Assessment — Requirements and Guidelines, International Organization for Standardization, 2006.](#)

- [52] A. Armstrong, Environmental life cycle assessment study of Irish residential buildings from an energy and carbon perspective, MEngSc thesis, College of Engineering & Informatics, National University of Ireland, Galway, 2013.
- [53] CEN, EN15978: 2011, Sustainability of construction works – Assessment of environmental performance of buildings – Calculation method, European Committee for Standardisation, 2011.
- [54] Taylor & Francis Group, Spon's Irish Construction Price Book - 3rd Edition, Taylor & Francis Group, 2008.
- [55] CSO, Consumer Price Index May 2015, (2015) Central Statistics Office. <http://www.cso.ie/en/releasesandpublications/er/cpi/consumerpriceindexmay2015/#.VZE TjflVhBc> (accessed June 29, 2015).
- [56] SEAI, Electricity & Gas Prices in Ireland Annex Household Electricity Prices per kWh 2nd Semester (July-December) 2014, Sustainable Energy Authority of Ireland, 2015.
- [57] SEAI, Electricity & Gas Prices in Ireland Annex Household Gas Prices per kWh 2nd Semester (July-December) 2014, Sustainable Energy Authority of Ireland, 2015.
- [58] E. Farrell, J. McCarthy, A. McFeely, HOMEBOND House Building Manual, 4th Edition, National House Building Guarantee, 2004.
- [59] BAXI, Baxi Wall Hung Condensing Boiler Luna 4 Environmental Product Declaration, 2009.
- [60] V. Fthenakis, H. Kim, R. Frischknecht, M. Raugei, P. Sinha, M. Stucki, Life cycle inventories and life cycle assessment of photovoltaic systems, 2011. [http://www.bnl.gov/pv/files/pdf/226\\_Task12\\_LifeCycle\\_Inventories.pdf](http://www.bnl.gov/pv/files/pdf/226_Task12_LifeCycle_Inventories.pdf)  
[https://www.bnl.gov/pv/files/pdf/226\\_Task12\\_LifeCycle\\_Inventories.pdf](https://www.bnl.gov/pv/files/pdf/226_Task12_LifeCycle_Inventories.pdf).
- [61] A. Szymanowska, The significance of solar hot water installations in meeting CO2 emissions reduction, University of Iceland & University of Akureyri, 2011. [http://skemman.is/stream/get/1946/7743/20132/1/Anna\\_Szymanowska\\_February\\_2011.PDF](http://skemman.is/stream/get/1946/7743/20132/1/Anna_Szymanowska_February_2011.PDF).

- [62] [L. Yang, R. Zmeureanu, H. Rivard, Comparison of environmental impacts of two residential heating systems, \*Build. Environ.\* 43 \(2008\) 1072–1081. doi:10.1016/j.buildenv.2007.02.007.](#)
- [63] DECLG, Building Regulations 2009-Technical Guidance Document F-Ventilation, Department of Environment Heritage and Local Government, Dublin, Ireland, 2009.
- [64] SEI, Passive homes guidelines for the design and construction of passive house dwellings in Ireland, Sustainable Energy Ireland, 2007. [www.sei.ie](http://www.sei.ie).
- [65] Electric Ireland, Electric Ireland Micro-Generation Pilot Scheme, (2015). <https://www.electricireland.ie/residential/help/micro-generation/electric-ireland-micro-generation-pilot-scheme> (accessed July 31, 2015).
- [66] IRENA, Renewable Power Generation Costs in 2014, International Renewable Energy Agency, 2015.
- [67] ProAir, ProAir 600LI Heat Recovery Ventilation Unit, (2015). <http://www.proair.ie/products/proair-600/> (accessed November 23, 2015).
- [68] [R. Frischknecht, N. Jungbluth, H.-J. Althaus, G. Doka, R. Dones, T. Heck, et al., The ecoinvent database: Overview and methodological framework, \*Int. J. Life Cycle Assess.\* 10 \(2005\) 3–9.](#)
- [69] [A. Lewandowska, A. Noskowiak, G. Pajchrowski, Comparative life cycle assessment of passive and traditional residential buildings’ use with a special focus on energy-related aspects, \*Energy Build.\* 67 \(2013\) 635–646. doi:10.1016/j.enbuild.2013.09.002.](#)