



Provided by the author(s) and University of Galway in accordance with publisher policies. Please cite the published version when available.

Title	A design for environment (DFE) product analysis
Author(s)	Cormican, Kathryn; Dobbs, Jacqueline
Publication Date	2007
Publication Information	Dobbs, J. and Cormican, K. (2007) A design for environment (DFE) product analysis 4th International Product Life Cycle Management Conference Milan, Italy, 2007-07-11- 2007-07-13
Item record	http://hdl.handle.net/10379/4061

Downloaded 2024-05-11T14:07:58Z

Some rights reserved. For more information, please see the item record link above.



A Design for Environment Product Analysis

Jacqueline Dobbs, Kathryn Cormican

Computer Integrated Manufacturing Research Unit (CIMRU),
Industrial Engineering,
National University of Ireland, Galway
00 353 91 524411
J.Dobbs@nuigalway.ie, Kathryn.Cormican@nuigalway.ie

Abstract: Environmental legislation is holding electrical and electronic manufacturers accountable for the disposal of their products at end of life. In order to reduce disposal costs, manufacturers are seeking to optimise product design. Supporting tools are essential at this stage in managing environmental information in order to reduce the products environmental impact. This paper presents findings from an environmental product redesign case study. Specifically, it presents the findings of the Design for Environment Workbench (DFE Workbench) software, in redesigning a torch. The aim of this research is to establish whether the DFE Workbench is adept at reducing the environmental impact of a product. A comparative analysis of the case study results is carried out using a second software tool, Sima Pro. This verifies the 9% reduction in environmental impact achieved through the use of the DFE Workbench. This supports the use of the DFE Workbench as successfully reducing environmental impact.

Keyword: Information management, Tools, Environmental design.

1 Introduction

Inefficient natural resource use is ensuring fossil fuel depletion is occurring at a faster pace than necessary, causing concern for future economic stability. Resultantly, excessive harmful emissions are being produced. This is increasing the rate of climate change with serious implications for health and agriculture internationally. Legislation is targeting electrical and electronic manufacturers to combat this rising trend, as such products account for the fastest growing waste stream in Europe (European Commission 2000). Furthermore, domestic electrical appliances constitute the second largest consumer of electricity (International Energy Agency 2003). The purpose of the legislation is to focus attention on improving environmental product design in order to reduce the inefficient use of materials (and thus natural resource use) and energy e.g. electricity use (and thus excessive greenhouse gas emissions). Legislation has ensured environmental design remains an important company objective by holding manufacturers accountable for the costs associated with product disposal and ensuring financial penalties are in place for non-compliance. This has compelled product manufacturers to consider environmental design, as waste arising from product take-back can often be prevented or minimised by incorporating features that support disassembly, reuse and recycling.

Jacqueline Dobbs, Kathryn Cormican

Design for Environment (DFE) is seen as an effective approach for manufacturers in developing environmentally superior products. DFE is a strategy to minimise the use of natural resources and the consequent impact on the environment. It involves the adoption of life cycle thinking, which ensures the consideration of all life cycle stages during the product design stage (Charter and Tischner 2001). This guarantees that environmental burdens are not simply displaced from one life cycle phase to another.

Design is an information transformation process that needs tools to help integrate additional aims such as DFE. Tools assisting in introducing DFE at the design stage are used to provide: direction, information management and environmental evaluation. DFE tools vary in their proficiency. Quantitative DFE tools range from those that: assist only one life cycle stage to all stages; those that can be learnt over a short period or require an expert user; can offer a simple environmental assessment or a detailed one; and, those which can offer a timely environmental assessment to offering a more time intensive one. This shows that a wide range of DFE tools are available. Baumann et al (2002) and Lindahl (2006), state that too many papers in the area of DFE concentrate on the development of new tools rather than focusing on the degree to which the multitude of already available tools meet the needs of DFE in the design process. Therefore research focusing on already available tools would be an advantage.

This research dealt with these problems by demonstrating the use of one currently available environmental software tool, the DFE Workbench (Roche 2001). This work presents selection criteria detailing desirable attributes of an environmental support tool. The DFE Workbench and its features are discussed to establish to what extent it meets these requirements. The aim of this research is to establish whether the DFE Workbench is adept at reducing the environmental impact of a product. To that end, the DFE Workbench is applied in the environmental analysis and improvement of a torch design. The results of this product analysis show a 9% reduction in the products environmental impact. A comparative analysis of the case study results using a second environmental software tool, Sima Pro, is used to verify the DFE Workbench findings. The findings support the use of the DFE Workbench as able to successfully reduce product environmental impact.

To begin this process, a synthesis of literature in this area will highlight certain traits that maximize the potential for DFE design success in aiding the reduction of environmental impact. This will be followed by a discussion on the DFE Workbench and how it aligns with this assessment criterion.

2 DFE tool assessment criteria

Product designers are in charge of creating profitable product designs that meet the consumers needs. They form the link between the user and a product. Charter and Tischner (2001) state that 80% of the environmental impacts incurred during the life of a product are as a result of the product design stage. The designer although not an environmental expert, plays an important role in influencing this situation (Charter and Tischner 2001; Ernzer and Wimmer 2002; Lindahl 2006). They are involved in the initial product design and development, a phase which influences the way that products are formed and consumed in terms of (Charter and Tischner 2001):

- Fulfilling users needs
- Materials and manufacturing technologies used

A Design for Environment Product Analysis

- Product lifetime
- Recycling and disposal of the product

The literature suggests that in order to allow for better integration into the final design and to lower the environmental impact of the product life cycle, environmental aims should be introduced as early as possible into design development (Ardenete 2003; Charter and Tischner 2001; Fiksel 1996; Goosey 2004; Kuo 2001). The introduction of environmental aims at a later stage, e.g. at the detailed design stage, would result in the introduction of design alterations in a less cost effective manner as many of the important decisions would have already been made (Kuo 2001). For these reasons, it is necessary that a supporting DFE design tool can be used at the concept development stage to ensure greater chance of environmental design success.

Many DFE tools exist. Those used at the design stage assist in the efficiency and success of this phase by helping navigate designers through the unlimited possibilities available (Jensen et al 1999). At a simplified level, DFE tools have two fundamental traits: product improvement and analysis. Tools offering improvement during the design process direct the activity and provide information to the designer (Ferrendier et al 2002). The intention of analysis tools is to measure environmental impact. This may occur before design has begun using a previous design, or after the design is completed to demonstrate the evolution of the design. The presence of metrics assists in confirming environmental practice effort, and helps a firm to monitor and control DFE (Sroufe et al 2000). Glazebrook et al (2000), Lenau and Bey (2001) and Nielsen and Wenzel (2002), also support the use of quantitative methods. They state that such methods are useful at the design stage when deciding on the optimal environmental design, as it enables the designer to compare concept designs in terms of quantifying saved environmental impact. Tools that provide improvement and quantified assessment are therefore an advantage when aiming to reduce environmental product impact.

The tools available have a varying range of functions, from the environmental impacts they account for, data input required and the quality of results that can be obtained. As the number of environmental impacts (effects and emissions) accounted for increases, data pertaining to the products life cycle increases as well as the resource input required. As detail develops the quality of analysis can be said to increase. However, detailed assessments (Full life cycle analysis) tend to be limited in their ability to offer improvement suggestions to the designer, as the detail required for the assessment is often not accessible until the design is in its final stage of development. The literature suggests that a full life cycle analysis is too resource demanding for complex products, to be of practical value to the designer (Fussler 1996; Lenau and Bey 2001; Myklebust et al 1997; Nielsen and Wenzel 2002). Less detailed (Simplified life cycle analysis) tools use approximate data values for calculating the environmental impact of a product. This ensures a much quicker assessment can be carried out and thus environmental improvement to occur at the design stage (Baayen 2000), including easy comparison of the total impact of a product or design possibilities (Glazebrook et al 2000). Whether the tool can be completely utilised at the design stage, is therefore an important feature.

Another aspect of interest, when assessing tools, is whether a software version is available. During the design process a large number of design possibilities are generated. These are then analysed and the best one chosen. Tools enabling quick environmental analysis at the early design stage allow environmentally aware designs to be produced (Baayen 2000). This need for prompt answers is compounded by the fact that short

Jacqueline Dobbs, Kathryn Cormican

innovation cycles are prevalent in the electrical and electronic sector (Schischke et al, 2002).

The last criterion of interest, when assessing tools, is the experience of the actor required to use it. That is, whether an environmental expert is required or whether a person can be easily trained to use it. A tool that is easy to use increases the users speed in adapting to the use of the software and the uptake of tool use during the design stage. It is believed that this would also assist in reducing the intrusion on the design activity (Roche 2001). Lenau and Bey (2001) argue that the purpose of having easy-to-use tools is to allow designers, who have limited environmental knowledge, a chance to learn as they design and because they also have limited time for product development the tool should require minimal effort.

This synthesis of literature has highlighted certain traits that maximize the potential for DFE design success in aiding the reduction of environmental impact. Key assessment criteria include: whether the tool can be used in the product design stage, the degree to which it is improvement and assessment based, the scope of the tool, whether it has a software version available and if it is easy to use. A discussion on the DFE Workbench now follows, setting out how it aligns with this assessment criterion.

3 DFE Workbench

The DFE Workbench is a software tool suitable for integration into a Computer Aided Design (CAD) environment. It provides analysis, synthesis, evaluation and improvement for the whole of the products life cycle (Roche 2001). Five elements make up the structure of the tool, including: the Impact Assessment System, the Structure Assessment Method, an advisor agent, a knowledge agent and a report generator. The *Impact Assessment System* (IAS) is based on a simplified life cycle analysis quantitative method – Eco indicator 95. The IAS enables management of information from across a products life cycle, as well as assessment and prioritization of this data. The *Structure Assessment Method* (SAM) centers on the structure of the products CAD prototype. SAM retrieves data such as: material type, % recycled material content, disassembly time, number and type of fasteners among others. These elements are quantified and form part of the assessment of the overall product impact. SAM also allows for automatic recalculation of the products impact should an aspect of the product (e.g. component type/material) be changed. The *Advisor Agents* job is to provide a prioritization list. This is produced from the IAS and SAM modules, detailing aspects of the products design that is causing most impact. This agent also offers suggestions to the user regarding changes that could be made to the structural characteristics of the product to reduce environmental impact. The *Knowledge Agent* is a consultative aspect of the tool. The user can seek advice from this module for example, if they wanted a material with specific mechanical properties (Roche 2001). The fifth element of the DFE Workbench is the *Report Generator*. This aspect allows for easy comparison of the initial selections against the final ones. This information can be saved in various electronic formats or printed, depending on the users needs.

The traits of the DFE Workbench in relation to the assessment criteria will now be summarised. The tool is such that it can assist with all life cycle stages. Due to the analysis method used, timely data analysis can occur to allow for a high rate of improvement to be introduced early in the product design phase. A medium level of

assessment can be obtained - although this is not ideal, this does allow for improvement to be implemented at the product design stage. In terms of Ease of Use, the author has rated this area highly, having used a number of software tools for the compilation of this research (Dobbs 2007).

4 Product Analysis

Due to changes in legislation, disposal of electrical and electronic products is now the responsibility of the manufacturer. In order to reduce disposal costs, the manufacturer is seeking to improve the environmental design of their products. Design for Environment (DFE) is seen as an effective approach for manufacturers in developing environmentally superior products. Design is an information transformation process that needs tools to help integrate additional aims such as DFE. However, a wide range of DFE tools are available. Baumann et al (2002) and Lindahl (2006), state that too many papers in the area of DFE concentrate on the development of new tools rather than focusing on the degree to which the multitude of already available tools meet the needs of DFE in the design process. Therefore research focusing on the degree to which already available tools meet the needs of the environmental product design stage would be an advantage. This research focuses on one, currently available environmental software tool, the DFE Workbench. Selection criteria detailing desirable attributes of an environmental support tool were highlighted and the degree to which the DFE Workbench met these criteria discussed. The aim of this research is to establish whether the DFE Workbench is adept at reducing the environmental impact of a product. This section presents results of the DFE Workbench having been used in the environmental analysis and improvement of a torch design (figure 1). The environmental profile below (section 4.1) presents the environmental impact analysis carried out after design improvements were introduced.

Figure 1 Exploded view of torch

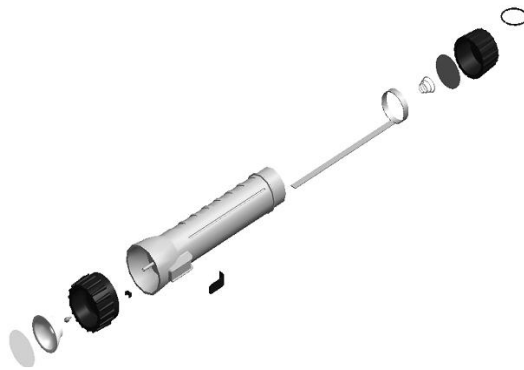

4.1 Environmental Profile

Through the use of the DFE Workbench prioritisation and advisor agent, improvements were made to the overall environmental design of the torch. The new environmental profile of the product is detailed below. The degree of improvement is also listed and was established by comparing the original analysis of the product with the new environmentally improved design.

Jacqueline Dobbs, Kathryn Cormican

Mass of overall product: 0.124kg – no change

Materials used in product composition: Linear Low Density Polyethylene (LLDPE), copper, and one type of steel. Material variety reduced from five to three. This shows a 40% improvement in material variety.

Processes used to make components: Injection moulding and metal cutting – no change

Transport: Truck, 500km – no change

Energy Use: 4.5 Volts – no change

End-of-life strategy: Due to the addition of product labelling, much of the product can now be recycled. This results in a 58% improvement.

Fasteners used: Screwed (2) – reduced by two, snap fit (4) – increased by two, fit in (2) and press fit (6) methods. Changing two of the fastening methods to a snap fit assisted in reducing disassembly time.

Disassembly time: Originally 112s, now 100s, an 11% improvement.

Having completed the environmental improvements for the product, a reassessment of the products environmental impact was carried out using the DFE Workbench. This showed that the overall environmental impact decreased to 1.091mPt (its eco-indicator value), a 9% improvement of the products environmental performance. A comparative analysis of these case study results using a second environmental software tool, Sima Pro, will now be used to attempt to verify the DFE Workbench findings. The findings will then be discussed to account for any result discrepancies that may have arisen.

4.2 Comparative Analysis

The tool used for the primary environmental assessment was the DFE Workbench. The analysis module of this tool uses a Simplified Life Cycle Analysis (SLCA) method, Eco-indicator 95. So that an evaluation of the DFE Workbench results can occur, the tool selected to provide comparison must be of the same family of tools. The tool chosen for this purpose is Sima Pro (Version 7). This tool is within the SLCA grouping, but uses the Eco-indicator 99 assessment method. This section details the results obtained through the use of Sima Pro in the analysis of the improved torch design.

Figure 2 Sima Pro graph showing torch product analysis

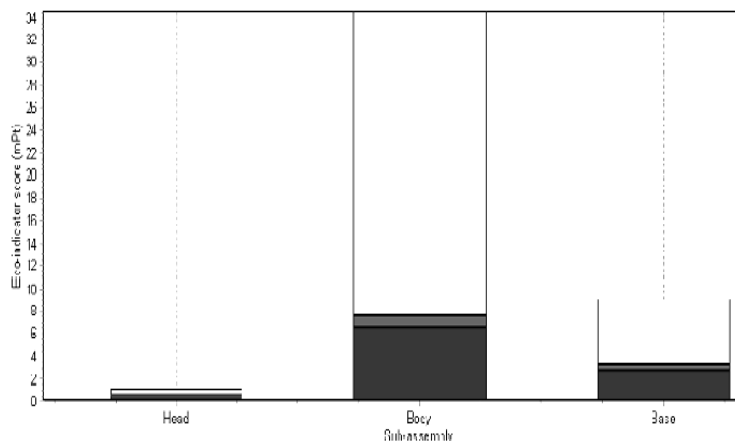

A Design for Environment Product Analysis

Figure 3 DFE Workbench graph showing torch product analysis

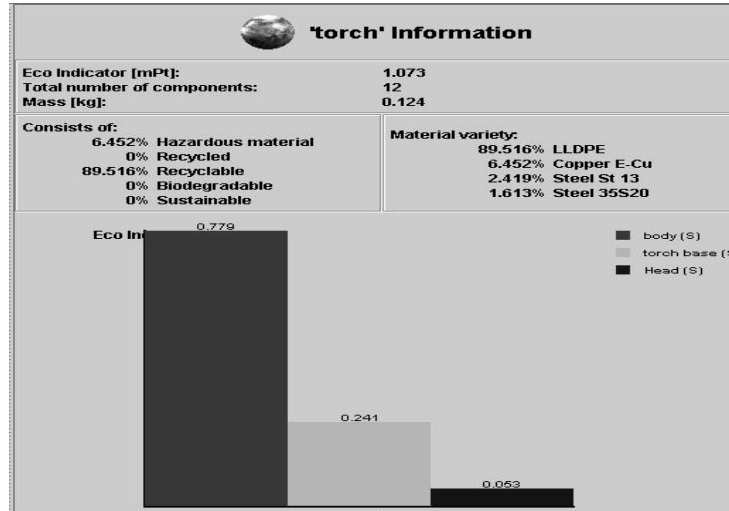

Figure 2, illustrates the findings of the environmental analysis of the torch using the Sima Pro software. The graph shows the analysis of the three main sub-assemblies of the torch, with each bar accounting for their respective eco-indicator value. Figure 2 shows the sub-assembly causing the greatest impact is the body of the torch, followed by the base and then the head. It is not possible to compare scores of the Sima Pro analysis with that of the DFE Workbench since more aspects are taken into account with Sima Pro and a different weighing approach has been used. However, as can be seen from this initial visual inspection of the Sima Pro analysis, the results convey the same message as the DFE Workbench. This can be clearly displayed by comparing the graphical display of Sima Pro shown in figure 2 with that of the DFE Workbench in figure 3. This shows the order of environmental impact for each sub-assembly (body, base and then head) is the same for each assessment method.

Figure 4 Sima Pro impact analysis of body sub-assembly

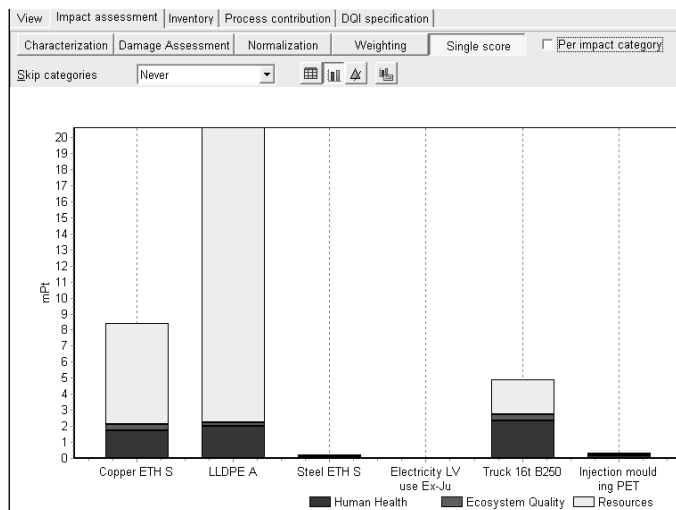

Figure 5 DFE Workbench impact analysis of body sub-assembly

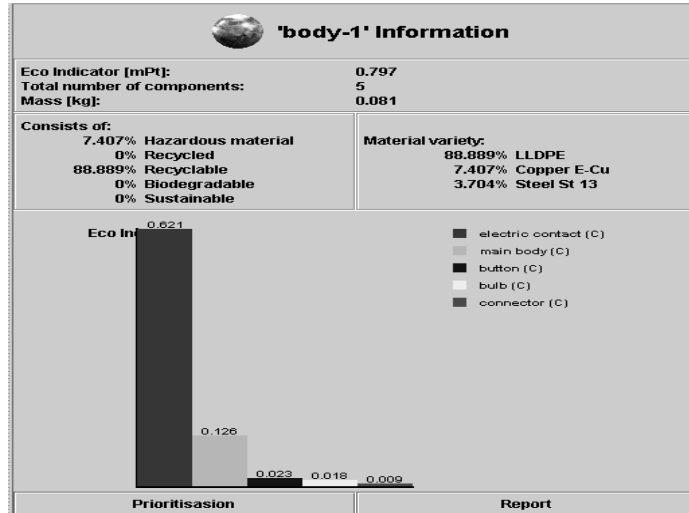
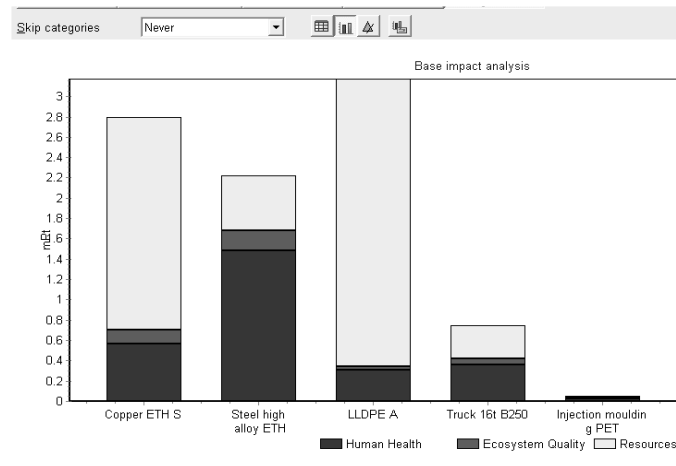

Figure 6 Sima Pro impact analysis of base sub-assembly



A closer look at the results obtained for one of the sub-assemblies of the torch established whether the results for these two assessment methods were also similar at a more detailed level. Figure 4 shows the environmental impact evaluation for the body of the torch using Sima Pro. Figure 5 shows the same sub-assembly but using the assessment results from the DFE Workbench analysis tool. On comparing these two sets of results it can be seen that the bar that accounts for the greatest environmental impact from each bar chart, differs in each. In figure 4, the Sima Pro results for the torch body show that, that which causes most impact is the Linear Low Density Polyethylene (LLDPE) material content (i.e. main body plus button, as Sima Pro groups like materials together). Copper follows this, which is the material of the electric contact. In figure 5, the DFE Workbench analysis results for the torch body shows that the Copper content in

A Design for Environment Product Analysis

the sub-assembly creates most impact. This is followed by the 'main body' which is the part made from LLDPE and then thirdly by the 'button' which is also made from LLDPE.

Figure 7 DFE Workbench impact analysis of base sub-assembly

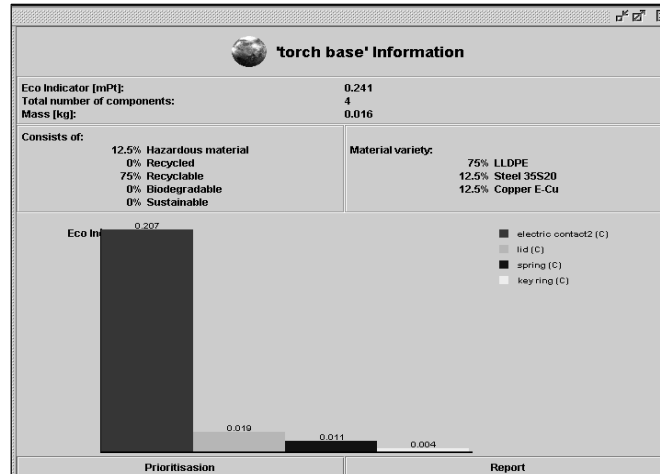

The variance in ranking of the first three elements of the Sima Pro (Eco-indicator 99) results when compared with that of the DFE Workbench (Eco-indicator 95) demonstrates one significant difference. Those materials or processes that have resource input show a higher ranking in the Sima Pro analysis. This can be explained as follows. Eco-indicator 99 accounts for a wider range of effects, one of which is resource depletion, it is reasonable therefore that some of the impacts indicated in the Sima Pro analysis that use fossil fuels are rated as having greater impact than in the DFE Workbench. An example of this is the placement of LLDPE in the Sima Pro analysis of the torch body as creating most impact. However this material accounted for in the DFE Workbench is regarded as the second greatest impact. This same trend can be viewed in the analysis results of the base sub-assembly. Figure 6, the Sima Pro results for the base, shows that LLDPE accounts for the highest impact, followed by the copper and then the steel content. The DFE Workbench (figure 7) results for this same sub-assembly, shows the copper (electric contact2) being placed as causing greatest impact, followed by the LLDPE (Lid) and then the steel (spring). This trend in the relationship between these two sets of results confirms that materials or processes containing resource input are ranked as causing greater impact in the Sima Pro analysis compared with the DFE Workbench. The slight differences between these two analysis results at the detailed sub-assembly level can thus be accounted for due to the heavier weighting, within the Sima Pro analysis, of fossil fuel based materials. On completion of analysis, a common trend can thus be found for the improved torch design by comparing the DFE Workbench results with those of Sima Pro.

5 Conclusion

Supporting tools are essential at the design stage in managing environmental information in order to help reduce a products environmental impact. However a wide range of DFE tools are available, leaving it difficult for the manufacturer to decide which one is

Jacqueline Dobbs, Kathryn Cormican

suitable. In addition to this, too many papers in the area of DFE concentrate on the development of new tools rather than focusing on the degree to which already available tools meet the needs of DFE in the design process. This research dealt with these problems by demonstrating the use of one currently available environmental software tool, the DFE Workbench. This work presented selection criteria detailing desirable attributes of an environmental support tool. The DFE Workbench and its features were discussed to establish to what extent it met these requirements. The aim of this research was to establish whether the DFE Workbench is adept at reducing the environmental impact of a product. To that end, the DFE Workbench was applied in the environmental analysis and improvement of a torch design. Improvements were made to the environmental design of the product using the DFE Workbench. A second environmental analysis using the DFE Workbench showed a 9% reduction in the products environmental impact. A comparative analysis of these results using a second environmental software tool, Sima Pro, was then carried out. Although some slight variances in the results arose, these could be explained due to awareness of the varying characteristics between Eco indicator 95 (DFE Workbench) and Eco indicator 99 (Sima Pro). The comparative analysis confirmed the DFE Workbench findings. This showed that the DFE Workbench is thus valid in its attempts to implement environmental improvement. The successful validation of the case study findings has ensured that the main goals of this research have now been met.

References

- 1 Ardente, F., Beccali, G., Cellura, M. (2003) 'Eco-sustainable energy and environmental strategies in design for recycling: the software ENDLESS', *Ecological Modelling*, vol. 163, pp. 101-118.
- 2 Baumann, H., Boons, F., Bragd, A. (2002) 'Mapping the green product development field: engineering, policy and business perspectives', *Journal of Cleaner Production*, vol. 10, pp. 409-425
- 3 Baayen, H. (2000) 'Eco-indicator 99 Manual for designers', Ministry for housing, spatial planning and the environment, pp. 4-8
- 4 Charter, M. and Tischner, U. (2001) 'Sustainable solutions. Developing Products and Services for the Future', Greenleaf: Sheffield, UK.
- 5 Dobbs, J. (2007) 'A Design for Environment Product Analysis' Thesis, National University of Ireland Galway.
- 6 Ernzer, M. and Wimmer, W. (2002) From environmental assessment results to Design for Environment product changes: an evaluation of quantitative and qualitative methods, *Journal of Engineering Design*, vol. 13 (3) pp. 233--242
- 7 European Commission. (2000) 'Proposal for the directive on waste from electrical and electronic equipment', *European Commission*, Brussels.
- 8 Ferrendier, S., Mathieux, F., Rebitzer, G., Simon, M., Froelich, D. (2002) Eco-design tools and methods, In 'Eco-design Guide: Environmentally improved product design case studies of the European electrical and electronics industry', ECOLIFE Thematic Network, pp. 21-34
- 9 Fiksel, J. (1996) Design for Environment Creating Eco-Efficient Products and Processes, McGraw Hill.
- 10 Fussler, C. (1996) 'Driving Eco-Innovation', Pitman Publishing.
- 11 Glazebrook, B., Coulon, R., Abrassart, C. (2000) 'Towards a product life cycle design tool', *Proceedings of the 2000 IEEE International Symposium on Electronics and the Environment*, 8-10 May, pp. 81-85

A Design for Environment Product Analysis

- 12 Goosey, M. (2004) 'End-of-life electronics legislation - an industry perspective', *Circuit World*, vol. 30(2), pp. 41-45.
- 13 International Energy Agency. (2003) 'Cool Appliances: Policy Strategies for Energy-Efficient Homes', *International Energy Agency*, Paris, France.
- 14 Jensen, A., Hoffman, L., Brigitte T., Schmidt, A., Christiansen, K., Berendsen, S., Elkington, J., Van Dijk, F. (1999) 'European Environment Agency. Life cycle Assessment: A guide to approaches, experiences and information sources', Environmental Issues Report Series No. 6. Accessed from <http://reports.eea.europa.eu>, May 2006.
- 15 Kuo, T. C., Huang, S. H., Zhang, H. C. (2001), 'Design for manufacture and design for 'X': concepts, applications, and perspectives', *Computers and Industrial Engineering*, vol. 41, pp. 241-260.
- 16 Lindahl, M. (2006) 'Engineering designers' experience of design for environment methods and tools – Requirement definitions from an interview study', *Journal of Cleaner Production*. Vol. 14, pp. 487-496
- 17 Lenau, T. and Bey, N. (2001) 'Design of Environmentally friendly products using indicators', *Proceedings of the Institution of Mechanical Engineers*. 215 Part B
- 18 Myklebust, O., Lamvik, T., Storen, S., editors. (1997) 'Nordlist LCA project – life cycle assessment in product development', Oslo: Nordic Industrial Fund.
- 19 Nielsen, P.H. and Wenzel, H. 2002, Integration of environmental aspects in product development: a stepwise procedure based on quantitative life cycle assessment. *Journal of Cleaner Production*.vol.10, pp. 247-257
- 20 Roche, T., Man, E., Browne, J. (2001) ,Development of a CAD Integrated DFE Workbench tool' *In Proceedings of the 2001 IEEE International Symposium on Electronics and the Environment*. Denver, USA, pp.16-24
- 21 Schischke, K., Deubzer, O., Griese, G., Stobbe, L. (2002) 'LCA for Environmental Management and Eco-design in the Electronics Industry – State of the art and screening approaches – Life cycle assessment and life cycle management', E-conference. Available from: www.lcacenter.org/lca-lcm. May 20th 2002
- 22 Sroufe, R., Curkovic, S., Montabon, F., Melnyk, S.A. (2000) 'The new product design process and design for environment – crossing the chasm', *International Journal of Operations and Production Management*. Vol. 20 (2), pp.267-282.