



Provided by the author(s) and University of Galway in accordance with publisher policies. Please cite the published version when available.

Title	Real-time network-storage for digital cameras
Author(s)	Raducan, Iliaru; Bigioi, Petronel; Corcoran, Peter
Publication Date	2012
Publication Information	Raducan, I.,Bigioi, P.,Corcoran, P. (2012) Real-time network-storage for digital cameras Consumer Electronics, IEEE International Conference on
Publisher	IEEE
Link to publisher's version	<a href="http://dx.doi.org/10.1109/ICCE.2012.6161922">http://dx.doi.org/10.1109/ICCE.2012.6161922</a>
Item record	<a href="http://hdl.handle.net/10379/3621">http://hdl.handle.net/10379/3621</a>

Downloaded 2024-05-12T00:03:22Z

Some rights reserved. For more information, please see the item record link above.



# Real-Time Network-Storage for Digital Cameras

Ilariu Raducan, Petronel Bigioi, *Senior Member, IEEE*, and Peter Corcoran, *Fellow, IEEE*  
College of Engineering & Informatics, National University of Ireland, Galway

**Abstract**—Cloud computing suggests that we can move computers from the desktop onto the network. In this paper we investigate the potential to reduce local storage for handheld devices such as digital cameras or smart-phones to the minimum required to acquire and buffer images until they can be off-loaded onto local network storage. The required minimum storage for video and digital still images are analyzed and tested in a practical home networking environment. Our results indicate that as local connectivity becomes faster and more ubiquitous that next generation devices could automate the entire upload, sort and store cycle for personal digital media such as pictures and video clips.

## I. INTRODUCTION

Since the early 2000's, researchers have tried to find new ways to improve the connectivity of digital cameras [1]-[8] and reliably transfer pictures from the camera local storage to an end destination, with minimal involvement on the part of the user. Early work [6], [7] used a dial-up connection but this was soon superseded by Bluetooth [2] and cell-phone network [1] connectivity and then by wireless 802.11b [4]. Later, after the introduction of USB technology in digital cameras, the PTP [3] standard was created to take the full advantage of the increased transfer speeds implementing easy management of capturing and transfer operations.

Eventually, PTP was standardized using an underlying TCP/IP transport over WLAN and LAN networks under the name of PTP/IP [5], [6]. Although not widely adopted for practical applications, PTP/IP does offer mechanisms to extend the device-to-device pairing of PTP over local or even wide-area networks without sacrificing the ease-of-use of PTP itself [6]. In other early work Corcoran and Raducan [4] looked at optimizing the transfer of MJPEG video over an 802.11b network, finding that three concurrent video streams could be supported.

## II. A SIMPLIFIED TRANSFER WORKFLOW FOR CAMERAS

Here we consider the typical user experience with a digital camera. After shooting a few pictures the user has to decide what to do with them. Typically images can be uploaded from the camera to a PC, or a new memory card can be inserted and the old card read, again into a computer, or some cameras feature a dedicated network cradle that will offload pictures after the camera is placed in the cradle. Of course all of these methodologies complicate the use of the camera, as the user has to manage memory cards, cables and cradles. If you own a digital camera, and who doesn't these days, you'll be familiar with this unduly complex user environment..

The key question we want to investigate in this paper is if it is now practical, at least in a home WiFi network, to eliminate the local storage step of managing pictures from a camera. In

other words, all pictures or video clips will be instantly transferred to a local storage directory. Yes, you will have to sort these out later, but at least every image and video clip you shoot in the home environment goes instantly to long-term storage.

### A. Improved Capture Experience

Our improved capture experience is illustrated in the right-most column of Figure 1 below. You'll note how much easier this is than using memory cards, cables or wireless cradles. And by building WiFi into the camera the expectation is that it could work outside your home. But for the purposes of this paper we confine ourselves to the home network scenario.

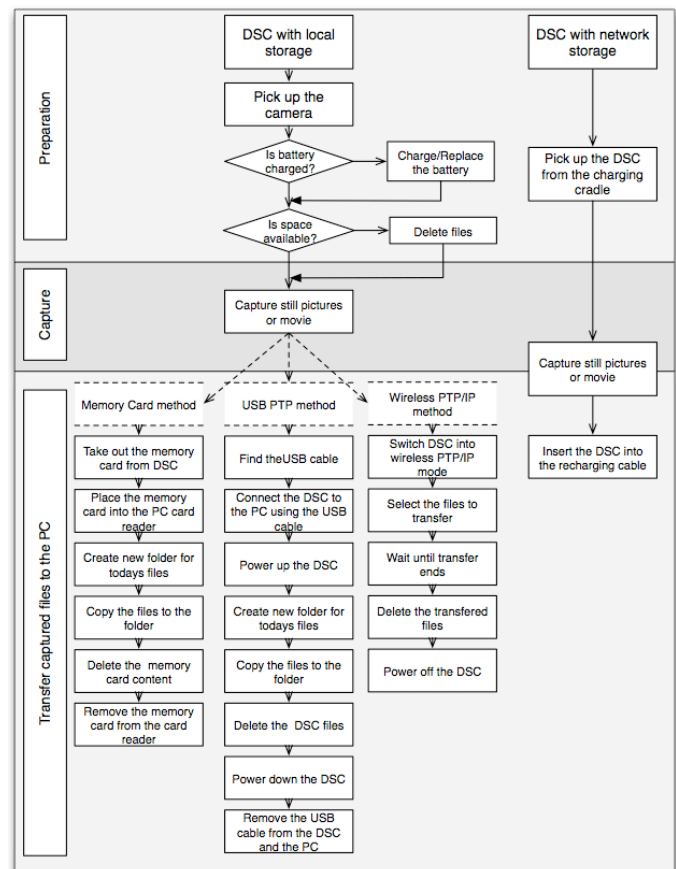

Figure 1: Capture experience for different DSC file transfer workflows.

### B. System Layers

A layered view of system components that may be used to reach the virtual storage from the digital camera is presented in Figure 2. The access-point sits between digital camera and network storage. The link between digital camera and access-point is performed in the wireless network. The network storage reaches the access-point via an Ethernet link. The communication between the digital camera and network

storage passes through the wireless access-point. The access-point plays the role of network bridge for the data packets exchanged between the hosts. Data produced during capture/recording operations travel from the storage client to the 802.11 MAC layer. It is transferred to the access-point using the physical layer of the wireless network. In the access-point the payload of 802.11 data packets is encapsulated in 802.3 MAC packets that are transferred to the network storage device via wires in the Ethernet network. The data packets travel up through the network storage layers to reach the storage device.

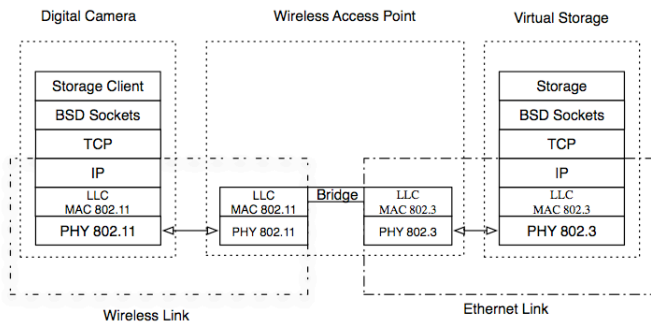

Figure 2: Virtual Storage for Digital Cameras: System Layers

### III. IMPLEMENTATION

#### A. System Overview

The test system comprises three main modules shown in Figure 3 below. Each of these must be modified to enable the overall system, although many of the modifications are relatively trivial. In this short abstract we focus on the main modifications to the camera and storage systems.

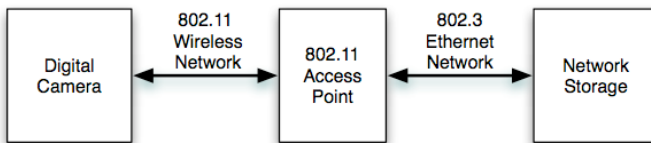

Figure 3: Overview System Model

#### B. Digital Camera Architecture

The DSC architecture requires the most significant changes as illustrated in Figure 4. Firstly, several software components within the camera are modified to allow control of the quantity of data produced: video bit-rate or the interval between successive image capture events for still image capture. Thus the video recording subsystem is replaced by a *Video Data Producer* and still image capture is replaced by the *Still Data Producer* software module.

Secondly, a number of software subsystems are added to the digital camera. These subsystems forward data in a controlled manner from the data producer to the network storage. Most importantly, the *RAM buffer* accumulates data at production rate(s). Data is removed from *RAM buffer* by the *Network Storage Client* module. Data removal rate varies with the wireless network conditions. *Control Module* monitors the utilization of *RAM buffer*, the utilization of the TCP buffers and the wireless link speed. Based on the monitoring of these three subsystems, *Control Module* adjusts the data production

rate(s) of the video and still image subsystems.

Thirdly, hardware and software subsystems are added to the DSC platform to enable the actual data transfer. These are the TCP/IP stack, the wireless network cards, and the wireless network card driver.

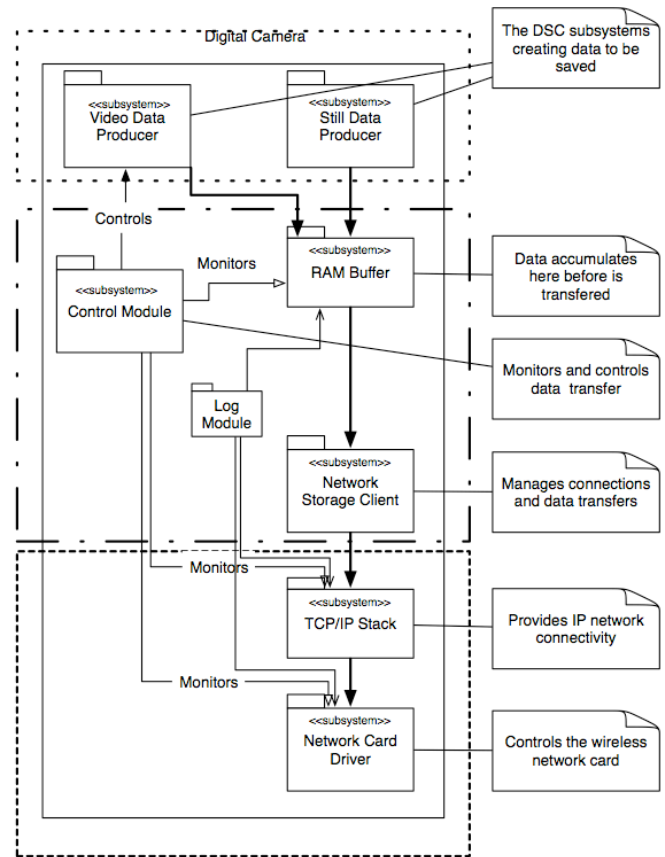

Figure 4: Required Changes to Standard Digital Camera Architecture

#### C. Network Storage Architecture

Figure 5 illustrates the additional subsystems required by the Network Storage system component. *Network Storage Server* is a server module that waits for TCP/IP connections from camera devices. When a connection is validated, the server allocates a RAM buffer similar to that used in the modified camera architecture. This ensures that the *Network Storage Server* spends very little time serving each client, resulting in a low latency service.

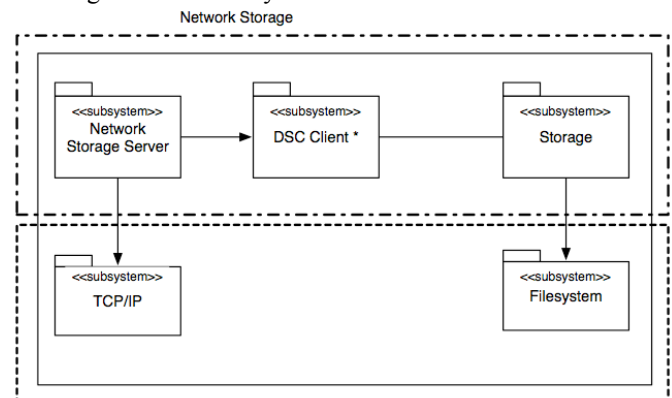

Figure 5: Network Storage Architecture

#### IV. EXAMPLE TEST RESULTS

Here we can only present a small sub-set of our test results. The following examples give some idea of the more detailed testing program to investigate multiple combinations of still and video cameras operating concurrently. The tests detailed below were measured using 12 Megapixel JPEG images for the still image transfers and standard definition VGA (SD) and 720p resolution video clips were used to test movie capture.

##### A. Still Image Capture - Single Camera

This scenario was tested with two configurations: in a 802.11g network and in a 802.11n network. Generally, the still pictures were transferred without problems at a rate of a 12 Mega-pixel picture every 2 seconds. This picture capture rate is perfectly acceptable for a low-end digital camera. A typical plot of the still picture capture transfer is depicted in figure 6(a). It shows 15 consecutive still pictures taken at 2 seconds intervals. All pictures were transferred from a central location within the house.

As each picture is captured the resulting JPEG representation is stored in the RAM buffer. From there, the application retrieves smaller data blocks and writes them to the network socket. The socket buffer remains relatively fully occupied until each whole picture is transferred.

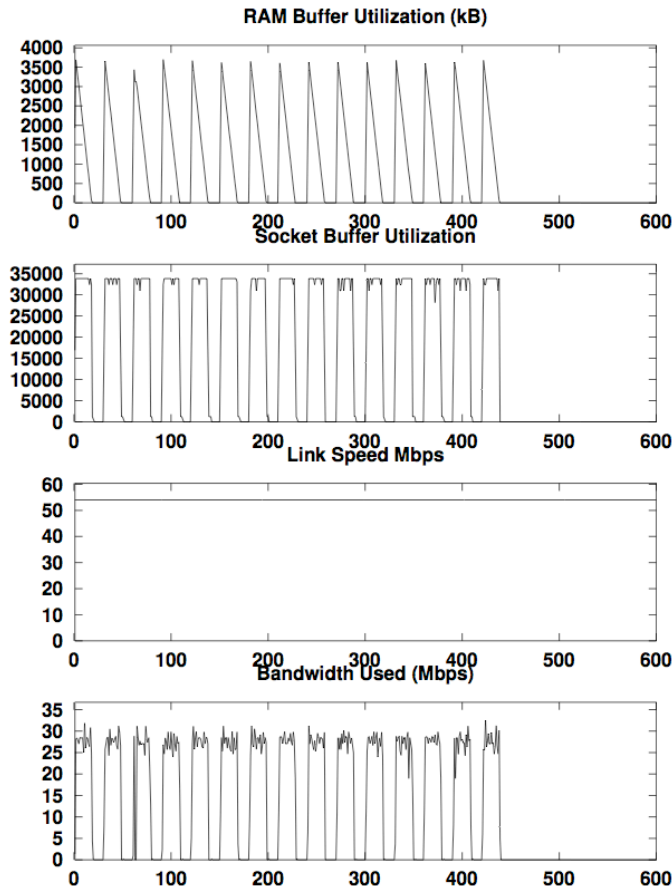

Figure 6(a): Still image capture with adequate network bandwidth

The data transfer from a location at the end of the garden is shown in Figure 6(b). Here the available bandwidth is not sufficient to transfer one complete picture before the next is

captured. The available bandwidth in this case is around 10 Mb/s on average at the start of picture capture time.

Only a portion of the picture data can be transferred before the next picture is captured after 2 seconds. The remaining data adds to the newly generated picture data and makes the ring buffer utilization to grow. When no more pictures are captured the ring buffer begins to drop in size. After a short interval all remaining buffer data is transferred over to storage. Note that this result was achieved using an 802.11g network connection. When 802.11n was used network bandwidth did not drop below 35 Mbps and the RAM buffer was able to fully off-load after each image capture.

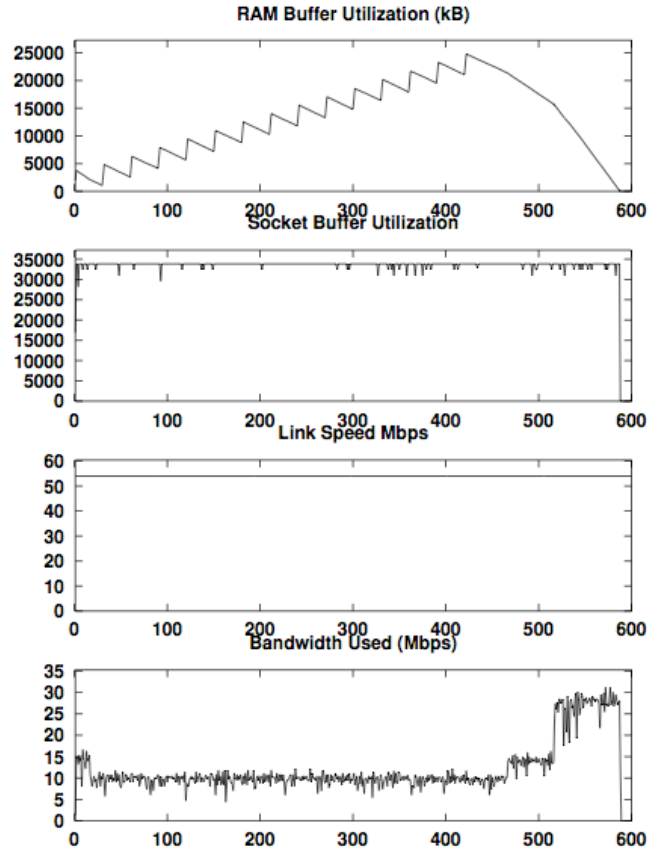

Figure 6(b): DSC image capture with insufficient network bandwidth

We conclude that the proposed solution is viable for transferring still pictures to the storage when one DSC is used in the home network. As the distance between the DSC and the AP increases, the transfer speed decreases, especially in 802.11g wireless network types. However, by employing sufficiently large ring buffers the use case does not suffer as an effect of wireless network storage utilization.

##### B. Video Transfer - Single Camera

This scenario was also tested with two configurations: in a 802.11g network and in a 802.11n network. Generally, the still pictures were transferred without problems at a rate of a 10 Mega-pixel picture each 2 seconds. This picture capture rate is perfectly acceptable for a low-end digital camera. A typical plot of the still picture capture transfer is depicted in Figure 7.

It shows 15 consecutive still pictures taken at 2 seconds intervals. All pictures were transferred at point 3 in the house.

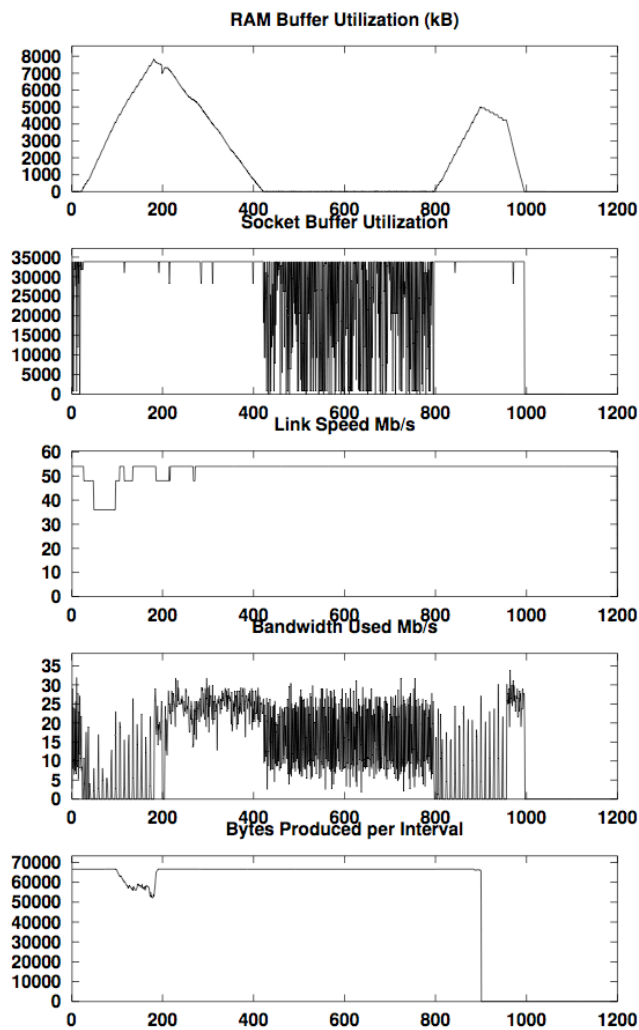

Figure 7: Digital Still Image Capture with good Network Bandwidth

For most tests there was sufficient bandwidth for a single movie camera, although with the 802.11g tests from the end of the garden the RAM buffer did increase over its initial 4 MB limit and a limit of 8 MB was subsequently used. For 802.11n tests the original 4 MB limit was adequate.

### C. Multiple-Camera Transfers

Detailed testing was also performed on various combinations of still + still, still + movie and movie + movie acquisitions. In all cases the 802.11n network was able to operate without stress throughout the test environment, including from the end of the garden (c. 50 feet from house). For 802.11g network some loading of the RAM buffer was inevitable, but if a larger RAM buffer of 32 MB was provided then the system could easily accommodate two concurrent cameras acquiring any sustained combination of still images and video clips.

## V. CONCLUSIONS & PROPOSALS FOR FUTURE WORK

For still picture capture there were no problems with two

DSC emulators capturing up to 15 pictures at a rate of a picture each 2 seconds at the same time. Both 802.11g and 802.11n wireless network configuration were able to handle these tests. In difficult network conditions the ring buffer was able to cache picture data and ensure delivery to network storage. No movie data transfer difficulty was experienced using a 802.11n wireless network. Recording two SD movies at the same time on a 802.11g wireless network storage was equally uneventful but 720p data rates were often problematic.

In the instances when the available bandwidth was reduced, the control module utility could be observed suppressing the production of new still images or reducing video bitrate. Even when the bandwidth was drastically reduced by multiple simultaneous transfer or interference, the proposed solution managed to overcome the effects of those by reducing the data production rate until the network conditions improved. This would cause some degradation of the user experience, but from our tests it was difficult to stress the system into a reduced data production mode.

The conclusion arising from this chapter data analysis is that still picture capture and SD movie recording using a custom PC storage accessed over a standard 802.11g network is possible but not recommended for HD video at 720p or higher. When an 802.11n wireless network is used then all data transfer modes can be achieved reliably, including the 720p HD movie recording data transfer.

## REFERENCES

- [1] Corcoran, P.M.; Bigioi, P.; Steinberg, E.; , "Wireless transfer of images from a digital camera to the Internet via a standard GSM mobile phone," *Consumer Electronics, IEEE Transactions on* , vol.47, no.3, pp.542-547, Aug 2001
- [2] Bigioi, P.; Ionas, A.; Susanu, G.; Corcoran, P.; , "Connectivity solution to link a Bluetooth camera to the Internet ," *Consumer Electronics, IEEE Transactions on* , vol.47, no.3, pp.294-299, Aug 2001
- [3] Bigioi, P.; Susanu, G.; Corcoran, P.; Mocanu, I.; , "Digital camera connectivity solutions using the picture transfer protocol (PTP)," *Consumer Electronics, IEEE Transactions on* , vol.48, no.3, pp. 417- 427, Aug 2002
- [4] Corcoran, P.M.; Raducan, I.; , "Practical aspects of video data transfer to network storage using 802.11 WLAN technology for low-end consumer digital cameras," *Consumer Electronics, IEEE Transactions on* , vol.49, no.4, pp. 902- 910, Nov. 2003
- [5] Bigioi, P.; Susanu, G.; Steinberg, E.; Corcoran, P.; , "PTP/IP - a new transport specification for wireless photography," *Consumer Electronics, IEEE Transactions on* , vol.51, no.1, pp. 240- 244, Feb. 2005
- [6] Corcoran, P.M.; Bigioi, P.; Steinberg, E.; Prilutsky, Y.; , "Internet enabled digital photography," *Consumer Electronics, IEEE Transactions on* , vol.45, no.3, pp.577-583, Aug 1999
- [7] Corcoran, P.M.; Steinberg, E.; , "Internet connectivity solutions for digital photography," *Consumer Electronics, IEEE Transactions on* , vol.46, no.3, pp.494-498, Aug 2000
- [8] Bigioi, P.; Raducan, I.; Steinberg, E.; Corcoran, P.; , "PTP/IP Adapter Design and Connectivity Techniques for Legacy Imaging Appliances," *Consumer Electronics, IEEE Transactions on* , vol.53, no.2, pp.405-411, May 2007